

VALUES
WE HAVE
BELIEVED
IN FOR
40 YEARS

40 YILDIR
İNANDIĞIMIZ
DEĞERLER VAR

gökçelik

**TECHNICAL
CATALOGUE
TEKNİK KATALOG**

40 YEARS

2020 YILIN ÖZÜ



EVERYWHERE THE SHELF EXISTS...

Gökçelik, since its inception in 1976, has produced shelf and display systems for the continuously growing Turkish retail and industrial sectors.

Our mission is to create storage & display systems that make our retail and industrial customers' projects succeed. To achieve this, we work to the highest standards, offer competitive prices, and deliver on time.

Our vision is of a continuously developing product by using technology, quality management and the best of human resources. But to ensure our competitiveness and market share increase, we put customer satisfaction first.

Therefore, to achieve its vision; Gökçelik's company values are: Reliability, devotion, continuous development, sensitivity, honor, justice, the power of diversity.

Today, the latest technologies employed at Gökçelik's 4 factories include: Integrated serial production. Customized & flexible production lines. Wide machine areas. Environmentally sensitive paint shops. Gökçelik, with every passing day, increases its market share in Turkey and more than 50 countries worldwide.

gokcelik.com

RAFIN OLDUĞU HER YERDE...

Raf ve sergileme üniteleri üretmek üzere 1976 yılında kurulan Gökçelik, kurulduğu günden bu yana geçen 40 yıllık zaman diliminde Türkiye perakendesinin ve endüstrisinin, geçirdiği gelişim sürecinin içinde bulunmuş ve bu sürecin bir parçası olmuştur.

Misyonu; müşterilerinin Mağaza & Market Ekipmanları ve Depolama Sistemleri alanında talep ettikleri ihtiyaçlara çözüm getirecek proje çalışmalarını yürütmek. Üzerinde ulaşılan çözümü müşteriye olması gereken kalitede, rakiplerinden daha ekonomik olarak üreterek zamanında ulaştırmak ve müşteri memnuniyetini sağlamaktır.

Gökçelik'in vizyonu ise firmanın ürün kalitesini, üretim teknolojisini, kalite yönetim sistemini ve insan kaynağını sürekli geliştirerek Pazar payını, rekabet gücünü arttırmak koşulsuz ve sürdürülebilir müşteri memnuniyeti yaratmaktır.

Firmanın bu vizyon için değerleri; Güvenilirlik, özveri, sürekli iyileştirme, duyarlılık, saygı, adalet, farklılıklardan güç almaktır.

Bu gün 4 fabrikasında ileri teknolojiye sahip seri üretim yapan entegre hatları, özel ve esnek üretime uygun geniş makine parkuru ve boya tesisleri ile çevreye duyarlı üretim yapan Gökçelik, Türkiye'de ve dünyanın 50'den fazla ülkesinde pazar payını her geçen gün artırmaya devam ediyor.



INDEX İÇİNDEKİLER

010
025

TECHNICAL
INFORMATION
TEKNİK BİLGİ

026
103

SHELVING
SYSTEMS
RAF SİSTEMLERİ

104
123

BAKERIES
UNLU MAMÜLLER

124
139

FRUIT &
VEGETABLE UNIT
MEYVE VE SEBZE
REYONU

140
165

ELECTRONIC &
MUSIC & BOOK
ELEKTRONİK &
MÜZİK & KİTAP

166
173

TURNSTILES &
BARRIERS
TURNİKELER &
BARİYERLER

174
203

CHECK-OUT
KASAALTI

204
235

ACCESSORIES
AKSESUARLAR

236
319

STORE SYSTEMS (Textile Stores,
Shoe Stores, Home Appliance Stores etc.)
MAĞAZA SİSTEMLERİ (Giyim Mağazaları,
Ayakkabı Mağazaları, Ev Eşyası Mağazaları vs.)



**TECHNICAL
INFORMATION**
TEKNİK BİLGİ



**TECHNICAL
INFORMATION**
TEKNİK BİLGİ

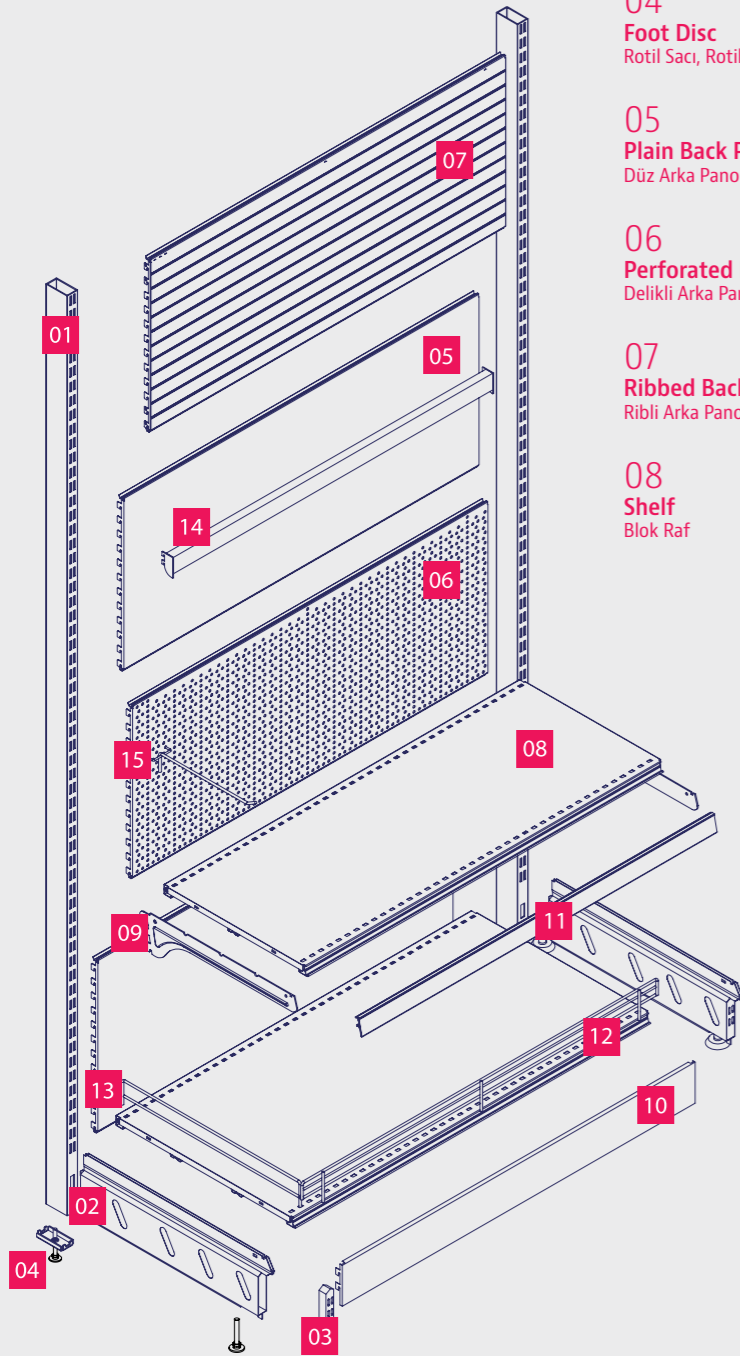

01
Upright Box Profile
Dikme Kutu Profil

02
Base Leg
Geçme Ayak

03
Front Plastic For Base Leg
Geçme Ayak Ön Plastiği

04
Foot Disc
Rotil Sacı, Rotil Takımı

05
Plain Back Panel
Düz Arka Pano

06
Perforated Back Panel
Delikli Arka Pano

07
Ribbed Back Panel
Ribli Arka Pano

08
Shelf
Blok Raf

09
Bracket
Konsol

10
Front Panel
Alt Ön Panel

11
Label Holder
Raf Etiketliği

12
Front Grill H: 40 mm
Ön Tel H: 40 mm

13
Separation Grill H: 40 mm
Yan Tel H: 40 mm

14
Rear Bar
Profile Geçme Askı Tutucu

15
**Wire Hook For
Perforated Back Panel**
Delikli Saca Geçme Düz
Spot Tel



**TECHNICAL
INFORMATION**
TEKNİK BİLGİ

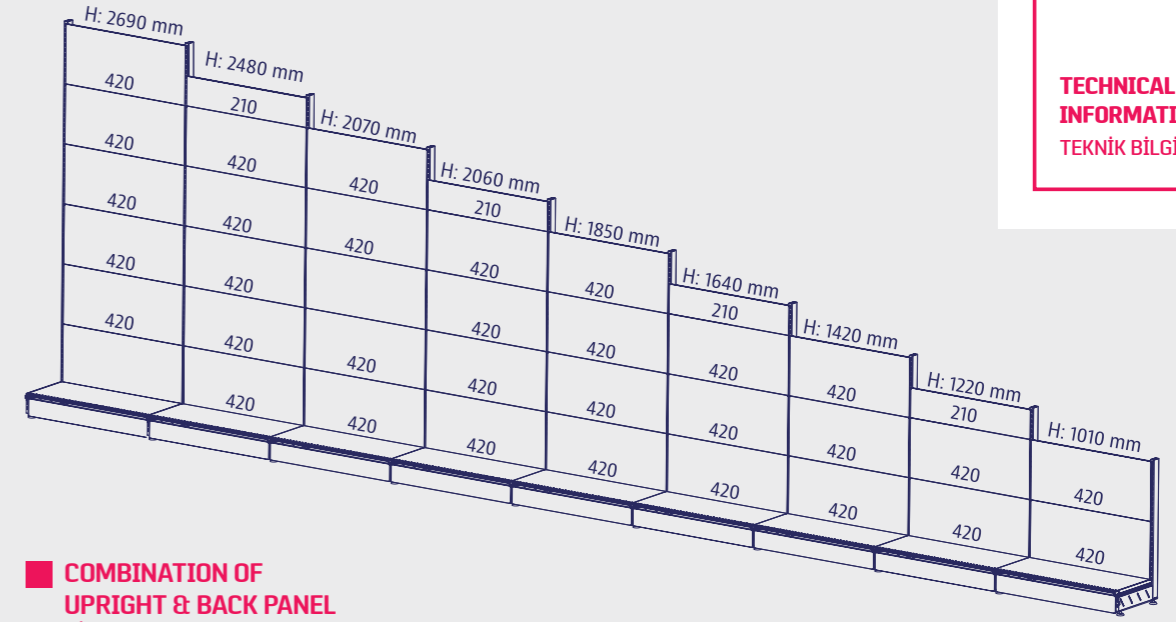

**COMBINATION OF
UPRIGHT & BACK PANEL**
DİKME & ARKA SAC
KOMBİNASYONU

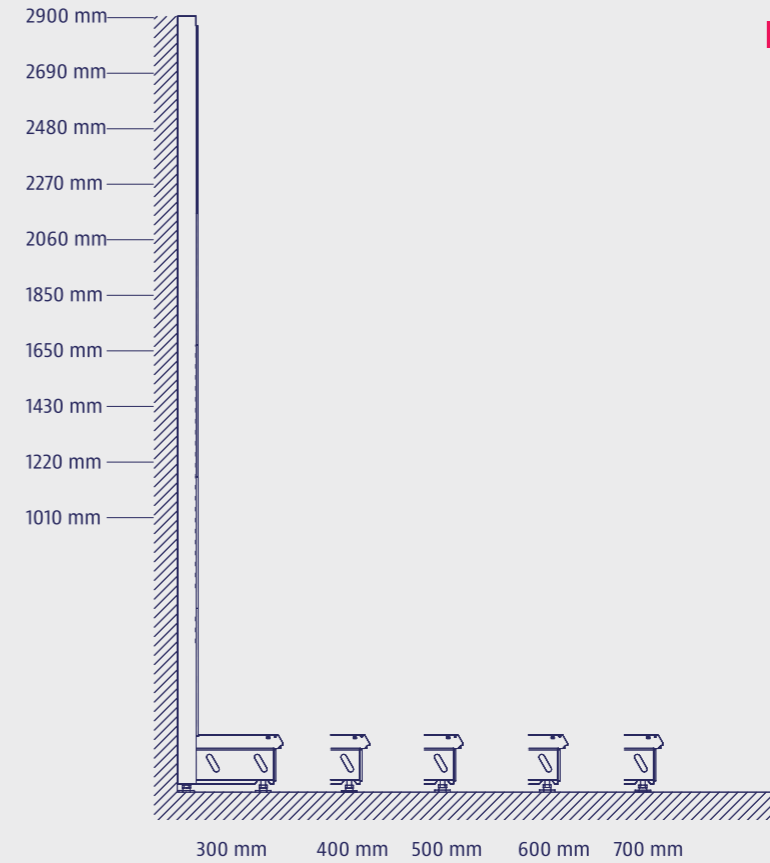

**COMBINATION OF UPRIGHT
& BASE LEG** DİKME & GEÇME
AYAK KOMBİNASYONU



TECHNICAL
INFORMATION
TEKNİK BİLGİ

DOUBLE HOLE SYSTEM
ÇİFT DELİK SİSTEM

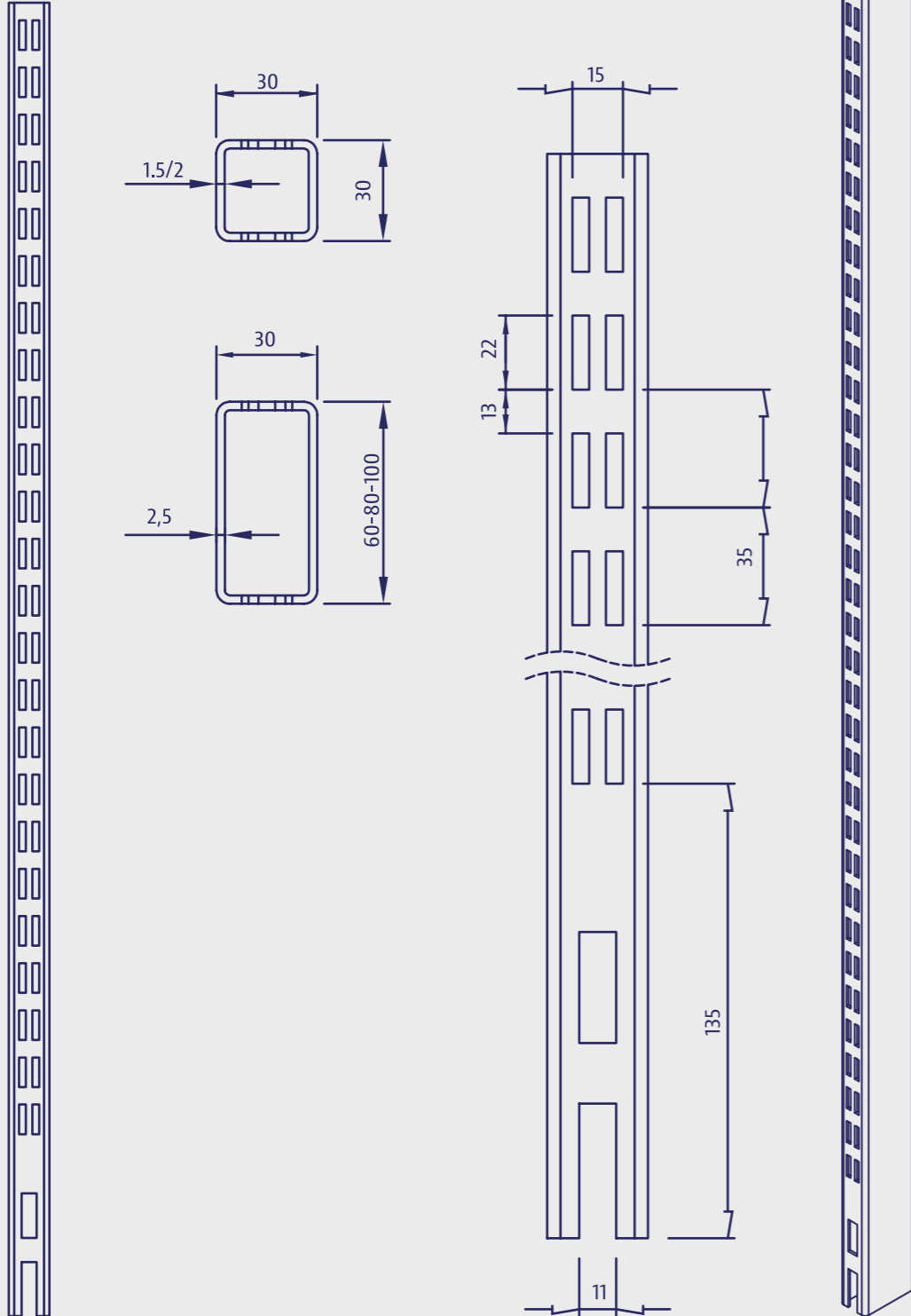

TECHNICAL
INFORMATION
TEKNİK BİLGİ

SHELF DETAIL
RAF DETAYI

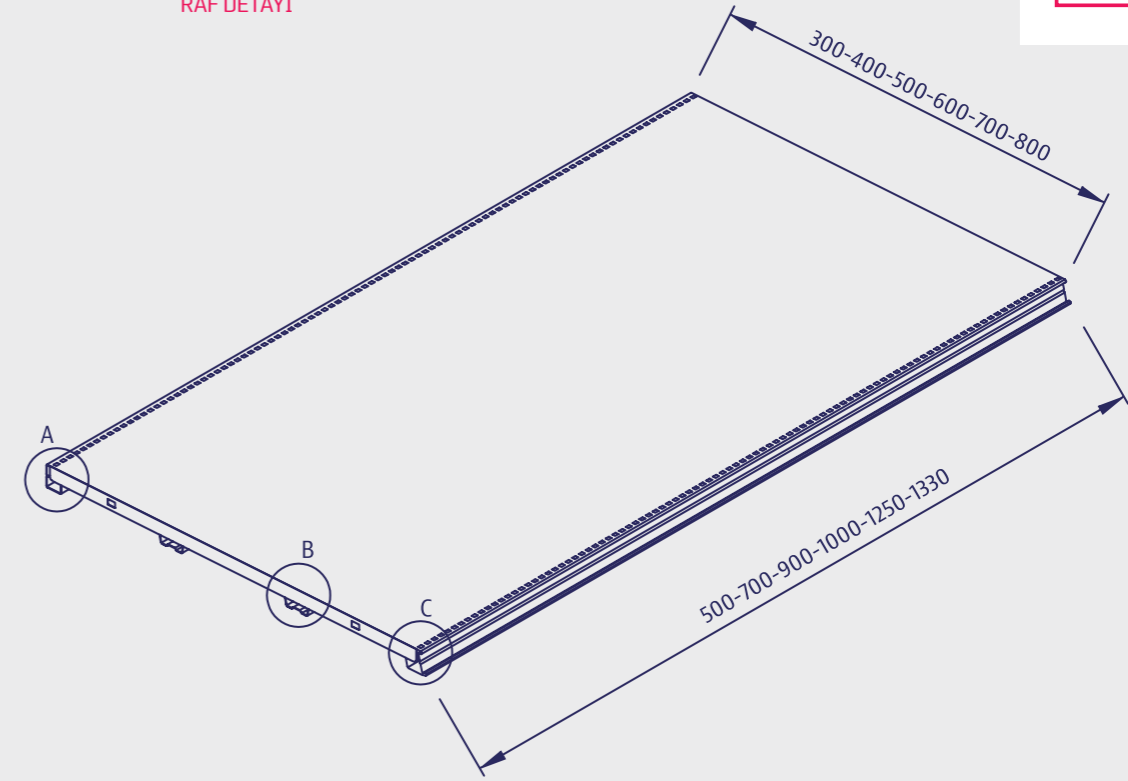

A

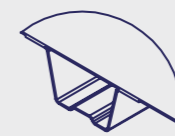

B



C



**TECHNICAL
INFORMATION**
TEKNİK BİLGİ

BRACKET WITH 3 HOLDERS
KONSOL 3 TIRNAKLI



300-400 Bracket With 3 Holders
300-400 3 Tirnaklı Konsol

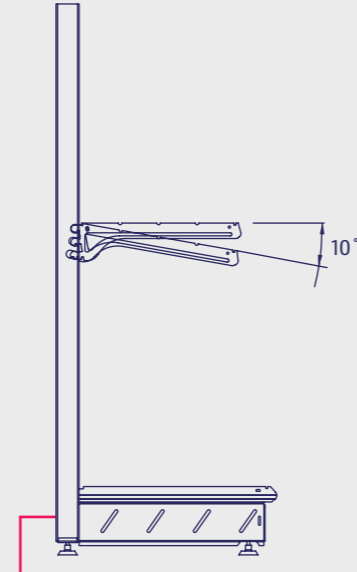

Bracket Angle Position
Konsol Açılı Duruş Şekli

BRACKET WITH 4 HOLDERS
KONSOL 4 TIRNAKLI

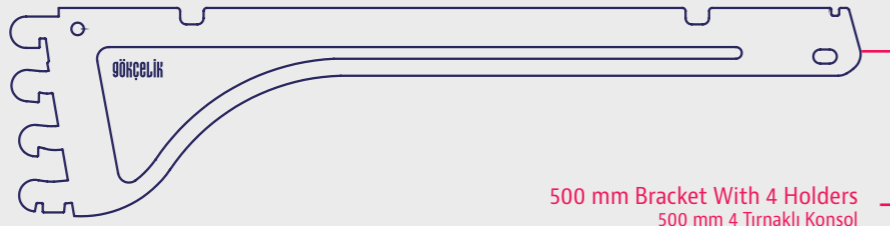

500 mm Bracket With 4 Holders
500 mm 4 Tirnaklı Konsol

BRACKET WITH 4 HOLDERS
KONSOL 4 TIRNAKLI

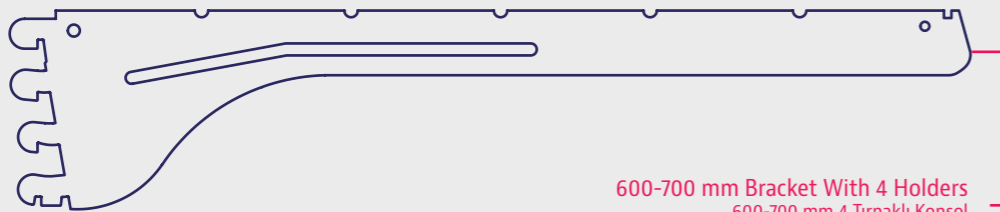

600-700 mm Bracket With 4 Holders
600-700 mm 4 Tirnaklı Konsol



**TECHNICAL
INFORMATION**
TEKNİK BİLGİ

PLAIN BACK PANEL
DÜZ ARKA PANO



Plain Back Panel
210 mm
Düz Arka Pano
210 mm

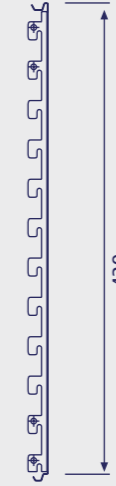

Plain Back Panel
420 mm
Düz Arka Pano
420 mm

RIBBED BACK PANEL
RİBLİ ARKA PANO

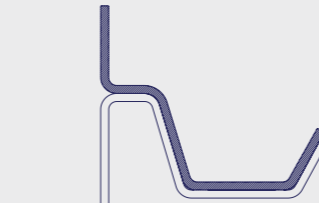

Ribbed Back Panel 210 mm
Ribli Arka Pano 210 mm

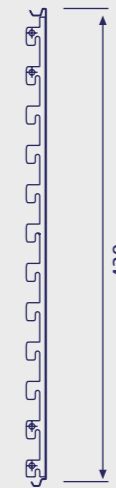

Ribbed Back Panel 420 mm
Ribli Arka Pano 420 mm



**TECHNICAL
INFORMATION**
TEKNİK BİLGİ

PERFORATED BACK PANEL
EURO DELİKLİ ARKA PANO

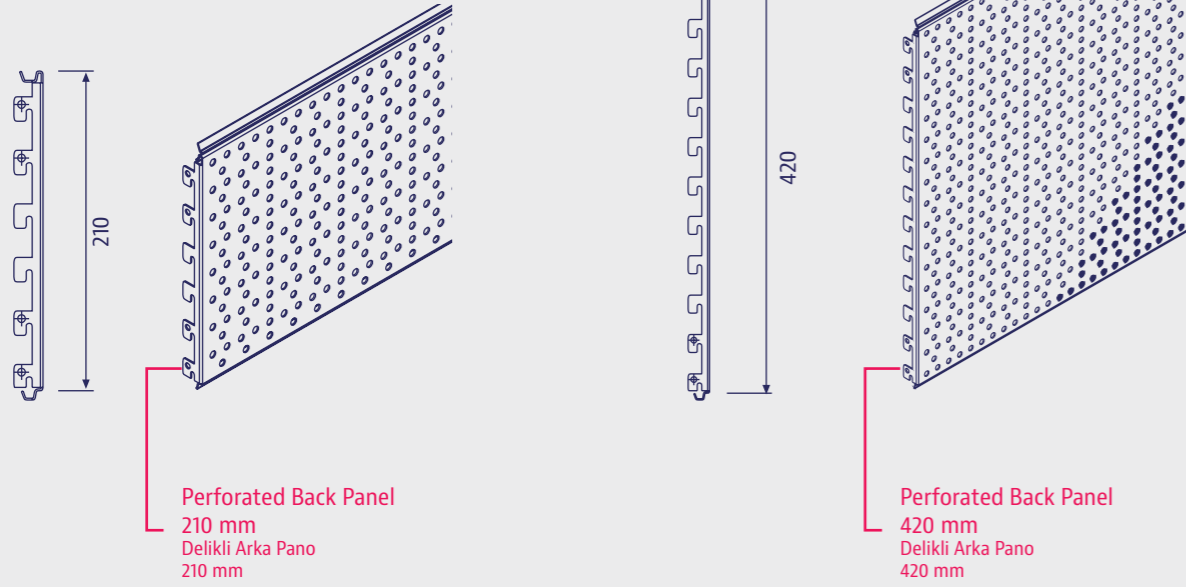

Perforated Back Panel
210 mm
Delikli Arka Pano
210 mm

Perforated Back Panel
420 mm
Delikli Arka Pano
420 mm

EURO HOLE SYSTEM
EURO DELİK

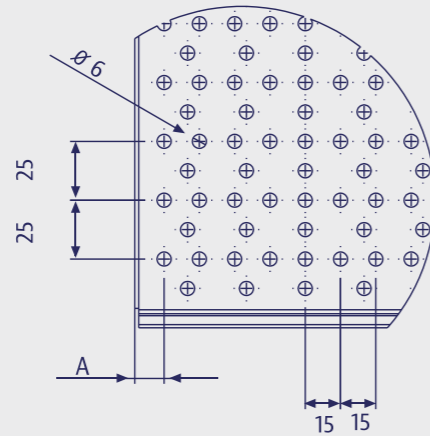

L	"A"
1320 mm	15
1240 mm	12.5
990 mm	15
974 mm	14.5
890 mm	10
830 mm	10
790 mm	12.5
690 mm	15
590 mm	10
490 mm	12.5



Back Panel
Locking System
Arka Pano
Kilitleme Sistemi



**TECHNICAL
INFORMATION**
TEKNİK BİLGİ

LOADING CAPACITY OF UNITS
ÜNİTELERİN TAŞIMA KAPASİTELERİ

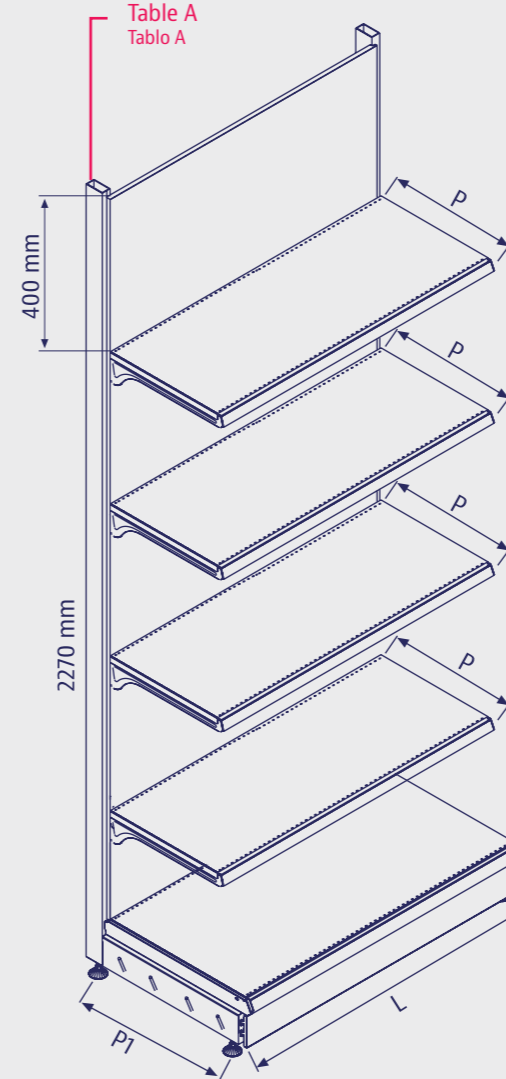

- Loading has to be from base shelf to upside.
- Spaces between shelves have to be equal vertically.
- Top shelf has to be 400 mm lower than top of the upright.
- For double side gondola units loading has to be equal on both sides for balance. In that case total loading capacity of gondolas is double of wall units.
- For gondola groups which is higher than 1650 mm, gondola head has to be fixed to gondola group.
- Wall units height is 2060 mm and more has to be fixed to the wall. (Attention please! Wall and fixing element have to be suitable for this process)
- Loading capacity can be increased by wall fixing. (Attention please! Wall and fixing element have to be suitable for this process)
- Loads must be positioned well-arranged and homogen on the shelf.
- Please contact with us for your specific loading needs.
- Shelving stands must be stacked with loads diminishing towards the top shelf.
- Regulation of foot discs under the base leg and uprights has to be checked depending on floor conditions.
- If they are not in balance, foot screw has to be adjusted. (PS. This adjustment has to be before loading of shelves)

- Yüklemeye baza rafından başlanmalıdır.
- Raf aralıkları mümkün olduğu kadar eşit olmalıdır.
- En üst raf dikmenin üst noktasından 400 mm aşağıda olmalıdır.
- Çift yönlü ünitelerde ünitenin her iki yüzü de eşit yüklenmelidir. Bu durumda çift yönlü ünitelerin toplam taşıma kapasitesi, duvar reyonlarının iki katıdır.
- 1650 mm'den yüksek orta reyonlarda, gondol başı orta reyonlara sabitlenmelidir.
- 2060 mm ve daha yüksek dikme kullanılan ünitelerde dikmeler mutlaka duvara sabitlenmelidir. (Lütfen dikkat! Duvar ve bağlantı elemanı bu işlem için uygun olmalıdır.)
- Taşıma kapasiteleri duvar bağlantıları ile artırılabilir. (Lütfen dikkat! Duvar ve bağlantı elemanı bu işlem için uygun olmalıdır.)
- Yükler raf üzerinde düzgün yayılı ve homojen olarak konulmalıdır.
- Özel yüklemeler için lütfen bizimle temasa geçiniz.
- Üniteler üst rafa doğru çıktıkça yük azalacak şekilde yüklenmelidir.
- Baza ve dikmedeki rotill vidalarının zemine göre uygun ayarda olduğu kontrol edilmelidir.
- Değillerse ünite dengede olacak şekilde rotill vidaları ayarlanmalıdır. (Bu işlem raflar yüklenmeden yapılmalıdır.)

30x60 / Cross Section for Upright
Dikme Kesit

P : 300 mm
P1: 300 mm (Base / Baza)

L	Loading Capacity Taşıma Kapasitesi
700	340 kg
1000	300 kg
1250	260 kg
1300	260 kg

P : 400 mm
P1: 400 mm (Base / Baza)

L	Loading Capacity Taşıma Kapasitesi
700	300 kg
1000	260 kg
1250	240 kg
1300	230 kg

P : 500 mm
P1: 500 mm (Base / Baza)

L	Loading Capacity Taşıma Kapasitesi
700	250 kg
1000	240 kg
1250	230 kg
1300	220 kg



**TECHNICAL
INFORMATION**
TEKNİK BİLGİ

LOADING CAPACITY OF UNITS
ÜNİTELERİN TAŞIMA KAPASİTELERİ

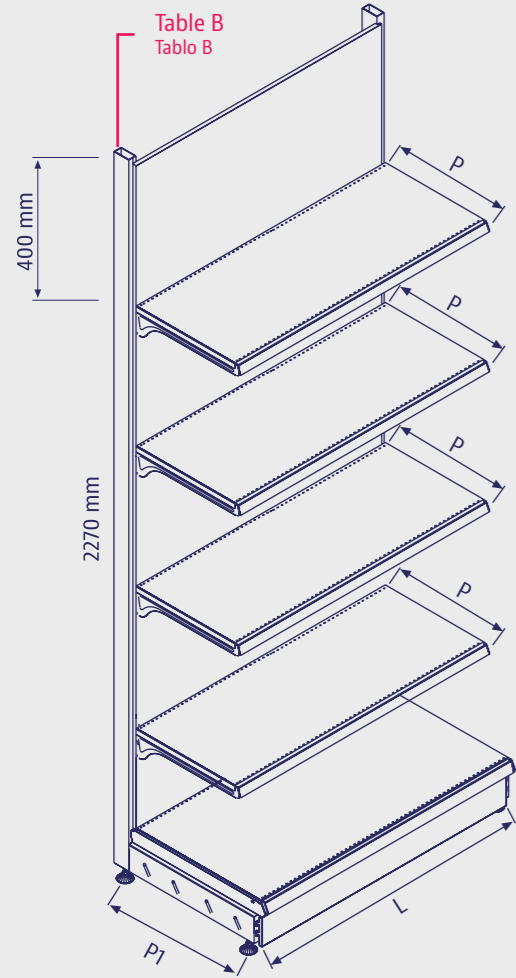

- Loading has to be from base shelf to upside.
- Spaces between shelves have to be equal vertically.
- Top shelf has to be 400 mm lower than top of the upright.
- For double side gondola units loading has to be equal on both sides for balance. In that case total loading capacity of gondolas is double of wall units.
- For gondola groups which is higher than 1650 mm, gondola head has to be fixed to gondola group.
- Wall units height is 2060 mm and more has to be fixed to the wall. (Attention please! Wall and fixing element have to be suitable for this process)
- Loading capacity can be increased by wall fixing. (Attention please! Wall and fixing element have to be suitable for this process)
- Loads must be positioned well-arranged and homogen on the shelf.
- Please contact with us for your specific loading needs.
- Shelving stands must be stacked with loads diminishing towards the top shelf.
- Regulation of foot discs under the base leg and uprights has to be checked depending on floor conditions.
- If they are not in balance, foot screw has to be adjusted. (PS. This adjustment has to be before loading of shelves)

- Yüklemeye baza rafından başlanmalıdır.
- Raf aralıkları mümkün olduğu kadar eşit olmalıdır.
- En üst raf dikmenin üst noktasından 400 mm aşağıda olmalıdır.
- Çift yönlü ünitelerde ünitenin her iki yüzü de eşit yüklenmelidir. Bu durumda çift yönlü ünitelerin toplam taşıma kapasitesi, duvar reyonlarının iki katıdır.
- 1650 mm'den yüksek orta reyonlarda, gondol başı orta reyonlara sabitlenmelidir.
- 2060 mm ve daha yüksek dikme kullanılan ünitelerde dikmeler mutlaka duvara sabitlenmelidir. (Lütfen dikkat! Duvar ve bağlantı elemanı bu işlem için uygun olmalıdır.)
- Taşıma kapasiteleri duvar bağlantıları ile artırılabilir. (Lütfen dikkat! Duvar ve bağlantı elemanı bu işlem için uygun olmalıdır.)
- Yükler raf üzerinde düzgün yayılı ve homojen olarak konulmalıdır.
- Özel yüklemeler için lütfen bizimle temasa geçiniz.
- Üniteler üst rafa doğru çıktıkça yük azalacak şekilde yüklenmelidir.
- Baza ve dikmedeki rotül vidalarının zemine göre uygun ayarında olduğu kontrol edilmelidir.
- Değişirse ünite dengede olacak şekilde rotül vidaları ayarlanmalıdır. (Bu işlem raflar yüklenmeden yapılmalıdır.)

30x80 / Cross Section for Upright
Dikme Kesit

P : 500 mm
P1: 500 mm (Base / Baza)

L	Loading Capacity Taşıma Kapasitesi
700	450 kg
1000	440 kg
1250	430 kg
1330	420 kg

P : 600 mm
P1: 600 mm (Base / Baza)

L	Loading Capacity Taşıma Kapasitesi
700	430 kg
1000	430 kg
1250	420 kg
1330	410 kg

30x100 / Cross Section for Upright
Dikme Kesit

L	Loading Capacity Taşıma Kapasitesi
700	380 kg
1000	380 kg
1250	370 kg
1330	360 kg



**TECHNICAL
INFORMATION**
TEKNİK BİLGİ

LOADING CAPACITY FOR SHELF
RAF TAŞIMA KAPASİTELERİ



LENGTH	P: 300 mm	P: 400 mm
700	85 kg	100 kg
900	85 kg	100 kg
1000	85 kg	100 kg
1250	85 kg	100 kg
1330	85 kg	100 kg

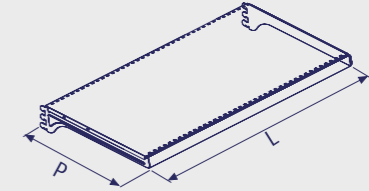

LENGTH	P: 500 mm	P: 600 mm
700	150 kg	120 kg
900	150 kg	120 kg
1000	150 kg	120 kg
1250	150 kg	120 kg
1330	150 kg	120 kg

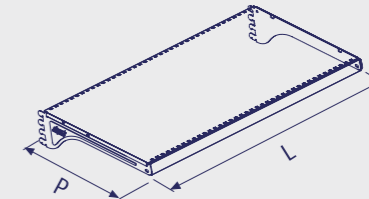

LENGTH	P: 300 mm	P: 400 mm	P: 500 mm	P: 600 mm	P: 700 mm
700	200 kg	220 kg	250 kg	250 kg	250 kg
900	200 kg	220 kg	250 kg	250 kg	250 kg
1000	200 kg	220 kg	250 kg	250 kg	250 kg
1250	200 kg	220 kg	250 kg	250 kg	250 kg
1330	200 kg	220 kg	250 kg	250 kg	250 kg

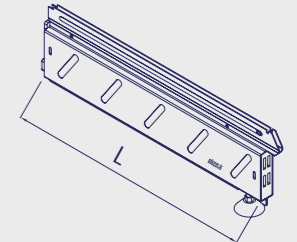

- Determined values at below mean capacity of one single shelf with two brackets independently for loading capacity of units, you could look Table A and Table B.
- Determined loads presuppose equal distribution over the shelf and positioned well arranged.
- Please contact with us for your specific loading needs.

- Yukarıda verilen değerler, bir tek rafın iki yanak ile bağımsız olarak taşıyabileceği yükü gösterir. Ünitelerinin genel taşıma kapasiteleri için lütfen Tablo A ve Tablo B'ye bakınız.
- Bildirilen yükler rafa eşit dağılmış ve düzgün yüklenmiş sayılır.
- Özel yüklemeler için lütfen bizimle temasa geçiniz.



**TECHNICAL
INFORMATION**
TEKNİK BİLGİ

COLOURS
RENKLER

- Products are coated in following standard colours
- The colours depicted on the following chart are for guidance only. The finished colours may appear slightly different. Please use the official RAL catalogue for most accurate colours.
- For different colours, please contact with us.

- Ürünler aşağıdaki standart renklere boyanmaktadır.
- Bu tabloda gösterilen renkler sadece fikir verme amaçlıdır. Gerçek renkler farklılık gösterebilir. En doğru renk için resmi RAL kataloğunu kullanın.
- Farklı renkler için lütfen bizimle irtibata geçiniz.

Ral 9010



Main Color
Ana Renk

Ral 9001		Ral 7035	
Ral 9010		Ral 7040	
Ral 9005		Ral 7024	
Ral 9006			
Ral 3020		Ral 2004	
Ral 3002		Ral 2008	
Ral 4003		Ral 1018	
Ral 4008		Ral 1023	
Ral 5005		Ral 6018	
Ral 5010		Ral 6024	
Ral 5018		Ral 6027	
		Ral 6032	



**TECHNICAL
INFORMATION**
TEKNİK BİLGİ

SAMPLE LAYOUT
ÖRNEK YERLEŞİM PLANI

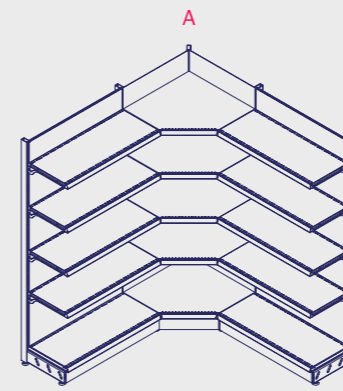
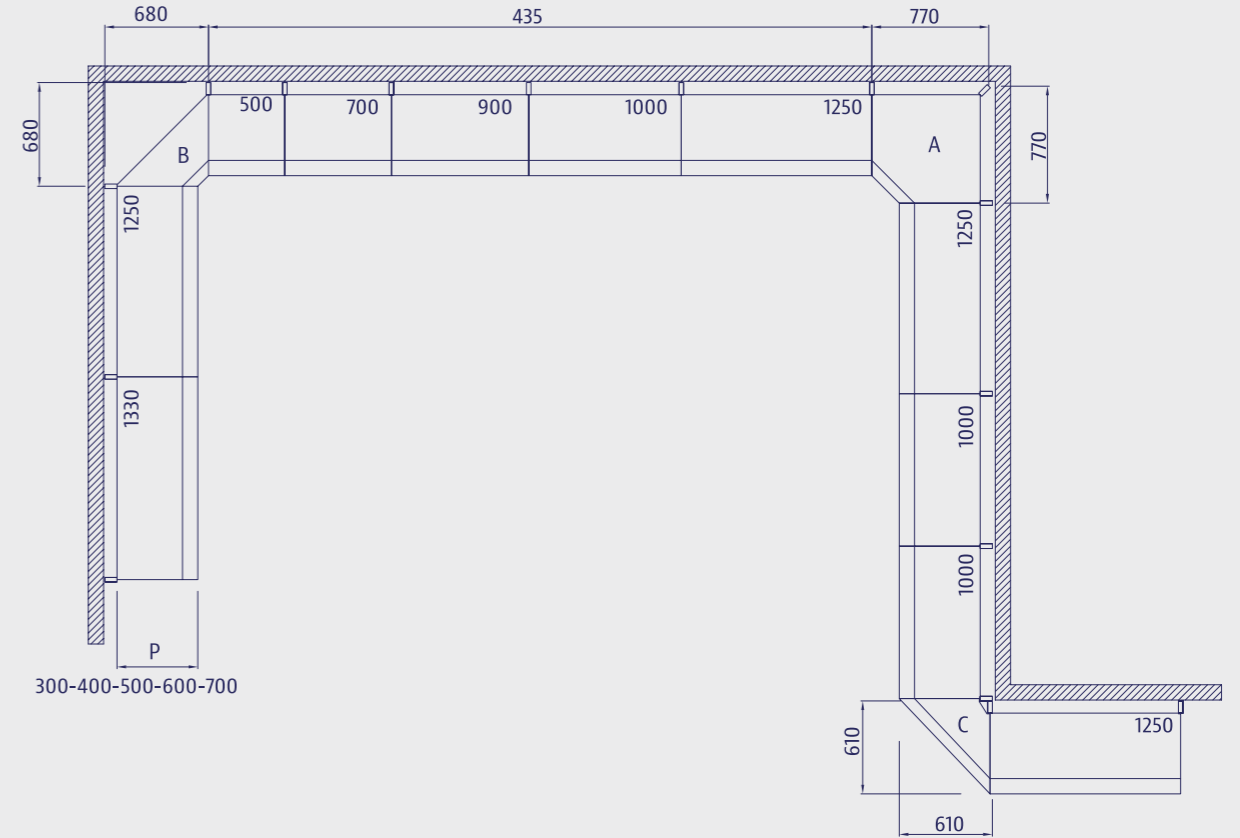

Internal Corner 90°
90° İç Köşe

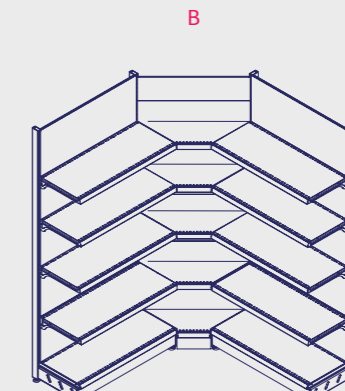

Internal Corner
İç Köşe

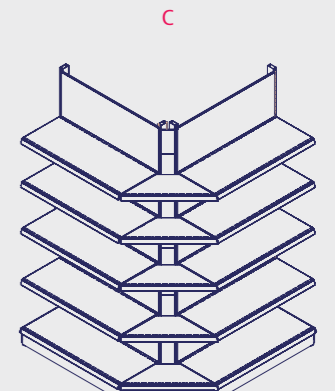

External Corner
Dış Köşe



**TECHNICAL
INFORMATION**
TEKNİK BİLGİ

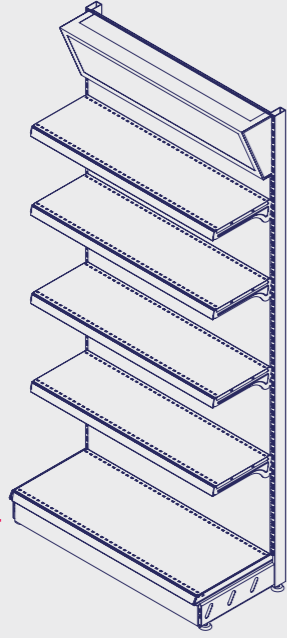

Wall Unit With Header / Şapkalı Duvar Ünitesi
H: 2270 mm L: 1000 mm
400B / 300 / 300 / 300 / 300 / C

SAMPLE COMBINATIONS
ÖRNEK KOMBİNASYONLAR

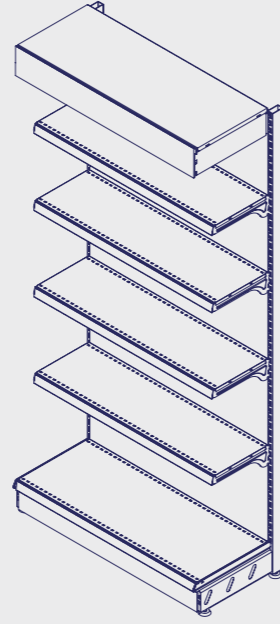

Wall Unit With Header / Şapkalı Duvar Ünitesi
H: 2270 mm L: 1000 mm
400B / 300 / 300 / 300 / 300 / C

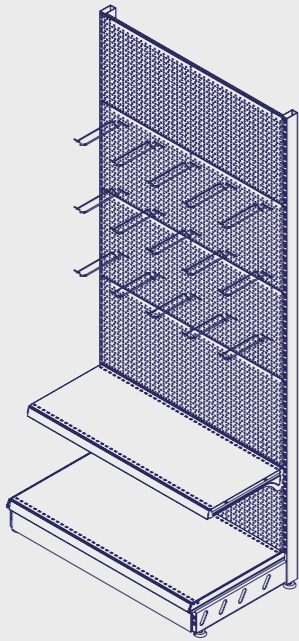

Wall Unit / Duvar Ünitesi
H: 2270 mm L: 1000 mm
500B / 400
With perforated back panel & wire hooks
Delikli Arka Panel

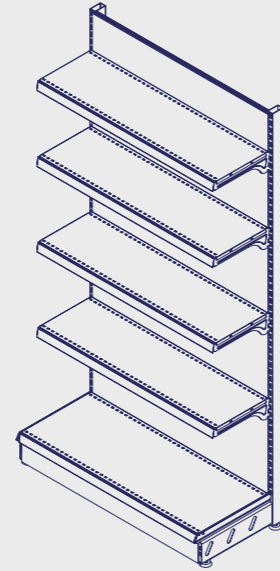

Wall Unit / Duvar Ünitesi
H: 2060 mm L: 1000 mm
400B / 300 / 300 / 300 / 300



**TECHNICAL
INFORMATION**
TEKNİK BİLGİ

SAMPLE COMBINATIONS
ÖRNEK KOMBİNASYONLAR

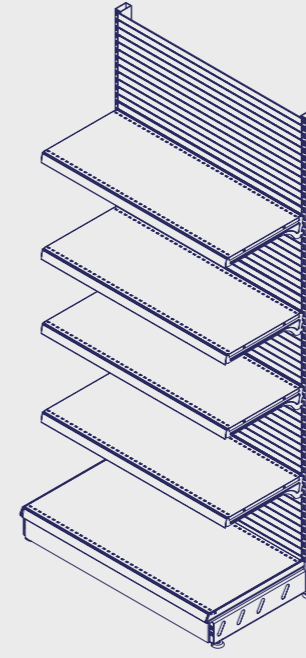

Wall Unit / Duvar Ünitesi
H: 2270 mm L: 1000 mm
500B / 400 / 400 / 400 / 400

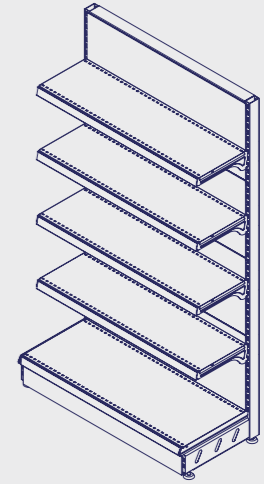

Gondola Head Unit / Gondol Başı
H: 1850 mm L: 1000 mm
400B / 300 / 300 / 300 / 300

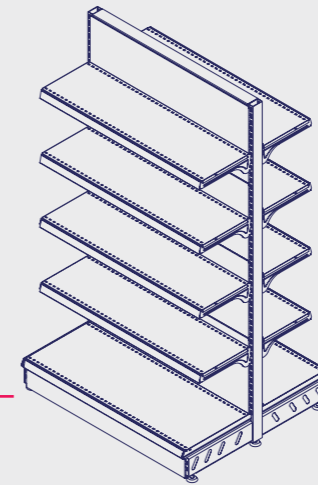

Gondola Unit / Çift Yönlü Orta Reyon
H: 1850 mm L: 1000 mm
500B / 400 / 400 / 400 / 400 x 2

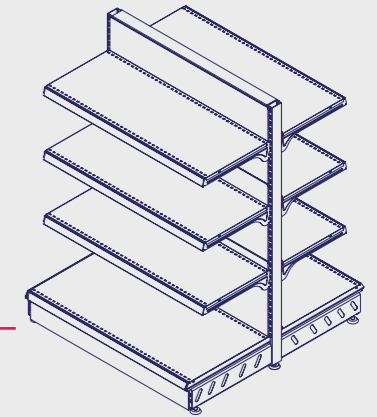

Gondola Unit / Çift Yönlü Orta Reyon
H: 1430 mm L: 1000 mm
500B / 400 / 400 / 400 x 2



**SHELVING
SYSTEMS**
RAF SİSTEMLERİ



**SHELVING
SYSTEMS
RAF SİSTEMLERİ**

**UPRIGHT (30x30 BOX PROFILE)
DİKME 30x30**

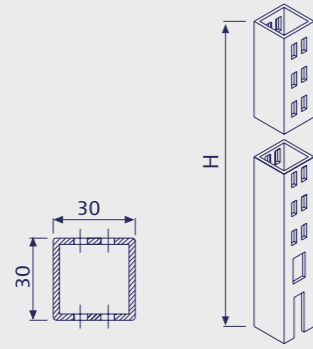

Code / Kod	P	H	L	Description / Açıklama
1A0000001B		1010		
1A0000002B		1220		
1A0000003B		1430		
1A0000004B		1640		
1A0000005B		1850		
1A0000006B		2060		
1A0000007B		2270		
1A0000008B		2480		
1A0000009B		2690		
1A0000010B		2900		



**SHELVING
SYSTEMS
RAF SİSTEMLERİ**

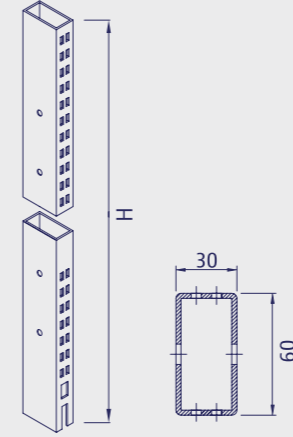

Code / Kod	P	H	L	Description / Açıklama
1B00000031B		1010*		* For 2 Fixing Beam
1B00000032B		1220*		** For 3 Fixing Beam
1B00000033B		1430*		
1B00000034B		1640*		* 2 ara bağlantı
1B00000035B		1850*		** 3 ara bağlantı
1B00000036B		2060*		
1B00000037B		2270*		
1B00000038B		2480**		
1B00000039B		2690**		
1B00000040B		2900**		

**UPRIGHT 30X60 WITH
FIXING BEAM HOLES
DİKME 30X60 ARA BAĞLANTI DELİKLİ**

**UPRIGHT (30x60 BOX PROFILE)
DİKME 30X60**

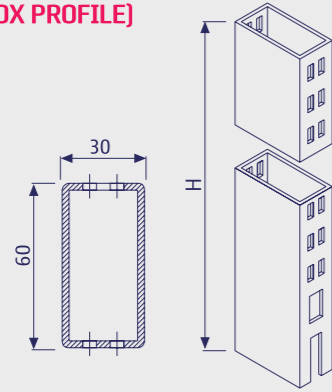

Code / Kod	P	H	L	Description / Açıklama
1B0000001B		1010		
1B0000002B		1220		
1B0000003B		1430		
1B0000004B		1640		
1B0000005B		1850		
1B0000006B		2060		
1B0000007B		2270		
1B0000008B		2480		
1B0000009B		2690		
1B0000010B		2900		

**UPRIGHT 30X80 WITH
FIXING BEAM HOLES
DİKME 30X80 ARA
BAĞLANTI DELİKLİ**

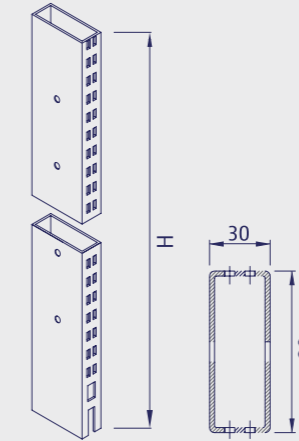

Code / Kod	P	H	L	Description / Açıklama
1C00000031B		1010*		* For 2 Fixing Beam
1C00000032B		1220*		** For 3 Fixing Beam
1C00000033B		1430*		
1C00000034B		1640*		* 2 ara bağlantı
1C00000035B		1850*		** 3 ara bağlantı
1C00000036B		2060*		
1C00000037B		2270*		
1C00000038B		2480**		
1C00000039B		2690**		
1C00000040B		2900**		

**UPRIGHT (30x80 BOX PROFILE)
DİKME 30X80**

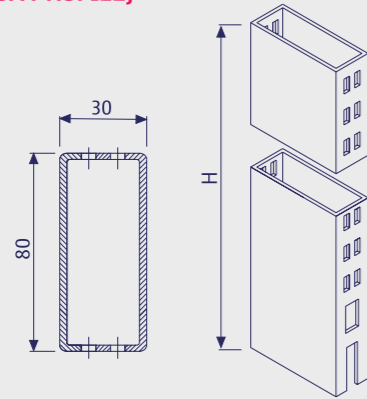

Code / Kod	P	H	L	Description / Açıklama
1C0000001B		1010		
1C0000002B		1220		
1C0000003B		1430		
1C0000004B		1640		
1C0000005B		1850		
1C0000006B		2060		
1C0000007B		2270		
1C0000008B		2480		
1C0000009B		2690		
1C0000010B		2900		

**UPRIGHT 30X100 WITH
FIXING BEAM HOLES
DİKME 30X100 ARA
BAĞLANTI DELİKLİ**

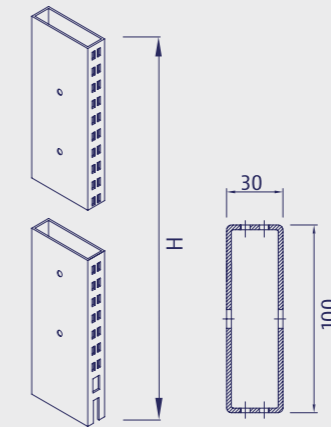

Code / Kod	P	H	L	Description / Açıklama
1D00000031B		1010*		* For 2 Fixing Beam
1D00000032B		1220*		** For 3 Fixing Beam
1D00000033B		1430*		
1D00000034B		1640*		* 2 ara bağlantı
1D00000035B		1850*		** 3 ara bağlantı
1D00000036B		2060*		
1D00000037B		2270*		
1D00000038B		2480**		
1D00000039B		2690**		
1D00000040B		2900**		

**UPRIGHT (30x100 BOX PROFILE)
DİKME 30X100**

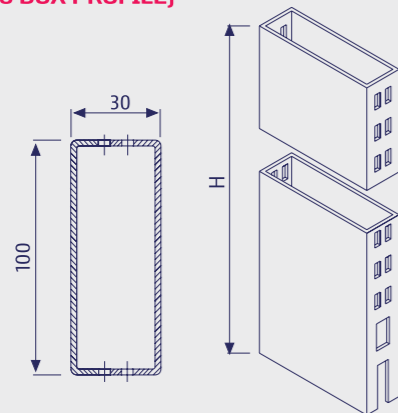

Code / Kod	P	H	L	Description / Açıklama
1D0000001B		1010		
1D0000002B		1220		
1D0000003B		1430		
1D0000004B		1640		
1D0000005B		1850		
1D0000006B		2060		
1D0000007B		2270		
1D0000008B		2480		
1D0000009B		2690		
1D0000010B		2900		

**UPRIGHT EXTENSION
DİKME UZATMA**



Code / Kod	P	H	L	Description / Açıklama
1B00000042B	30x60	210		
1B00000041B	30x60	420		
1C00000042B	30x80	210		
1C00000041B	30x80	420		
1D00000042B	30x100	210		
1D00000041B	30x100	420		



**SHELVING
SYSTEMS**
RAF SİSTEMLERİ

FIXING BEAM WITH BOLT HOLE SET
ARA BAĞLANTI TAKIMI CİVATA DELİKLİ

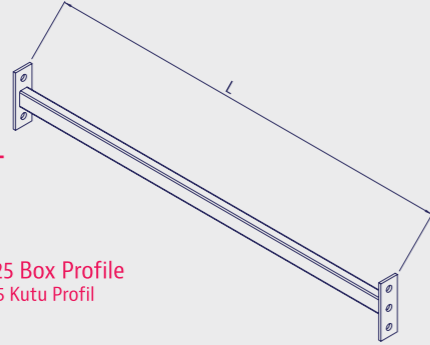

15x25 Box Profile
15x25 Kutu Profil

Code / Kod	P	H	L	Description / Açıklama
12G0000021T			500	
12G0000022T			600	
12G0000023T			700	
12G0000024T			800	
12G0000025T			900	
12G0000026T			1000	
12G0000027T			1100	
12G0000028T			1200	
12G0000029T			1250	
12G0000030T			1330	



**SHELVING
SYSTEMS**
RAF SİSTEMLERİ

PLASTIC PLUG FOR BASE LEG
GEÇME AYAK ÖN PLASTİK

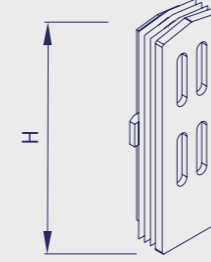

Code / Kod	P	H	L	Description / Açıklama
93000000030		85		Only black colour Siyah renk

BASE LEG
GEÇME AYAK

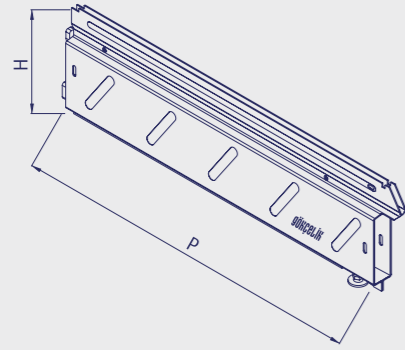

Code / Kod	P	H	L	Description / Açıklama
2A00000003B	200	135		* P: 600 P: 700 and
2A00000005B	300	135		P: 800 base legs will be
2A00000006B	400	135		welded to upright.
2A00000007B	500	135		* P: 600 P: 700 ve
2A00000008B	600*	135		P: 800 geçme ayaklar
2A00000009B	700*	135		dikmeye kaynaklı
2A00000010B	800*	135		olacaktır.

PLASTIC PLUG FOR UPRIGHT
DİKME KAPAĞI

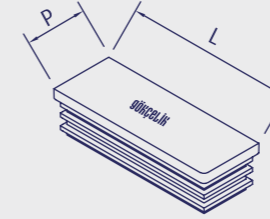

Code / Kod	P	H	L	Description / Açıklama
930000000705	30	30		
93000000024	30	60		
93000000022	30	80		
930000000706	30	100		

FOOT SCREW
ROTİL CİVATASI

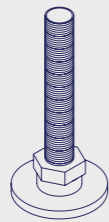

Code / Kod	P	H	L	Description / Açıklama
93000000014				

FOOT DISC
ROTİL SACI

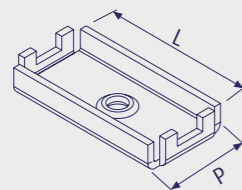

Code / Kod	P	H	L	Description / Açıklama
19D0000009G	37	31		
19D0000001G	37	61		
19D0000002G	37	81		
19D0000003G	37	101		

FIXING PART
DUVARA BAĞLANTI APARATI

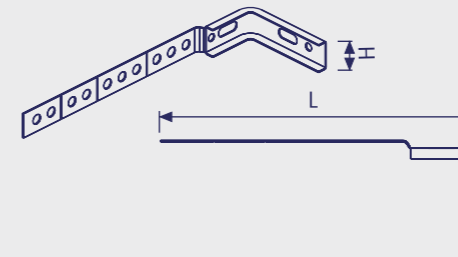

Code / Kod	P	H	L	Description / Açıklama
93000000014		42	220	



**SHELVING
SYSTEMS
RAF SİSTEMLERİ**

**PLAIN BACK PANEL
DÜZ ARKA PANO**

Code / Kod	P	H	L	Description / Açıklama
4A0000001B	420	500		
4A0000003B	420	700		
4A0000005B	420	900		
4A0000006B	420	1000		
4A0000008B	420	1250		
4A0000009B	420	1330		

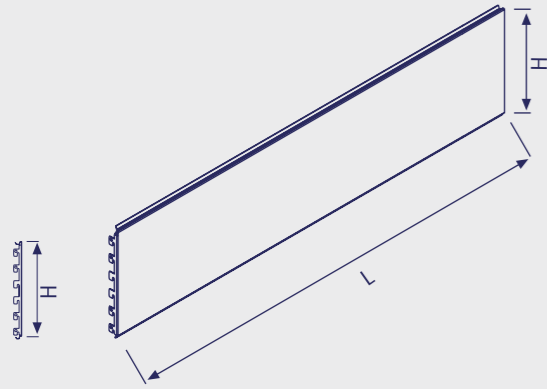
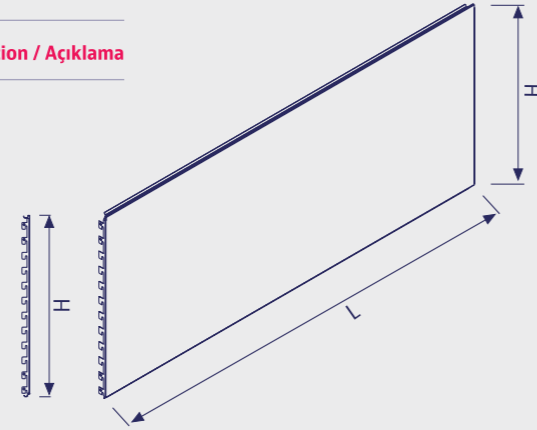

Code / Kod	P	H	L	Description / Açıklama
4A0000010B	210	500		
4A0000012B	210	700		
4A0000014B	210	900		
4A0000015B	210	1000		
4A0000017B	210	1250		
4A0000018B	210	1330		

**PERFORATED BACK PANEL
DELİKLİ ARKA PANO**

Code / Kod	P	H	L	Description / Açıklama
4C0000001B	420	500		
4C0000003B	420	700		
4C0000005B	420	900		
4C0000006B	420	1000		
4C0000008B	420	1250		
4C0000009B	420	1330		

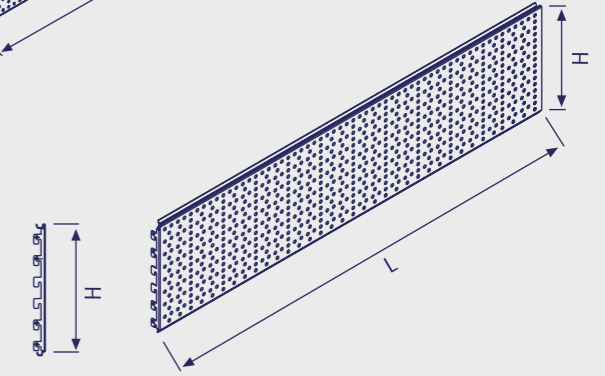
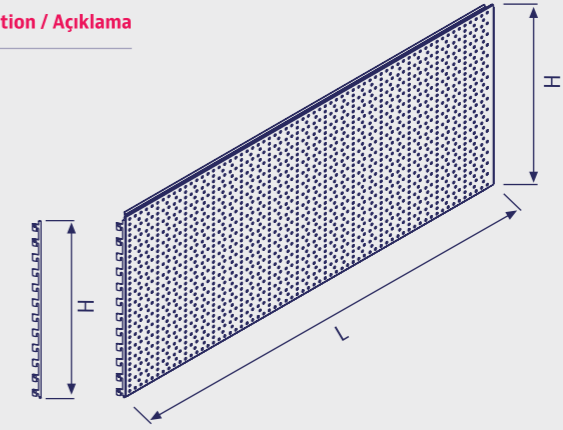

Code / Kod	P	H	L	Description / Açıklama
4C0000010B	210	500		
4C0000012B	210	700		
4C0000014B	210	900		
4C0000015B	210	1000		
4C0000017B	210	1250		
4C0000018B	210	1330		

**RIBBED BACK PANEL
RİBLİ ARKA PANO**

Code / Kod	P	H	L	Description / Açıklama
4B0000001B	420	500		
4B0000003B	420	700		
4B0000005B	420	900		
4B0000006B	420	1000		
4B0000008B	420	1250		
4B0000009B	420	1330		

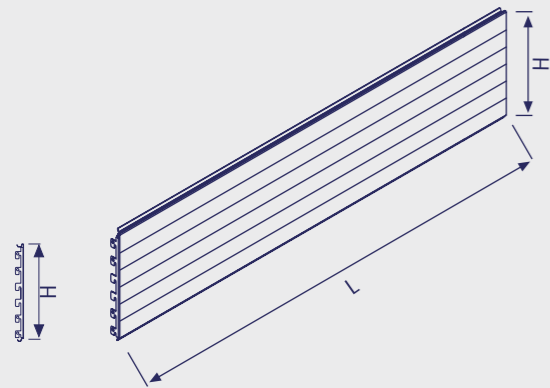
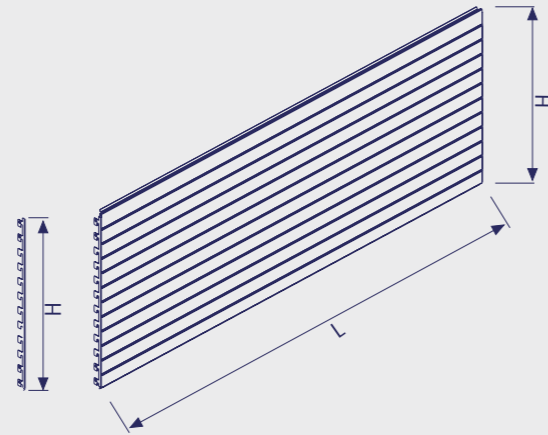

Code / Kod	P	H	L	Description / Açıklama
4B0000010B	210	500		
4B0000012B	210	700		
4B0000014B	210	900		
4B0000015B	210	1000		
4B0000017B	210	1250		
4B0000018B	210	1330		

**PLAIN BACK PANEL INTERNAL CORNER
DÜZ ARKA PANO İÇ KÖŞE**

Code / Kod	P	H	L	Description / Açıklama
4E0000001B	300	420	820	*For P:-300 P:-400 P:500 mm Base Shelves
	400	420	820	*P:300 P:400 P:500 mm Taban rafına göre
	500	420	820	*For P: 600 mm Base Shelf
4E0000002B	600	420	960	*P:600 mm Taban rafına göre
4E0000003B	300	210	820	
	400	210	820	*For P:-300 P:-400 P:500 mm Base Shelves
	500	210	820	*P:300 P:400 P:500 mm Taban rafına göre
4E0000004B	600	210	960	*For P: 600 mm Base Shelf
				*P:600 mm Taban rafına göre

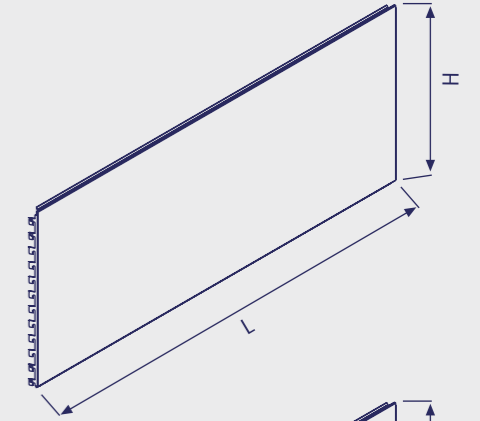

**PLAIN BACK PANEL INTERNAL CORNER 90°
DÜZ ARKA PANO İÇ KÖŞE 90°**

Code / Kod	P	H	L	Description / Açıklama
4F0000001B		210	690	Left / Sol
4F0000002B		420	690	Left / Sol
4F0000003B		210	690	Right / Sağ
4F0000004B		420	690	Right / Sağ

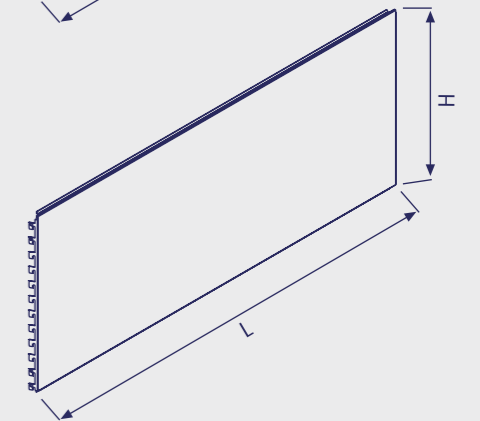

- 90 degree internal corner wall unit needs right&left back panel set.
- 90 derece iç köşe duvar reyonu için sağ ve sol arka pano takım olarak kullanılır.



**SHELVING
SYSTEMS**
RAF SİSTEMLERİ

PERFORATED BACK PANEL INTERNAL CORNER
DELİKLİ ARKA PANO İÇ KÖŞE

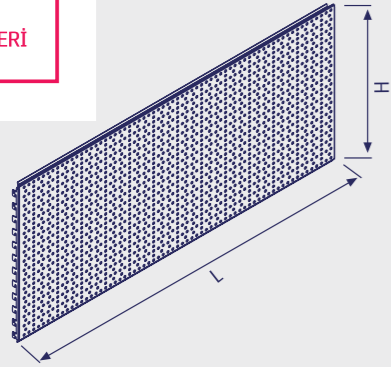

Code / Kod	P	H	L	Description / Açıklama
4J0000001B	300	420	820	*For P:-300 P:-400 P:500 mm Base Shelves *P:300 P:400 P:500 mm Taban rafına göre
	400	420	820	
	500	420	820	*For P: 600 mm Base Shelf
4J0000002B	600	420	960	*P:600 mm Taban rafına göre
4J0000003B	300	210	820	
	400	210	820	*For P:-300 P:-400 P:500 mm Base Shelves
	500	210	820	*P:300 P:400 P:500 mm Taban rafına göre
4J0000004B	600	210	960	*For P: 600 mm Base Shelf *P:600 mm Taban rafına göre

PLAIN BACK PANEL EXTERNAL CORNER
DÜZ ARKA PANO DIŞ KÖŞE

Code / Kod	P	H	L	Description / Açıklama
4D0000001B		210	122	
4D0000002B		420	122	



PERFORATED BACK PANEL EXTERNAL CORNER
DELİKLİ ARKA PANO DIŞ KÖŞE

Code / Kod	P	H	L	Description / Açıklama
4G0000001B		210	122	
4G0000002B		420	122	

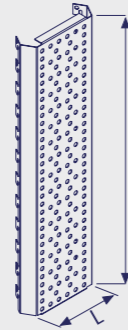

PROFILE BACK PANEL FOR 30X80 UPRIGHT
PROFİL ARKA PANO 30X80 DİKME İÇİN

Code / Kod	P	H	L	Description / Açıklama
4N00000025B		210	500	*20x30 mm profile / profil
4N00000026B		210	700	
4N00000027B		210	900	
4N00000028B		210	1000	
4N00000029B		210	1250	
4N00000030B		210	1330	

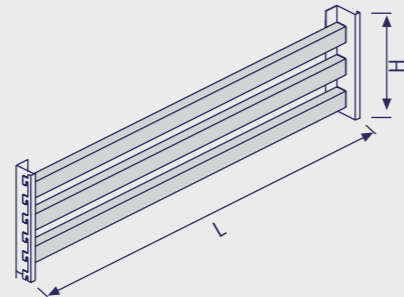

PROFILE BACK PANEL
PROFİL ARKA PANO

Code / Kod	P	H	L	Description / Açıklama
4N00000031B		420	500	*20x30 mm profile / profil
4N00000032B		420	700	
4N00000033B		420	900	
4N00000034B		420	1000	
4N00000035B		420	1250	
4N00000036B		420	1330	

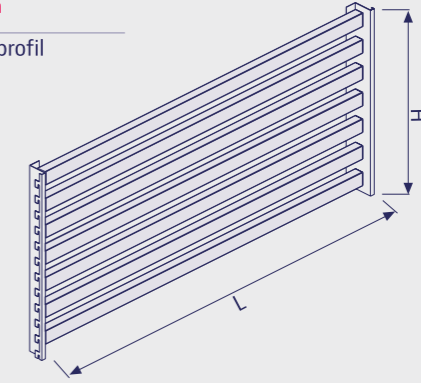

**SHELVING
SYSTEMS**
RAF SİSTEMLERİ

GONDOLA HEAD FIXING PART SET
GONDOLBAŞI BAĞLANTI TAKIMI

Code / Kod	P	H	L	Description / Açıklama
19A0000001T			500	Thickness / Sac kalınlığı 2.5 mm
19A0000002T			700	
19A0000003T			900	
19A0000004T			1000	
19A0000005T			1250	
19A0000006T			1330	

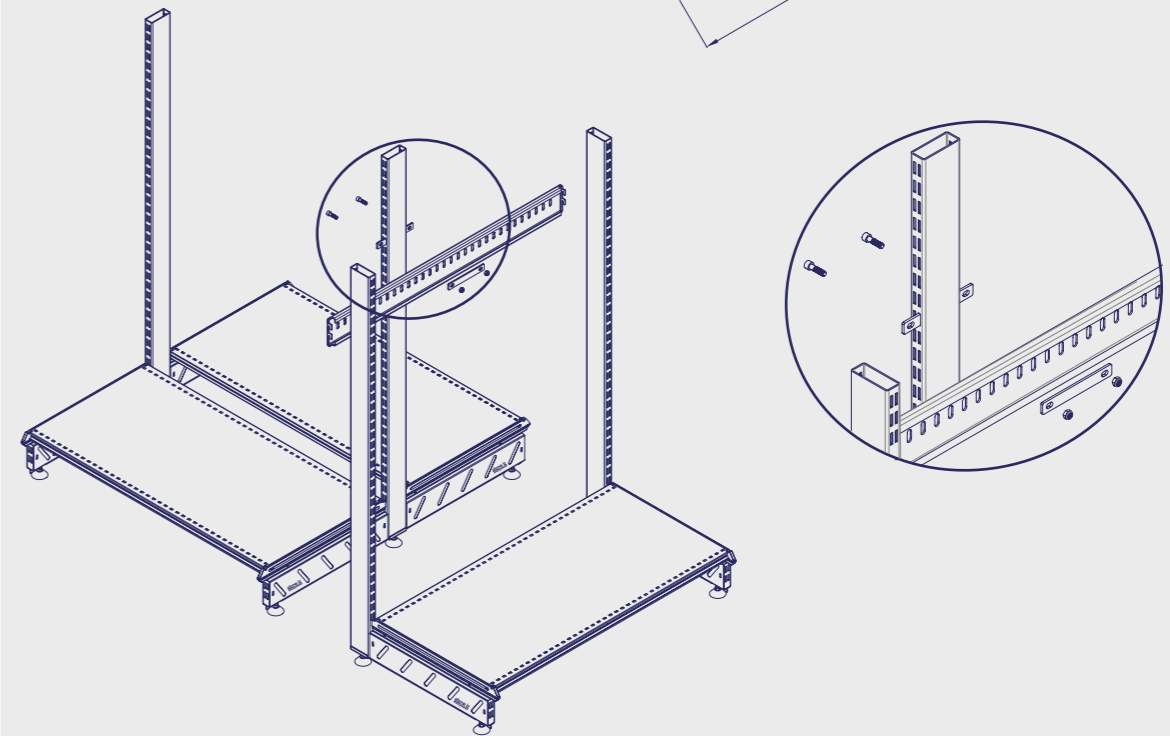
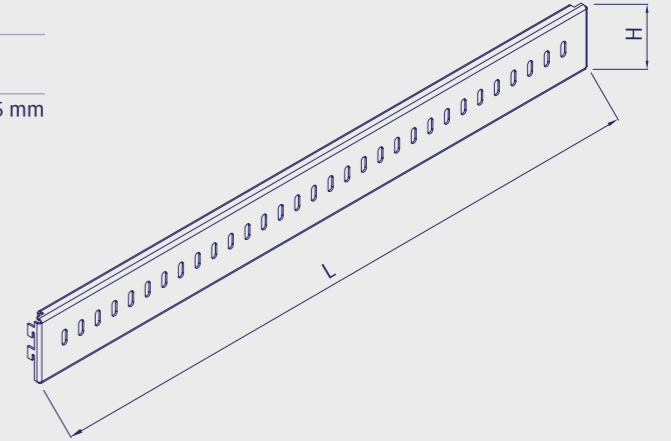



**SHELVING
SYSTEMS
RAF SİSTEMLERİ**

**SHELF
RAF**

Code / Kod	P	H	L	Description / Açıklama
5A00000013B	200		500	
5A00000016B	200		700	
5A00000019B	200		900	
5A00000021B	200		1000	
5A00000025B	200		1250	
5A00000027B	200		1330	

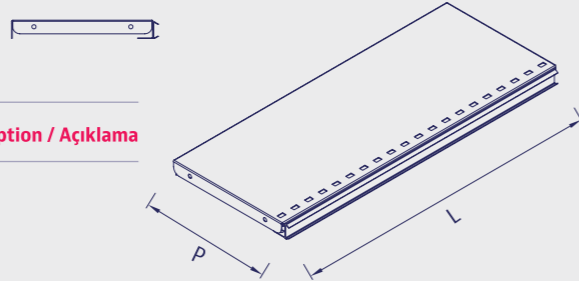

**SHELF
RAF**

Code / Kod	P	H	L	Description / Açıklama
5A00000036B	300		500*	*300x500 & 300x700 and 300x900 mm shelves are without support.
5A00000039B	300		700*	
5A00000043B	300		900*	*300x500 300x700 ve 300x900 mm raflar takviyesizdir.
5A00000045B	300		1000	
5A00000047B	300		1250	
5A00000048B	300		1330	

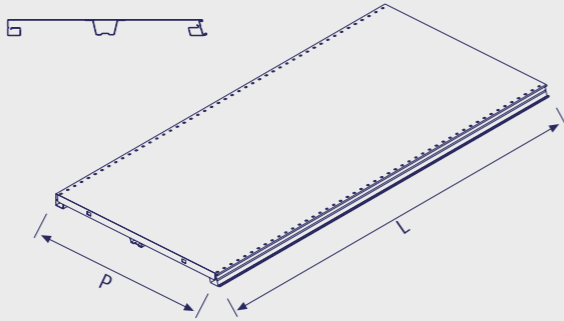

**SHELF
RAF**

Code / Kod	P	H	L	Description / Açıklama
5A00000051B	400		500	
5A00000055B	400		700	
5A00000060B	400		900	
5A00000062B	400		1000	
5A00000065B	400		1250	
5A00000066B	400		1330	

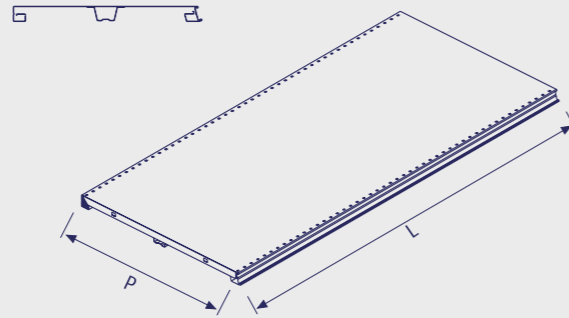

**SHELF
RAF**

Code / Kod	P	H	L	Description / Açıklama
5A00000067B	500		500	
5A00000069B	500		700	
5A00000071B	500		900	
5A00000072B	500		1000	
5A00000074B	500		1250	
5A00000075B	500		1330	

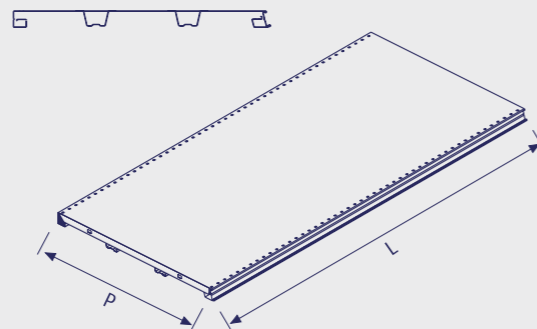

**SHELF
RAF**

Code / Kod	P	H	L	Description / Açıklama
5A00000076B	600		500	
5A00000078B	600		700	
5A00000079B	600		900	
5A00000080B	600		1000	
5A00000083B	600		1250	
5A00000084B	600		1330	

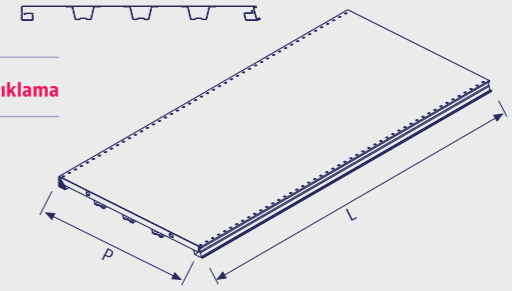

**SHELF
RAF**

Code / Kod	P	H	L	Description / Açıklama
5A00000085B	700		500	
5A00000086B	700		700	
5A00000087B	700		900	
5A00000088B	700		1000	
5A00000089B	700		1250	
5A00000090B	700		1330	

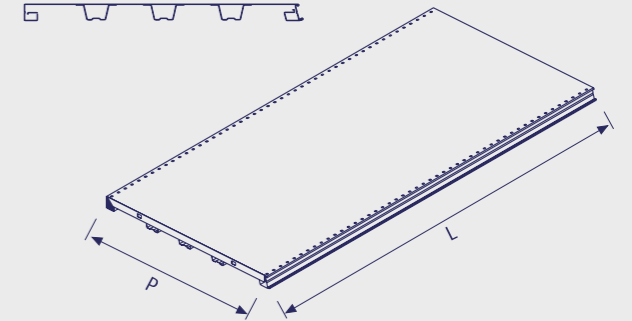

**SHELF INTERNAL CORNER
İÇ KÖŞE RAF**

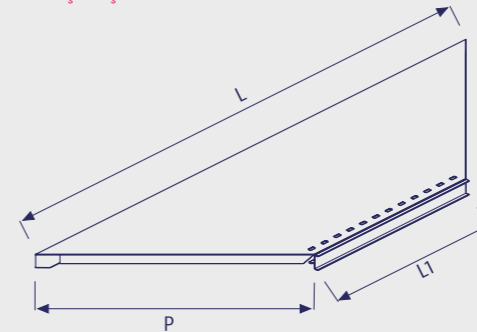

Code / Kod	P	H	L	L1	Description / Açıklama
5B00000001B	300		820	420	*L: 820 mm
5B00000002B	400		820	290	Shelves will be used with P: 300 P: 400 P: 500 Base Shelf
5B00000003B	500		820	150	L: 820 mm
5B00000004B	300		965	580	* L: 820 mm raflar P:300 P:400
5B00000005B	400		965	420	P: 500 taban rafı ile kullanılır.
5B00000006B	500		965	295	* L: 965 mm
5B00000007B	600		965	148	Shelves will be used with P: 600 Base Shelf
					* L: 965 mm raflar P: 600 taban rafı ile kullanılır.

**SHELF EXTERNAL CORNER
DIŞ KÖŞE RAF**

Code / Kod	P	H	L	L1	Description / Açıklama
5C00000001B	300		190	540	
5C00000002B	400		190	700	
5C00000003B	500		190	840	
5C00000004B	600		190	980	

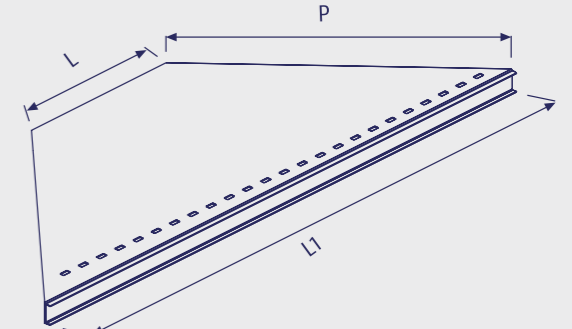

**SHELVING
SYSTEMS
RAF SİSTEMLERİ**



**SHELVING
SYSTEMS**
RAF SİSTEMLERİ

SHELF INTERNAL CORNER 90°
İÇ KÖŞE 90° RAF

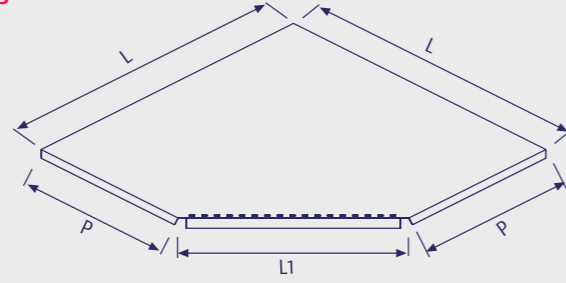

Code / Kod	P	H	L	L1	Description / Açıklama
5B00000008B	200		700	719	
5B00000009B	300		700	600	
5B00000010B	400		700	445	
5B00000011B	500		700	315	
5B00000012B	600		700	185	

WOODEN BRACKET
AĞAÇ KONSOL

Code / Kod	P	H	L	Description / Açıklama
6B00000001B	200			Sağ
6B00000003B	300			
6B00000005B	400			
6B00000007B	500			
6B00000002B	200			Sol
6B00000004B	300			
6B00000006B	400			
6B00000008B	500			

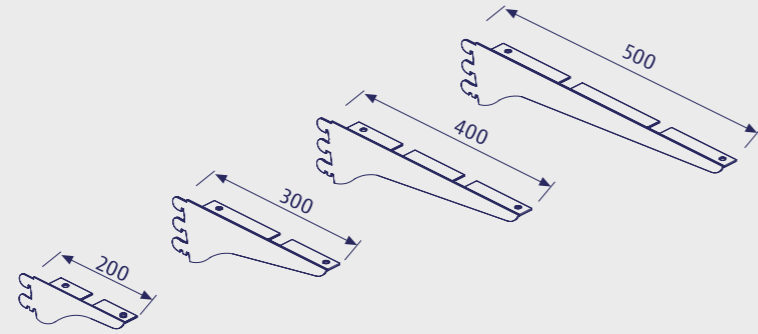

BRACKET FOR WOODEN SHELF WITH 2 HOLDERS
AĞAÇ RAF KONSOL 2 TIRNAKLI

Code / Kod	P	H	L	Description / Açıklama
6B00000009B	200			Sağ
6B00000011B	300			
6B00000013B	400			
6B00000015B	500			
6B00000010B	200			Sol
6B00000012B	300			
6B00000014B	400			
6B00000016B	500			

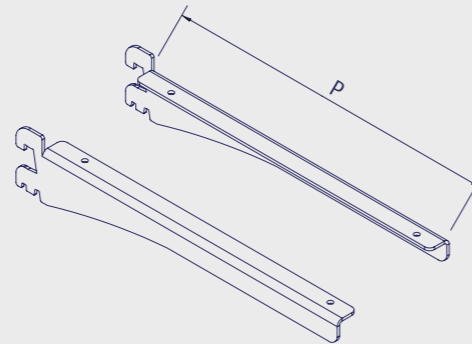

**SHELVING
SYSTEMS**
RAF SİSTEMLERİ

BRACKET
KONSOL

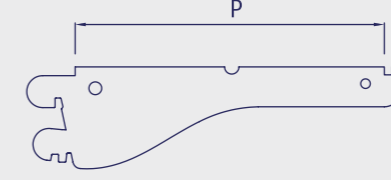

Code / Kod	P	H	L	Description / Açıklama
6A00000002B	200			

BRACKET
KONSOL

Code / Kod	P	H	L	Description / Açıklama
6A00000004B	300			
6A00000005B	400			

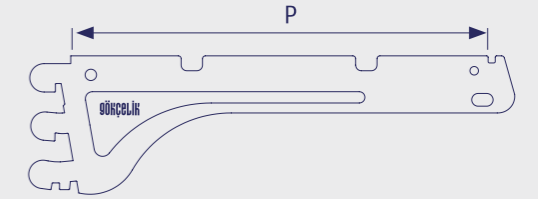

BRACKET
KONSOL

Code / Kod	P	H	L	Description / Açıklama
6A00000006B	500			

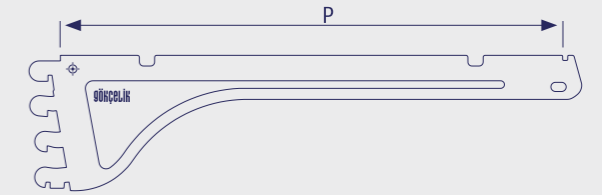

BRACKET
KONSOL

Code / Kod	P	H	L	Description / Açıklama
6A00000007B	600			
6A00000009B	700			

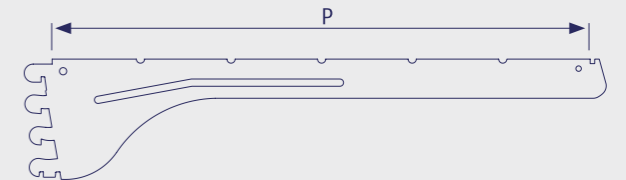



**SHELVING
SYSTEMS
RAF SİSTEMLERİ**

FRAME FOR OVAL GLASS SHELF
OVAL CAM RAF İSKELET

Code / Kod	P	H	L	Description / Açıklama
6D00000021B	300	500		* Will be used with 6mm and 8 mm glass shelf.
6D00000022B	300	700		
6D00000023B	300	900		* 6 mm ve 8 mm oval cam raf ile kullanılır.
6D00000024B	300	1000		

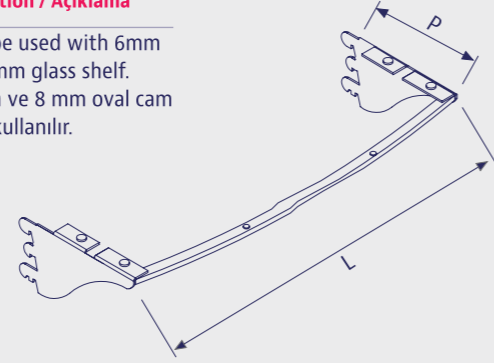

FRAME FOR GLASS SHELF
CAM RAF İSKELET

Code / Kod	P	H	L	Description / Açıklama
6D00000001B	200	500		With single support Tek destekli
6D00000002B	200	700		
6D00000003B	200	900		
6D00000004B	200	1000		
6D00000005B	200	1250		
6D00000006B	300	500		With single support Tek destekli
6D00000007B	300	700		
6D00000008B	300	900		
6D00000009B	300	1000		
6D00000010B	300	1250		

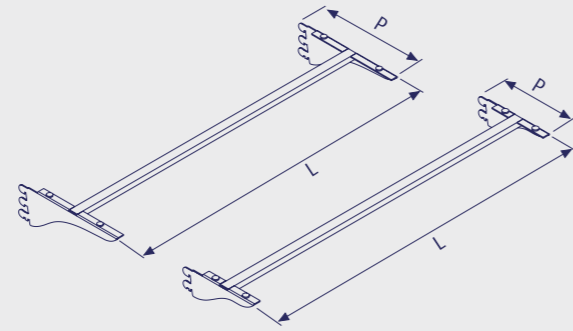

FRAME FOR GLASS SHELF
CAM RAF İSKELET

Code / Kod	P	H	L	Description / Açıklama
6D00000011B	400	500		With double support Çift destekli
6D00000012B	400	700		
6D00000013B	400	900		
6D00000014B	400	1000		
6D00000015B	400	1250		
6D00000016B	500	500		
6D00000017B	500	700		
6D00000018B	500	900		
6D00000019B	500	1000		
6D00000020B	500	1250		

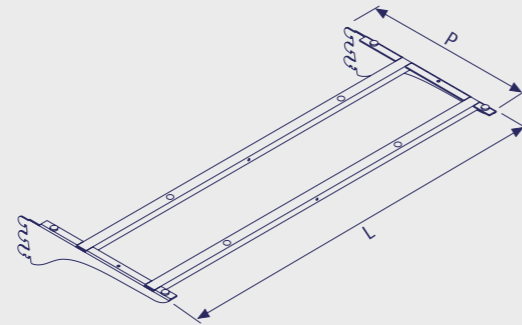

**SHELVING
SYSTEMS
RAF SİSTEMLERİ**

FRAME FOR GLASS SHELF (SUITABLE FOR LIGHTING&STANDARD LABEL HOLDER)
CAM RAF İSKELET (AYDINLATMALI VE STANDART RAF ETİKETLİĞİNE UYGUN)

Code / Kod	P	H	L	Description / Açıklama
6E00000006U	300	500		
6E00000007U	300	700		
6E00000008U	300	900		
6E00000009U	300	1000		
6E00000010U	300	1250		
6E00000011U	400	500		
6E00000012U	400	700		
6E00000013U	400	900		
6E00000014U	400	1000		
6E00000015U	400	1250		
6E00000016U	500	500		
6E00000017U	500	700		
6E00000018U	500	900		
6E00000019U	500	1000		
6E00000020U	500	1250		

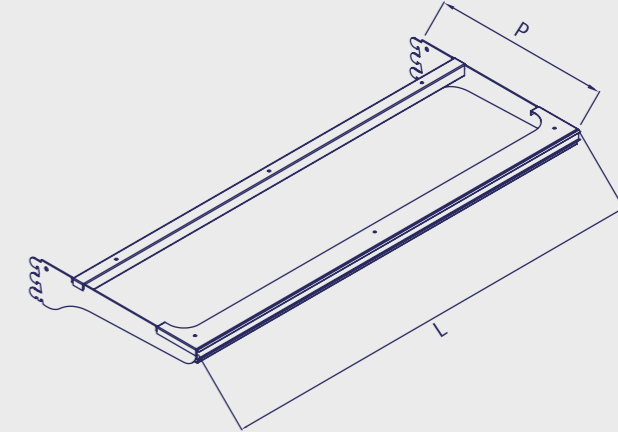

FRONT PANEL
ALT ÖN PANEL

Code / Kod	P	H	L	Description / Açıklama
10A0000001B		100	500	
10A0000003B		100	700	
10A0000005B		100	900	
10A0000006B		100	1000	
10A0000008B		100	1250	
10A0000009B		100	1330	

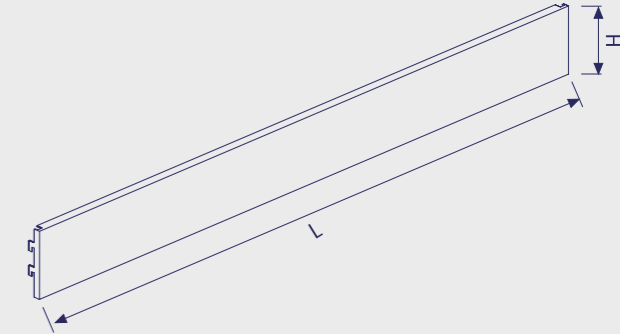

FRONT PANEL EXTERNAL CORNER
DIŞ KÜŞE ALT ÖN PANEL

Code / Kod	P	H	L	Description / Açıklama
10A0000022B	300	100		
10A0000023B	400	100		
10A0000024B	500	100		
10A0000025B	600	100		

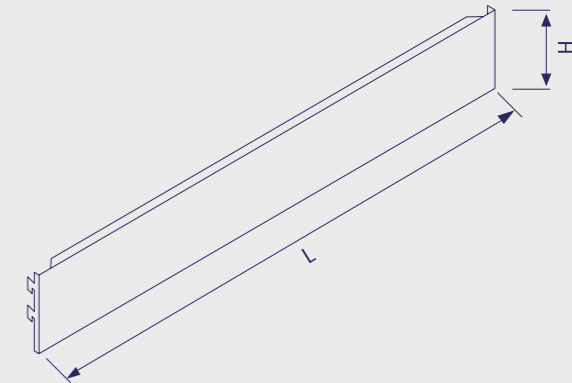



**SHELVING
SYSTEMS**
RAF SİSTEMLERİ

FRONT PANEL INTERNAL CORNER
İÇ KÖŞE ALT ÖN PANEL

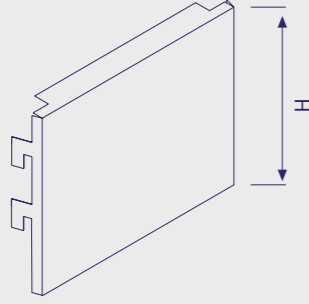

Code / Kod	P	H	L	Description / Açıklama
10A0000015B	300	100		For internal corner İç köşe için
10A0000016B	400	100		
10A0000017B	500	100		
10A0000017B	600	100		
10A0000018B	300	100		
10A0000019B	400	100		For internal corner 90° İç köşe 90° için
10A0000020B	500	100		
10A0000021B	600	100		
10A0000021B	600	100		

TOP COVER FOR GONDOLA
ORTA REYON KAPAĞI

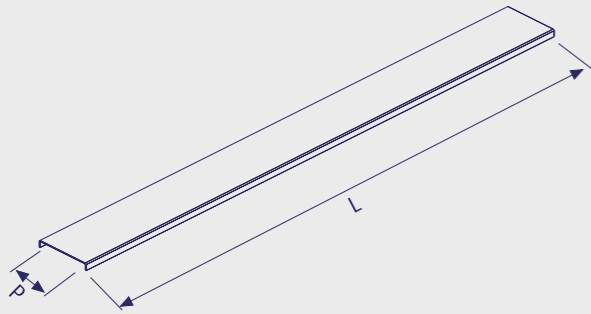

Code / Kod	P	H	L	Description / Açıklama
10B0000001B	600	500		*For 30x60 Upright *30x60 Dikme için
10B0000003B	600	700		
10B0000005B	600	900		
10B0000006B	600	1000		
10B0000008B	600	1250		
10B0000009B	600	1330		
10B0000010B	800	500		*For 30x80 Upright *30x80 Dikme için
10B0000012B	800	700		
10B0000014B	800	900		
10B0000015B	800	1000		
10B0000017B	800	1250		
10B0000018B	800	1330		

TOP COVER FOR GONDOLA WITH PLEXY CHANNEL
ORTA REYON KAPAĞI PLEKSİ KANALLI

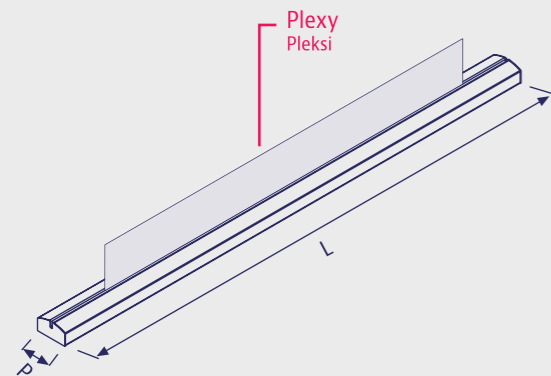

Code / Kod	P	H	L	Description / Açıklama
10B0000130U	600	500		*For 30x60 Upright *30x60 Dikme için
10B0000132U	600	700		
10B0000134U	600	900		
10B0000135U	600	1000		
10B0000137U	600	1250		
10B0000138U	600	1330		
10B0000139U	800	500		*For 30x80 Upright *30x80 Dikme için
10B0000141U	800	700		
10B0000143U	800	900		
10B0000144U	800	1000		
10B0000145U	800	1250		
10B0000146U	800	1330		

TOP COVER FOR GONDOLA FOR ADVERTISEMENT
ORTA REYON KAPAĞI GÖRSELLİ

Code / Kod	P	H	L	Description / Açıklama
10B0000028B	120	500		* Metal 30x60 Profil için
10B0000030B	120	700		
10B0000032B	120	900		
10B0000033B	120	1000		
10B0000035B	120	1250		
10B0000036B	120	1330		
10B0000037B	120	500		* Metal 30x80 Profil için
10B0000039B	120	700		
10B0000041B	120	900		
10B0000042B	120	1000		
10B0000044B	120	1250		
10B0000045B	120	1330		

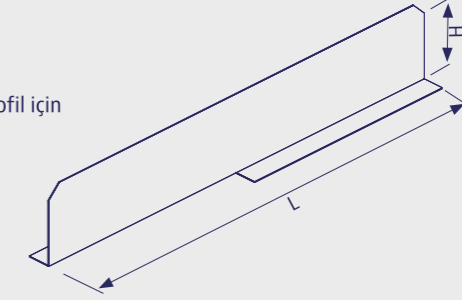

TOP COVER FOR GONDOLA WITH CLICK
ORTA REYON KAPAĞI KİLİTLİ

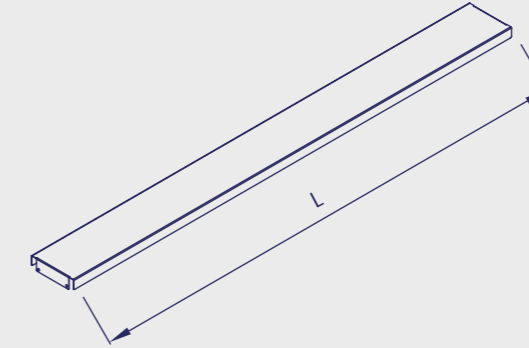

Code / Kod	P	H	L	Description / Açıklama
10B0000046B	600	500		For 30x60 Upright 30x60 Dikme için
10B0000048B	600	700		
10B0000050B	600	900		
10B0000051B	600	1000		
10B0000053B	600	1250		
10B0000054B	600	1330		
10B0000055B	800	500		For 30x80 Upright 30x80 Dikme için
10B0000057B	800	700		
10B0000059B	800	900		
10B0000060B	800	1000		
10B0000062B	800	1250		
10B0000063B	800	1330		

FRONT BARRIER
REYON ÖNÜ BARIYER

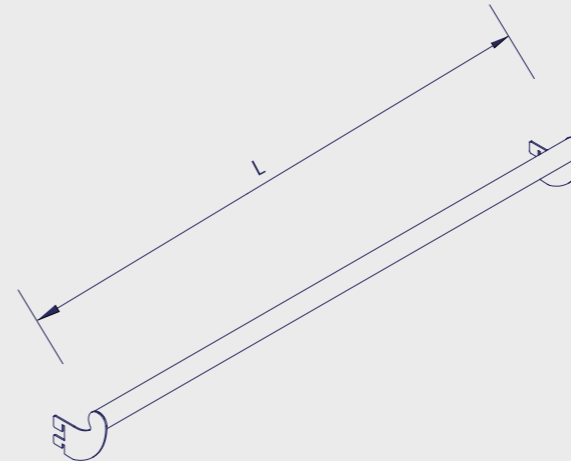

Code / Kod	P	H	L	Description / Açıklama
12H0000001N		500		* Nickel Coated
12H0000003N		700		* Nikel Kaplama
12H0000005N		900		* For Front Barrier, Metal part Will be Wlded in Front of Base Leg
12H0000006N		1000		
12H0000008N		1250		
12H0000009N		1330		* Reyon önü bariyer için Geçme Ayağın önüne sac parçacı kaynatılacaktır.



**SHELVING
SYSTEMS**
RAF SİSTEMLERİ

PVC LABEL HOLDER
PVC RAF ETİKETLİĞİ

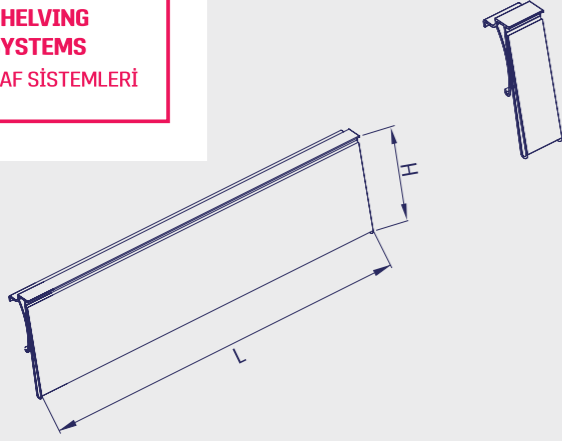

Code / Kod	P	H	L	Description / Açıklama
92000000351		39	500	
92000000476		39	700	
92000000601		39	900	
92000000626		39	1000	
92000000151		39	1250	
92000000176		39	1330	
92000000651		60	500	
92000000676		60	700	
92000000701		60	900	
92000000726		60	1000	
92000000751		60	1250	
92000000776		60	1330	

PVC LABEL HOLDER FOR GLASS SHELF
PVC CAM RAF ETİKETLİĞİ

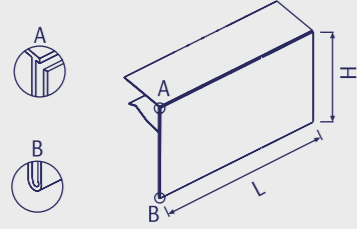

Code / Kod	P	H	L	Description / Açıklama
92000001507		39	500	*Transparent
92000001557		39	700	*Şeffaf
92000001632		39	900	
92000001682		39	1000	
92000001707		39	1250	

PVC LABEL HOLDER INTERNAL CORNER 90°
PVC RAF ETİKETLİĞİ 90°

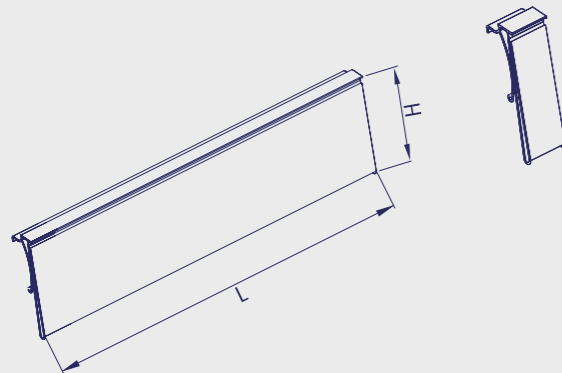

Code / Kod	P	H	L	Description / Açıklama
92000004266	300	39	390	
92000004267	400	39	255	
92000004268	500	39	120	
92000004269	600	39	120	

PVC STICKABLE LABEL HOLDER
PVC YAPIŞTIRMALI ETİKETLİK

Code / Kod	P	H	L	Description / Açıklama
92000002832		39	500	Transparent
92000002882		39	700	Şeffaf
92000002932		39	900	
92000002982		39	1000	
92000003057		39	1250	

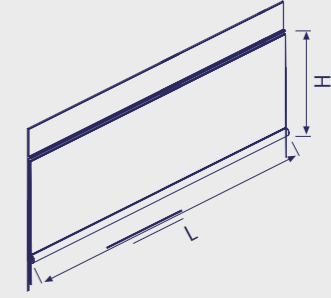

PVC LABEL HOLDER FOR WIRE SHELF
PVC TEL RAF ETİKETLİĞİ

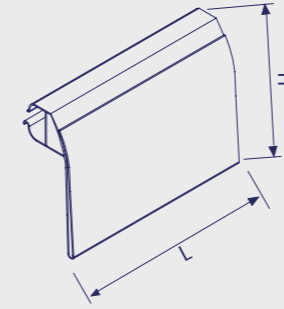

Code / Kod	P	H	L	Description / Açıklama
92000002432		39	500	Transparent
92000002457		39	700	Şeffaf
92000002482		39	900	
92000002507		39	1000	
92000002532		39	1250	
92000002557		39	1330	

PVC LABEL HOLDER INTERNAL CORNER
PVC RAF ETİKETLİĞİ İÇ KÖŞE

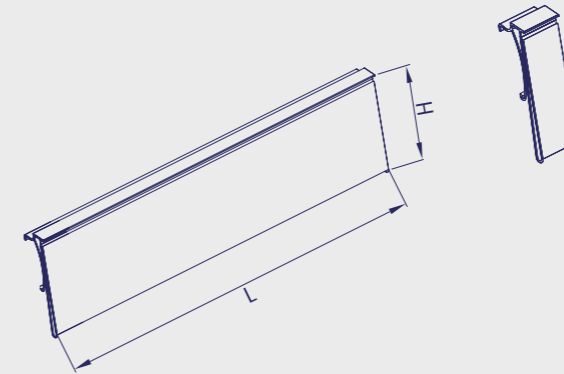

Code / Kod	P	H	L	Description / Açıklama
92000004255	300	39	390	
92000004255	400	39	255	
92000004256	500	39	120	
92000004257	600	39	120	



**SHELVING
SYSTEMS**
RAF SİSTEMLERİ



**SHELVING
SYSTEMS**
RAF SİSTEMLERİ

PVC LABEL HOLDER EXTERNAL CORNER
PVC RAF ETİKETLİĞİ DIŞ KÖŞE

Code / Kod	P	H	L	Description / Açıklama
92000004262	300	39	525	
92000004263	400	39	650	
92000004264	500	39	805	
92000004265	600	39	930	

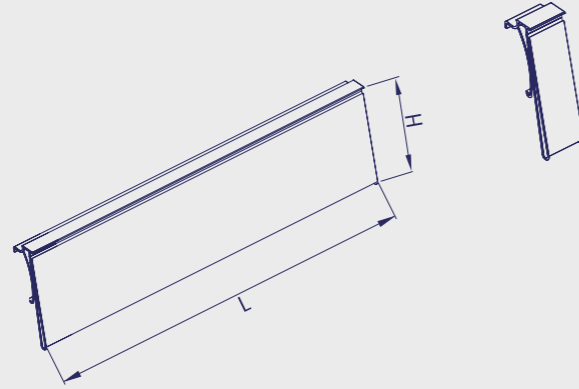

RIBBON
RENKLİ İÇ ŞERİT

Code / Kod	P	H	L	Description / Açıklama
92000003461		39		RAL 3020 Red / Kırmızı
92000003465		39		RAL 1023 Yellow / Sarı
92000003467		39		RAL 5010 Blue / Mavi
92000003469		39		RAL 6024 Green / Yeşil
92000003462		39		RAL 2004 Orange / Turuncu
92000003471		39		RAL 7001 Grey / Gri

* Will be used with transparent label holder.
* Şeffaf raf etiketliğiyle kullanılır.

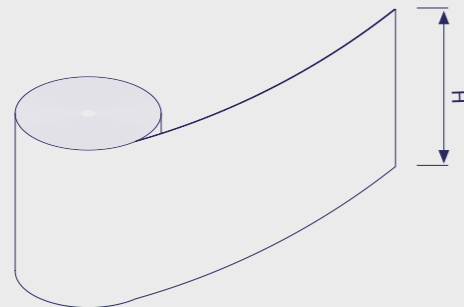

**SHELVING
SYSTEMS**
RAF SİSTEMLERİ

WALL UNIT
DUVAR ÜNİTESİ

H: 2060 mm L: 1000 mm
400B / 300 / 300 / 300 / 300
Unit Code: 9A00000018U

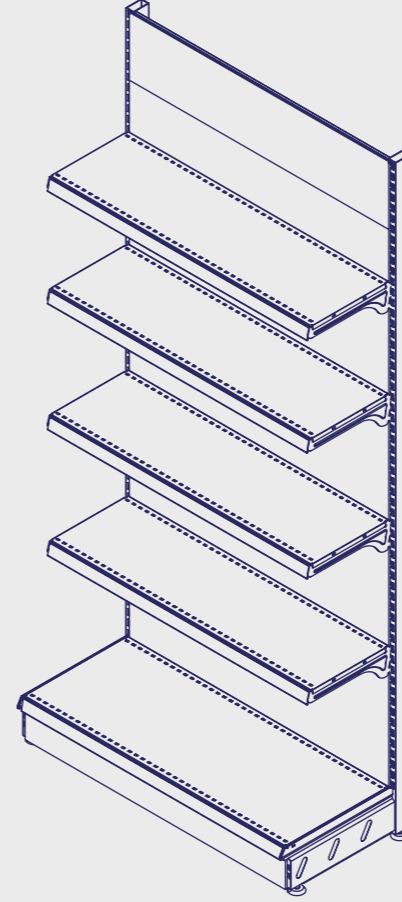

Code / Kod	Qty	P	H	L	Description / Açıklama
1B00000006B	1		2060		Upright 30x60
2A00000006B	1	400			Base Leg
4A00000006B	4		420	1000	Back Panel
4A00000015B	1		210	1000	Back Panel
5A00000062B	1	400		1000	Shelf
5A00000045B	4	300		1000	Shelf
6A00000004B	8	300			Bracket
10A0000006B	1			1000	Front Panel
92000000626	5			1000	Label Holder
92000003461	5			1000	Ribbon

Code / Kod	Qty	P	H	L	Ending Part / Bitiş Takımı
1B00000006B	1		2060		Upright 30x60
2A00000006B	1	400			Base Leg

WALL UNIT
DUVAR ÜNİTESİ

H: 2270 mm L: 1000 mm
500B / 400 / 400 / 400 / 400
Unit Code: 9A00000019U

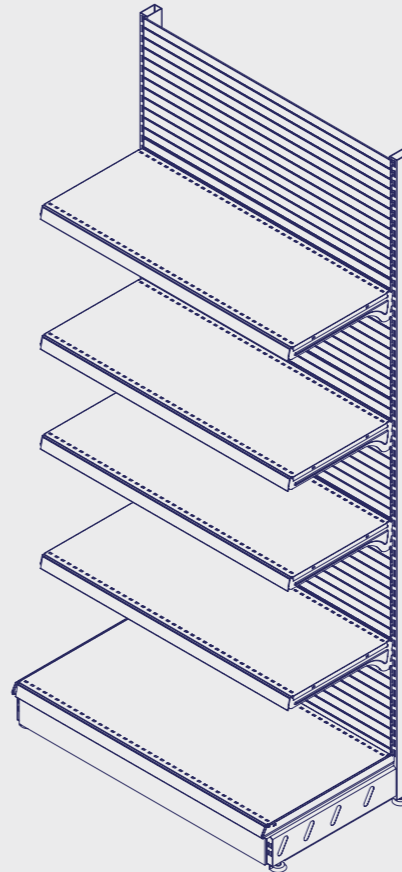

Code / Kod	Qty	P	H	L	Description / Açıklama
1B00000007B	1		2270		Upright 30x60
2A00000007B	1	500			Base Leg
4B00000006B	5		420	1000	Ribbed Back Panel
5A00000072B	1	500		1000	Shelf
5A00000062B	4	400		1000	Shelf
6A00000005B	8	400		1000	Bracket
10A0000006B	1			1000	Front Panel
92000000626	5			1000	Label Holder
92000003461	5			1000	Ribbon

Code / Kod	Qty	P	H	L	Ending Part / Bitiş Takımı
1B00000007B	1		2270		Upright 30x60
2A00000007B	1	500			Base Leg



**SHELVING
SYSTEMS
RAF SİSTEMLERİ**

**GONDOLA UNIT
GONDOL ÜNİTESİ**

H: 1850 mm L: 1000 mm
(500B / 400 / 400 / 400 / 400) x 2
Unit Code: 9A0000024U

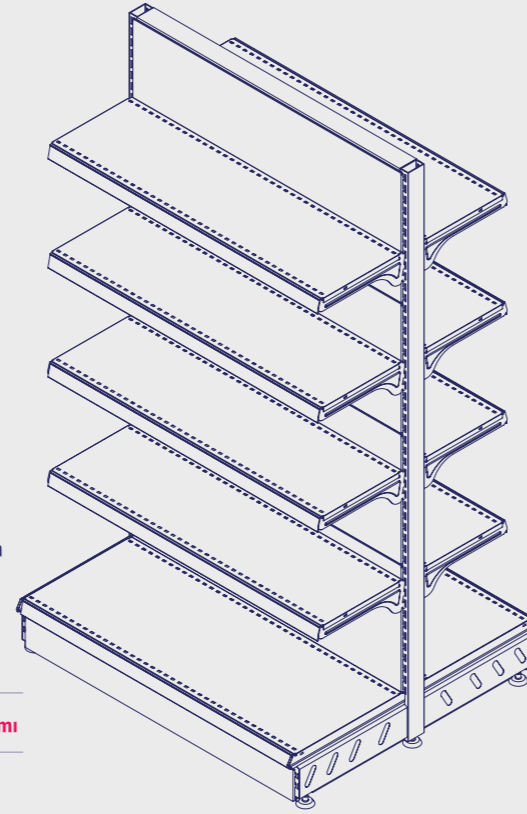

Code / Kod	Qnt	P	H	L	Description / Açıklama
1A00000005B	1		1850		Upright 30x60
2A00000007B	2	500			Base Leg
4A00000006B	8		420	1000	Back Panel
5A00000072B	2	500		1000	Shelf
5A00000062B	8	400		1000	Shelf
6A00000005B	16	400			Bracket
10A0000006B	2			1000	Front Panel
10B0000006B	1			1000	Top Cover For Gondola
9200000626	10				30x60 Label Holder
92000003465	10			1000	Ribbon

Code / Kod	Qnt	P	H	L	Ending Part / Bitiş Takımı
1A00000005B	1		1850		Upright 30x60
2A00000007B	2	500			Base Leg

**GONDOLA HEAD UNIT
GONDOLBAŞI ÜNİTESİ**

H: 1850 mm L: 1000 mm
400B / 300 / 300 / 300 / 300
Unit Code: 9A0000025U

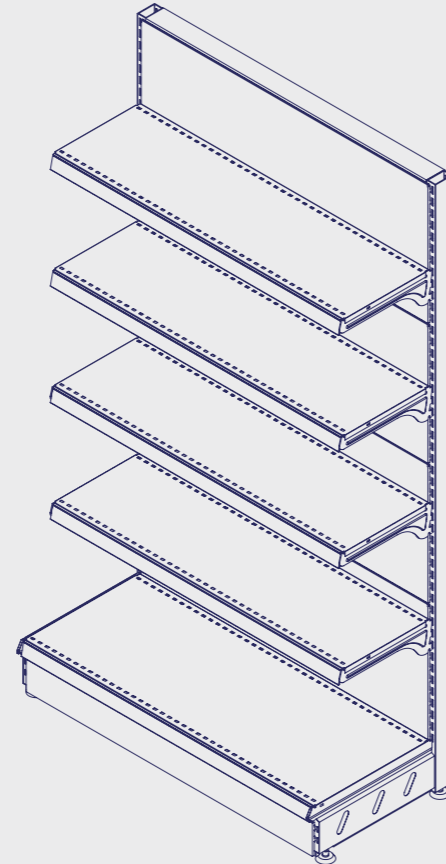

Code / Kod	Qnt	P	H	L	Description / Açıklama
1A00000005B	2		1850		Upright 30x60
2A00000006B	2	400			Base Leg
4A00000006B	8		420	1000	Back Panel
5A00000062B	1	400		1000	Shelf
5A00000045B	4	300		1000	Shelf
6A00000004B	8	300			Bracket
10A0000006B	1			1000	Front Panel
10B0000006B	1			1000	Top Cover For Gondola
9200000626	5				30x60 Label Holder
92000003465	5			1000	Ribbon



**SHELVING
SYSTEMS
RAF SİSTEMLERİ**

**WALL UNIT
DELİKLİ DUVAR ÜNİTESİ**

H: 2270 mm L: 1000 mm
500B / 400 /
Unit Code: 9A0000020U

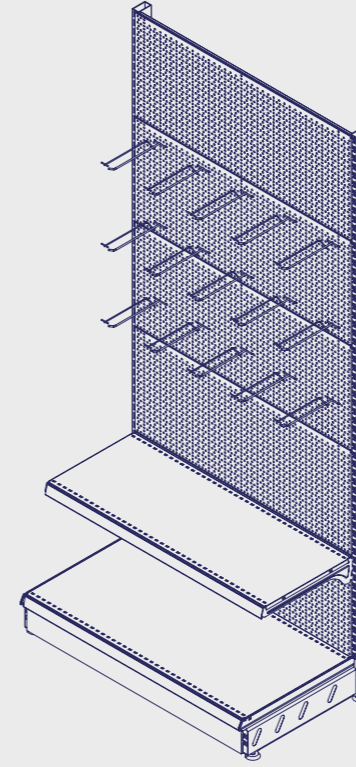

Code / Kod	Qnt	P	H	L	Description / Açıklama
1C00000007B	1		2270		Upright 30x80
2A00000007B	1	500	420		Base Leg
4C00000006B	5		420	1000	Perforated back panel
5A00000072B	1	500			Shelf
5A00000062B	1	400		1000	Shelf
6A00000005B	2	400			Bracket
10A0000006B	1				Front Panel
9200000626	5			1000	Label Holder
92000003467	5			1000	Ribbon
11C0000012N	15	300		1000	Wire hook for perforated back panel with label holder

Code / Kod	Qnt	P	H	L	Ending Part / Bitiş Takımı
1C00000007B	1		2270		Upright 30x60
2A00000007B	1	400			Base Leg

**WALL UNIT
DUVAR ÜNİTESİ**

H: 2270 mm L: 1000 mm
500B
Unit Code: 9A0000021U

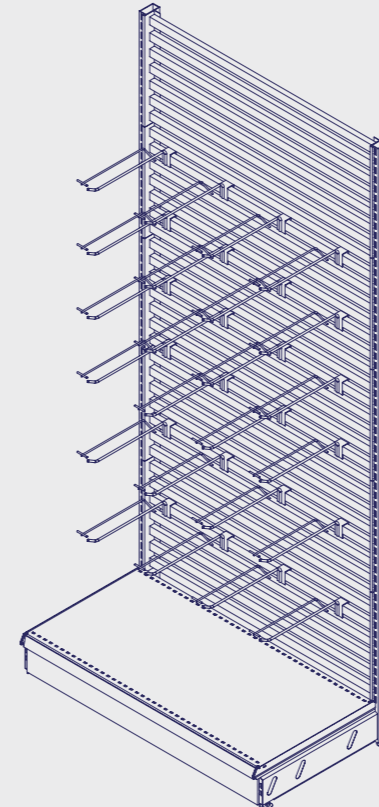

Code / Kod	Qnt	P	H	L	Description / Açıklama
1B00000007B	1		2270		Upright 30x60
2A00000007B	1	500			Base Leg
4N00000034B	5		420	1000	Profile Back Panel
5A00000072B	1	500		1000	Shelf
10A0000006B				1000	Front Panel
9200000626	5			1000	Label Holder
92000003467	5			1000	Ribbon
11C0000038N	24	300			Wire hook for profile back panel with label holder

Code / Kod	Qnt	P	H	L	Ending Part / Bitiş Takımı
1B00000007B	1		2270		Upright 30x60
2A00000007B	1	500			Base Leg

A

UNIT WITH FRONT UPRIGHT ÖN AYAKLI ÜNİTE

02

WALL UNIT WITH FRONT UPRIGHT DUVAR ÜNİTE ÖN AYAKLI

H: 2270 L: 1000 mm
(500 B / 500 / 500 / 500 / 500)



UNIT WITH
FRONT UPRIGHT
ÖN AYAKLI ÜNİTE

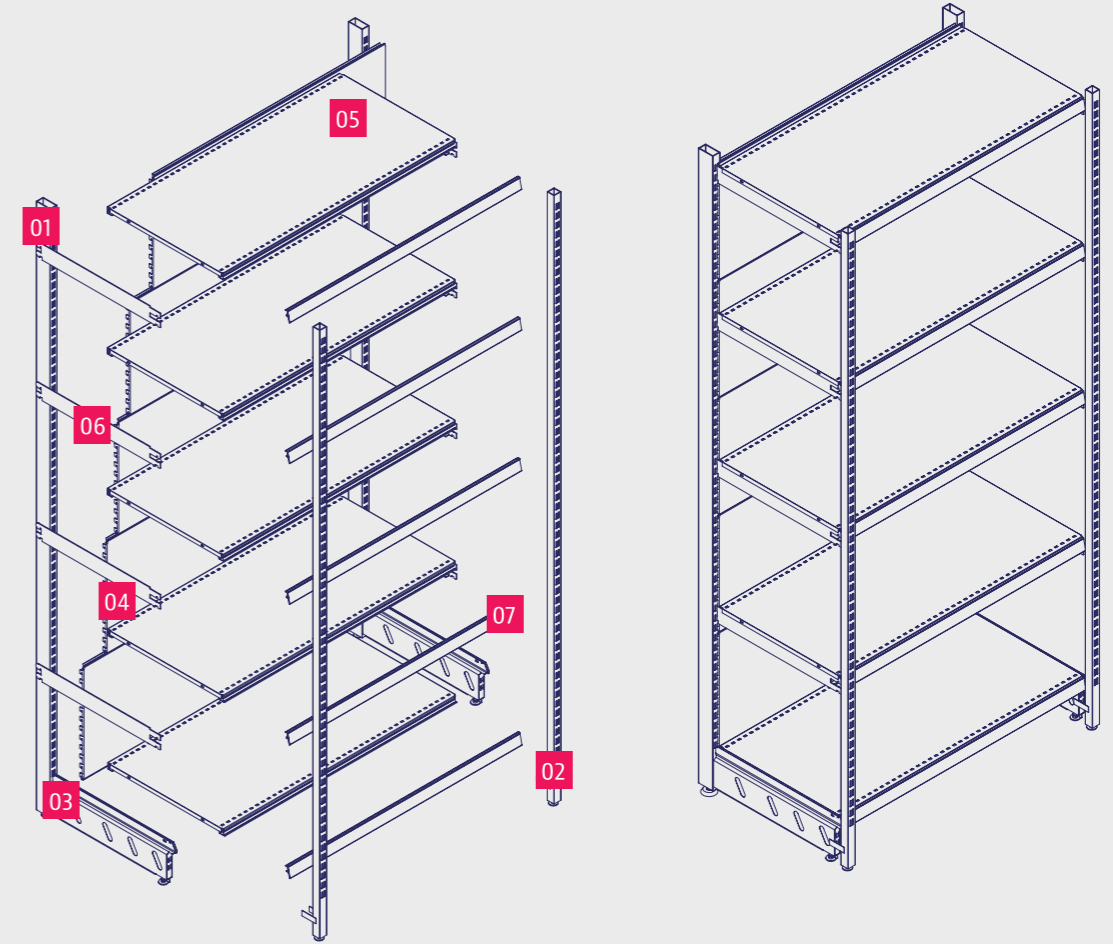

01
Upright Box Profile
Dikme Kutu Profil (Ref Section 2)

02
Front Upright 30x30
Ön Dikme 30x30

03
Base Leg
Geçme Ayak (Ref Section 2)

04
Back Panel
Arka Pano (Ref Section 2)

05
Shelf
Blok Raf (Ref Section 2)

06
Double Sided Bracket Set
Çift Taraflı Konsol Takımı

07
Label Holder
Raf Etiketliği (Ref Section 2)



**UNIT WITH
FRONT UPRIGHT**
ÖN AYAKLI ÜNİTE

GONDOLA UNIT
GONDOL ÜNİTESİ

H: 2270 mm
(900B / 900 / 900 / 900 / 900)

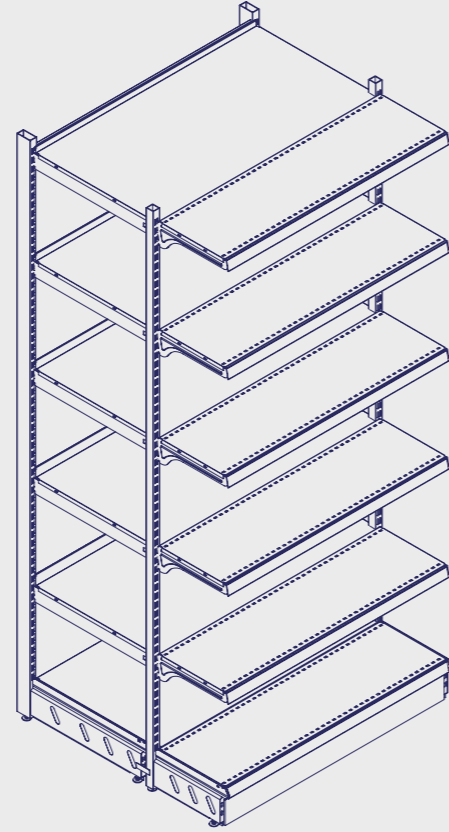
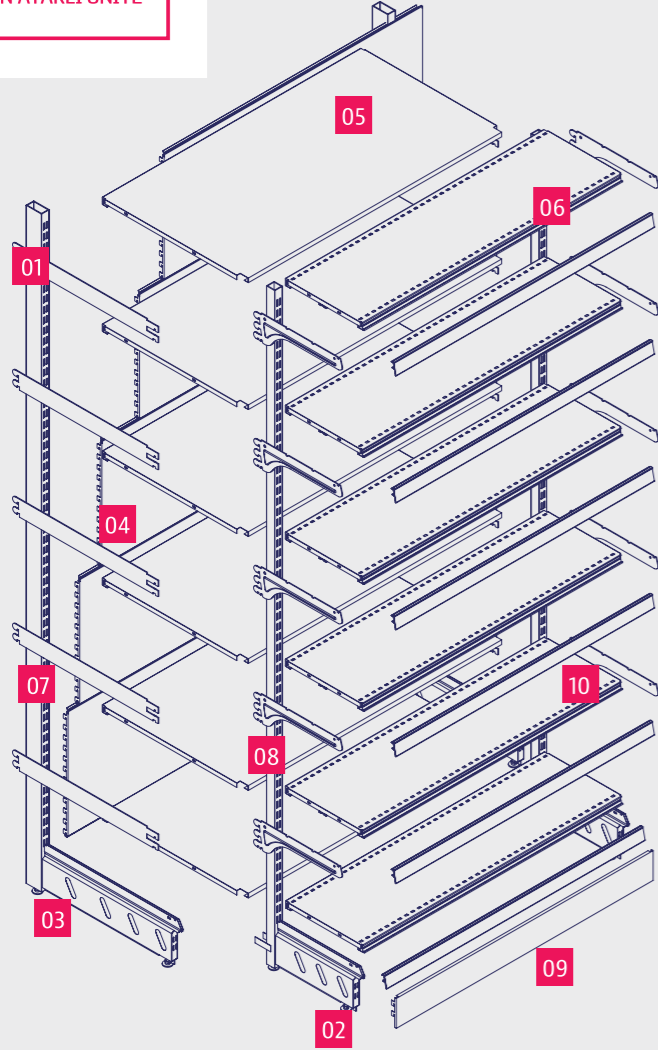

01
Upright Box Profile
Dikme Kutu Profil (Ref Section 2)

02
Front Upright For Double Shelving Unit
İkili Özel Ünite İçin Ön Ayak

03
Base Leg
Geçme Ayak (Ref Section 2)

04
Back Panel
Arka Pano (Ref Section 2)

05
Back Shelf for Double Shelving Unit (With Front Side Cut)
İkili Özel Ünite İçin Arka Raf

06
Shelf
Blok Raf (Ref Section 2)

07
Double Sided Bracket Set
Çift Taraflı Konsol Takımı

08
Bracket
Konsol (Ref Section 2)

09
Front Panel
Alt Ön Panel (Ref Section 2)

10
Label Holder
Etiketlik (Ref Section 2)



**UNIT WITH
FRONT UPRIGHT**
ÖN AYAKLI ÜNİTE

FRONT UPRIGHT WITHOUT HOLE 30x30
ÖN DİKME PENCERESİZ 30x30

Code / Kod	P	H	L	Description / Açıklama
1E0000001B		1430		
1E0000002B		1640		
1E0000003B		1850		
1E0000004B		2060		
1E0000005B		2270		
1E0000006B		2480		
1E0000007B		2690		

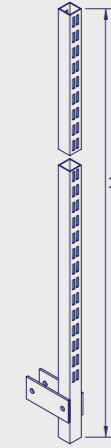

FRONT UPRIGHT FOR DOUBLE SHELVING UNIT 30x30
ÖN AYAK 30x30

Code / Kod	P	H	L	Description / Açıklama
3Q0000008B	200	135		* P: 600 P: 700 and P: 800 base legs will be welded to upright. Please contact with sales rep. for special situations.
3Q0000009B	300	135		
3Q0000010B	400	135		
3Q0000011B	500	135		
3Q0000012B	600*	135		* P: 600 P: 700 ve P: 800 geçme ayaklar dikmeye kaynaklı olacaktır. Özel durumlar için lütfen satış temsilcisi ile temasa geçiniz.
3Q0000013B	700*	135		
3Q0000014B	800*	135		

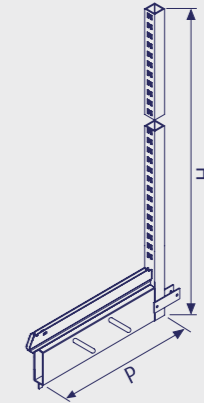

BASE LEG
GEÇME AYAK

Code / Kod	P	H	L	Description / Açıklama
2A0000003B	200	1430		
2A0000005B	300	1640		
2A0000006B	400	1850		
2A0000007B	500	2060		
2A0000008B	600*	2270		
2A0000009B	700*	2480		
2A0000010B	800*	2690		

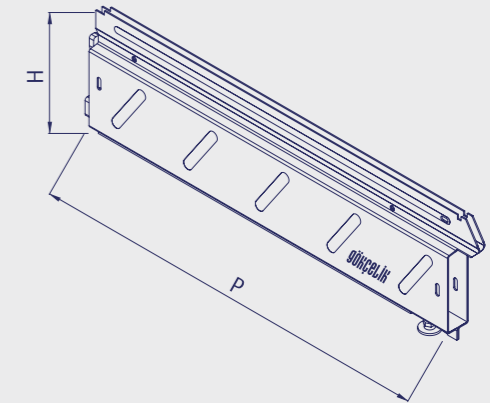

FOOT SCREW
ROTİL CIVATASI

Code / Kod	P	H	L	Description / Açıklama
9300000014				

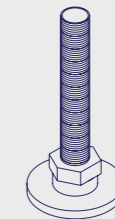



UNIT WITH
FRONT UPRIGHT
ÖN AYAKLI ÜNİTE

FOOT DISC
ROTİL SACI

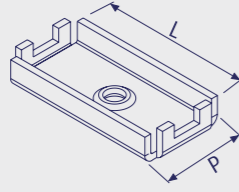

Code / Kod	P	H	L	Description / Açıklama
19D0000009G	37	31		
19D0000001G	37	61		
19D0000002G	37	81		
19D0000003G	37	101		

FRONT PLASTIC FOR BASE LEG
GEÇME AYAK ÖN PLASTİK

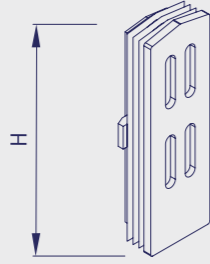

Code / Kod	P	H	L	Description / Açıklama
93000000030		85		Only black colour Siyah renk

PLASTIC PLUG FOR UPRIGHT
DİKME KAPAĞI

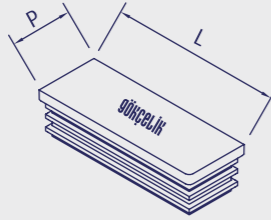

Code / Kod	P	H	L	Description / Açıklama
930000000705	30	30		
93000000024	30	60		
93000000022	30	80		
930000000706	30	100		

BRACKET
KONSOL

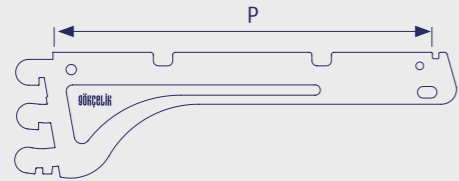

Code / Kod	P	H	L	Description / Açıklama
6A00000004B	300			

DOUBLE SIDED BRACKET
ÇİFT TARAFLI KONSOL

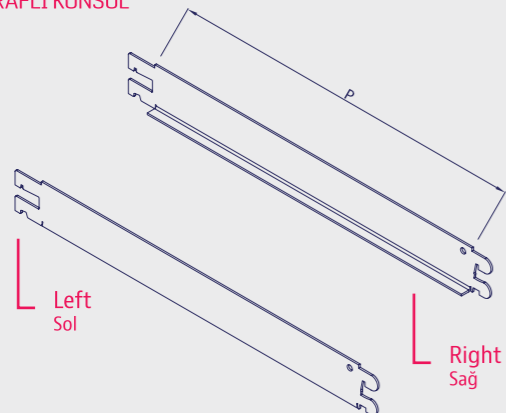

Code / Kod	P	H	L	Description / Açıklama
6C00000001B	320			* Right brackets * Sağ Konsol
6C00000003B	420			
6C00000005B	520			
6C00000007B	620			
6C00000009B	720			
6C00000002B	320			* Left brackets * Sol Konsol
6C00000004B	420			
6C00000006B	520			
6C00000008B	620			
6C00000010B	720			



UNIT WITH
FRONT UPRIGHT
ÖN AYAKLI ÜNİTE

BACK SHELF FOR DOUBLE SHELVING UNIT (WITH FRONT SIDE CUT)
İKİLİ ÖZEL REYON İÇİN ARKA RAF

Code / Kod	P	H	L	Description / Açıklama
5A00000102B	320		500	Suitable for 30x30 or 30x60 front upright. 30x30 ya da 30x60 ön dikmeye uygundur.
5A00000103B	320		700	
5A00000104B	320		900	
5A00000105B	320		1000	
5A00000106B	320		1250	
5A00000107B	320		1330	
5A00000108B	420		500	
5A00000109B	420		700	
5A00000110B	420		900	
5A00000111B	420		1000	
5A00000112B	420		1250	
5A00000113B	420		1330	
5A00000114B	520		500	
5A00000115B	520		700	
5A00000116B	520		900	
5A00000117B	520		1000	
5A00000118B	520		1250	
5A00000119B	520		1330	
5A00000120B	620		500	
5A00000121B	620		700	
5A00000122B	620		900	
5A00000123B	620		1000	
5A00000124B	620		1250	
5A00000125B	620		1330	
5A00000126B	720		500	
5A00000127B	720		700	
5A00000128B	720		900	
5A00000129B	720		1000	
5A00000130B	720		1250	
5A00000131B	720		1330	

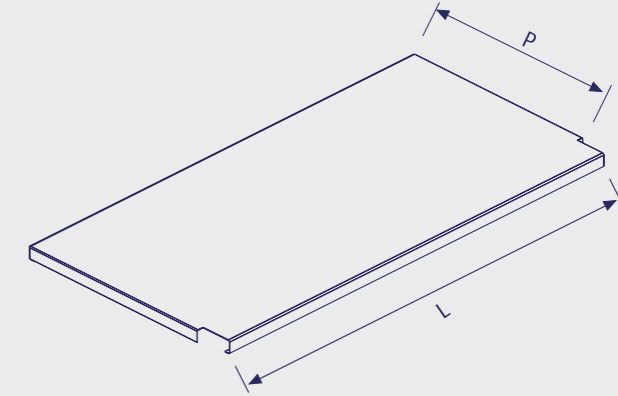

SHELF
RAF

Code / Kod	P	H	L	Description / Açıklama
5A00000036B	300		500*	*300x500 & 300x700 and 300x900 mm shelves are without support
5A00000039B	300		700*	
5A00000043B	300		900*	*300x500 300x700 ve 300x900 mm raflar takviyesizdir.
5A00000045B	300		1000	
5A00000047B	300		1250	
5A00000048B	300		1330	

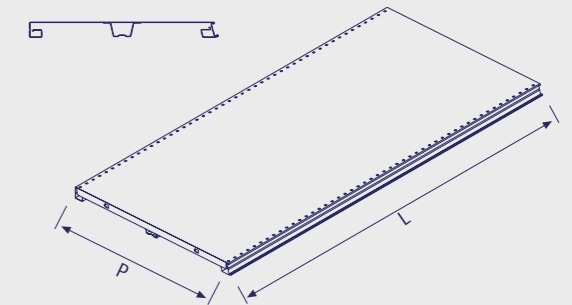



UNIT WITH
FRONT UPRIGHT
ÖN AYAKLI ÜNİTE

SHELF
RAF

Code / Kod	P	H	L	Description / Açıklama
5A0000051B	400		500	
5A0000055B	400		700	
5A0000060B	400		900	
5A0000062B	400		1000	
5A0000065B	400		1250	
5A0000066B	400		1330	

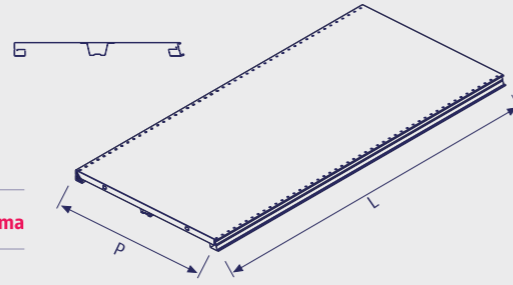

SHELF
RAF

Code / Kod	P	H	L	Description / Açıklama
5A0000067B	500		500	
5A0000069B	500		700	
5A0000071B	500		900	
5A0000072B	500		1000	
5A0000074B	500		1250	
5A0000075B	500		1330	

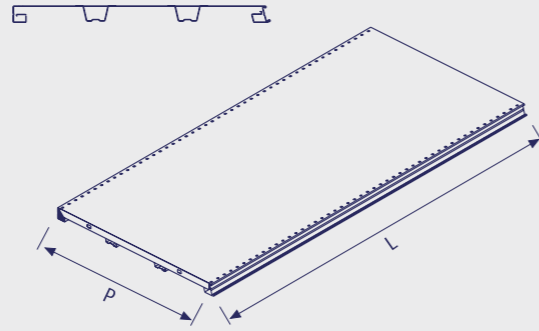

SHELF
RAF

Code / Kod	P	H	L	Description / Açıklama
5A0000076B	600		500	
5A0000078B	600		700	
5A0000079B	600		900	
5A0000080B	600		1000	
5A0000083B	600		1250	
5A0000084B	600		1330	

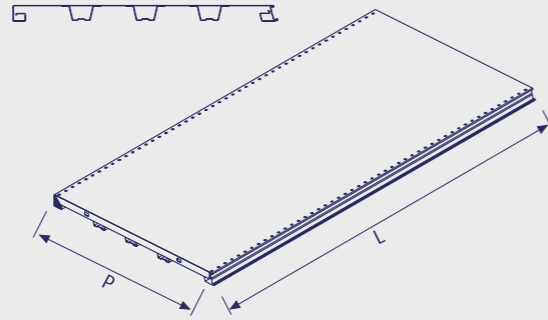

SHELF
RAF

Code / Kod	P	H	L	Description / Açıklama
5A0000085B	700		500	
5A0000086B	700		700	
5A0000087B	700		900	
5A0000088B	700		1000	
5A0000089B	700		1250	
5A0000090B	700		1330	

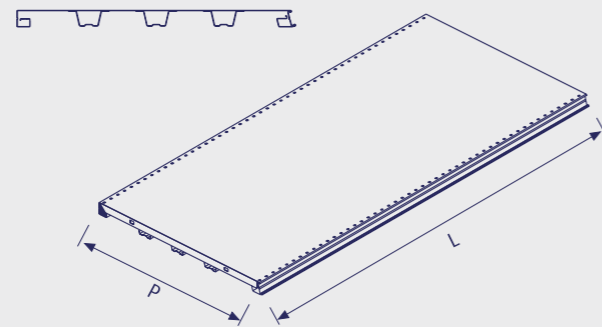

PLAIN BACK PANEL
DÜZ ARKA PANO

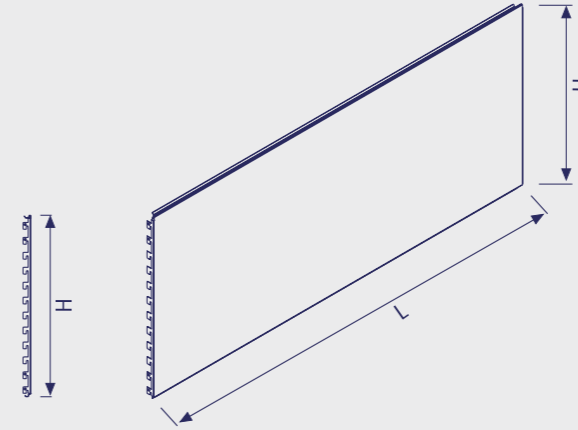

Code / Kod	P	H	L	Description / Açıklama
4A0000001B		420	500	
4A0000003B		420	700	
4A0000005B		420	900	
4A0000006B		420	1000	
4A0000008B		420	1250	
4A0000009B		420	1330	



UNIT WITH
FRONT UPRIGHT
ÖN AYAKLI ÜNİTE

FRONT PANEL
ALT ÖN PANEL

Code / Kod	P	H	L	Description / Açıklama
10A0000001B		100	500	
10A0000003B		100	700	
10A0000005B		100	900	
10A0000006B		100	1000	
10A0000008B		100	1250	
10A0000009B		100	1330	

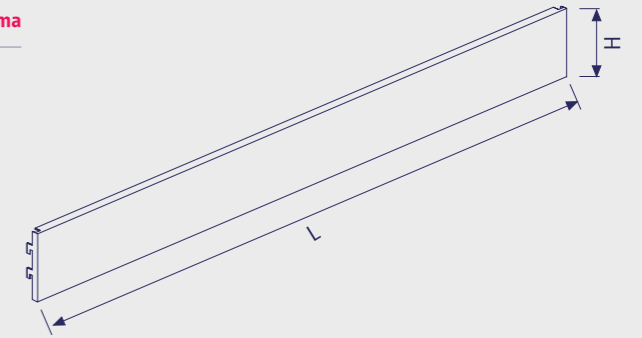

FRONT PANEL FOR FRONT UPRIGHT
ÖN DİKME İÇİN ALT ÖN PANEL

Code / Kod	P	H	L	Description / Açıklama
10A0000046B		100	500	
10A0000047B		100	700	
10A0000048B		100	900	
10A0000049B		100	1000	
10A0000050B		100	1250	
10A0000051B		100	1330	

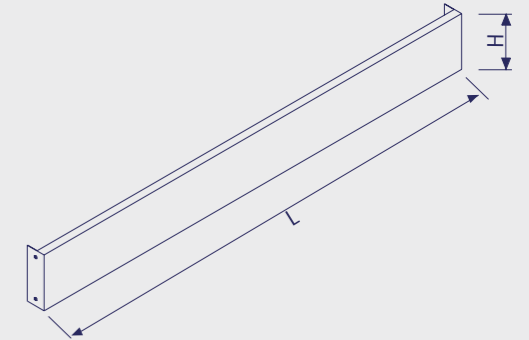

B

OVAL GONDOLA OVAL GONDOLBAŞI

02

ROUNDED GONDOLA HEAD UNIT YUVARLAK GONDOLBAŞI ÜNİTESİ

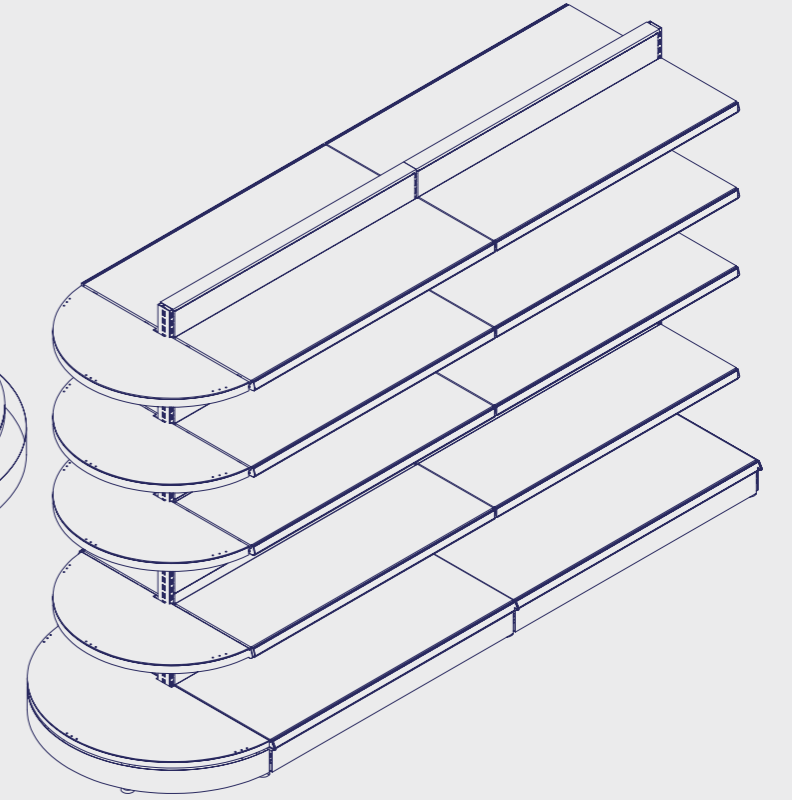
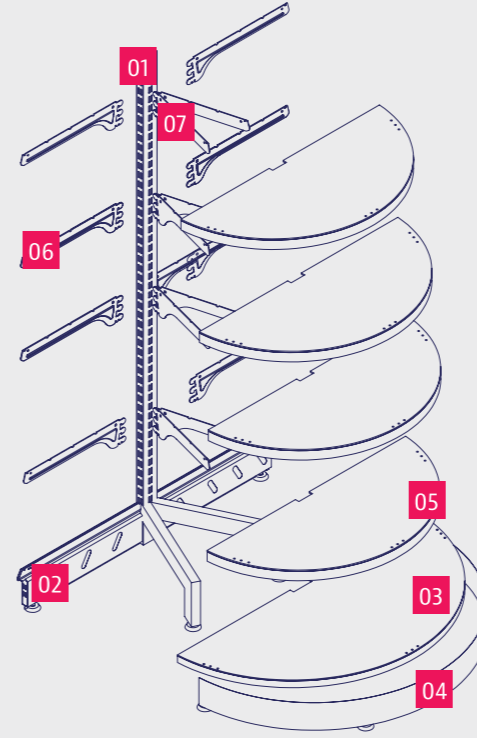

01
Upright for Rounded Gondola Head 30x80
Yuvarlak Gondolbaşı Dikmesi 30x80

02
Base Leg
Geçme Ayak

03
Rounded Base Shelf
Yuvarlak Gondolbaşı Taban Rafı

04
Rounded Base Front Panel
Yuvarlak Alt Ön Panel

05
Rounded Shelf
Yuvarlak Gondolbaşı Rafı

06
Bracket
Konsol

07
Middle Bracket for Rounded Shelf
Yuvarlak Gondolbaşı İçin Orta Konsol



OVAL
GONDOLA
OVAL GONDOLBAŞI



**OVAL
GONDOLA
OVAL GONDOLBAŞI**

ROUNDED GONDOLA HEAD WELDED UPRIGHT 30x80
OVAL GONDOLBAŞI KAYNAKLI AYAK 30x80

Code / Kod	P	H	L	Description / Açıklama
3Y00000001B	400	1010		With 3 side hole
3Y00000003B	400	1220		3 tarafı delikli
3Y00000005B	400	1430		
3Y00000007B	400	1640		
3Y00000009B	400	1850		
3Y00000011B	400	2060		
3Y00000013B	400	2270		
3Y00000002B	500	1010		With 3 side hole
3Y00000004B	500	1220		3 tarafı delikli
3Y00000006B	500	1430		
3Y00000008B	500	1640		
3Y00000010B	500	1850		
3Y00000012B	500	2060		
3Y00000014B	500	2270		

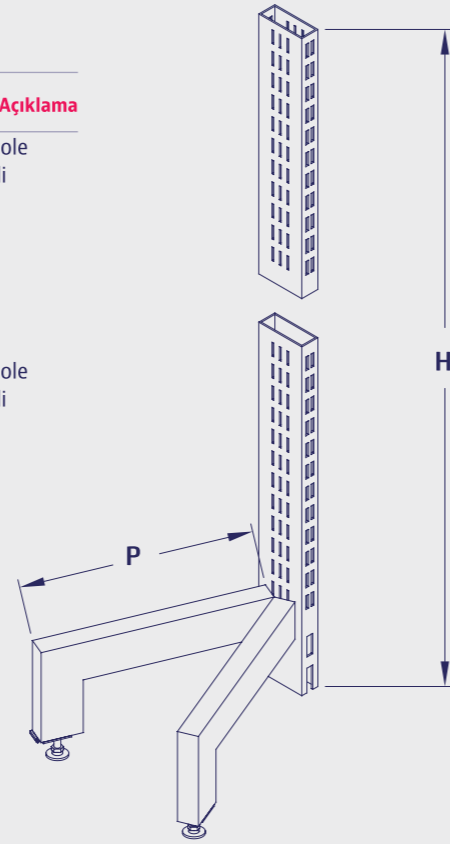

**BASE LEG
GEÇME AYAK**

Code / Kod	P	H	L	Description / Açıklama
2A00000006B	400	135		* P: 600
2A00000007B	500	135		base legs will be welded to upright.

* P: 600
geçme ayaklar dikmeye kaynaklı olacaktır.

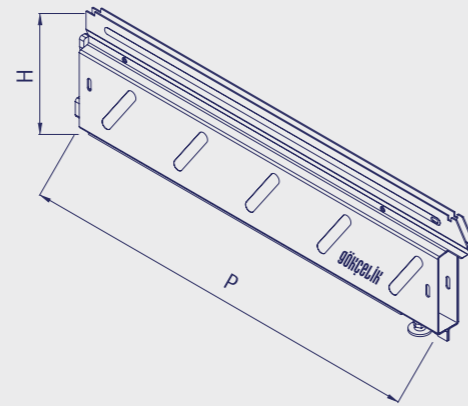

ROUNDED BASE SHELF (FOR 30x80 UPRIGHT)
OVAL GONDOLBAŞI TABAN RAFI (30x80 DİKME İÇİN)

Code / Kod	P	H	L	Description / Açıklama
5D00000004B	400		880	
5D00000005B	500		1080	

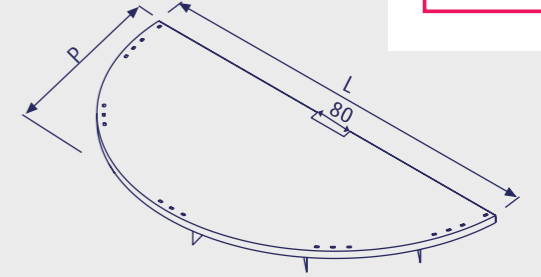

ROUNDED BASE FRONT PANEL
OVAL ALT ÖN PANEL

Code / Kod	P	H	L	Description / Açıklama
10A00000033B	400	135		
10A00000034B	500	135		

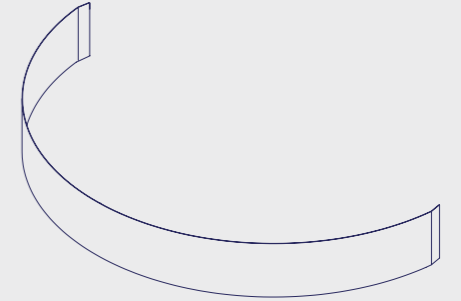

ROUNDED SHELF (FOR 30x80 UPRIGHT)
OVAL RAF (30x80 DİKME İÇİN)

Code / Kod	P	H	L	Description / Açıklama
5D00000008B	300	680		2x300 mm standard bracket / Standart konsol
5D00000009B	400	880		2x200 mm middle bracket / Orta konsol
5D00000010B	500	1080		2x400 mm standard bracket / Standart konsol 2x300 mm middle bracket / Orta konsol 2x500 mm standard bracket / Standart konsol 2x400 mm middle bracket / Orta konsol

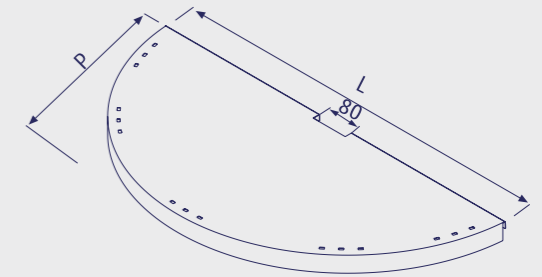



**OVAL
GONDOLA**
OVAL GONDOLBAŞI

**BRACKET
KONSOL**

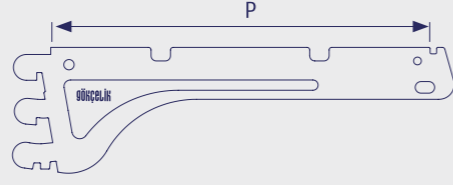

Code / Kod	P	H	L	Description / Açıklama
6A00000004B	300			
6A00000005B	400			

**BRACKET
KONSOL**

Code / Kod	P	H	L	Description / Açıklama
6A00000006B	500			

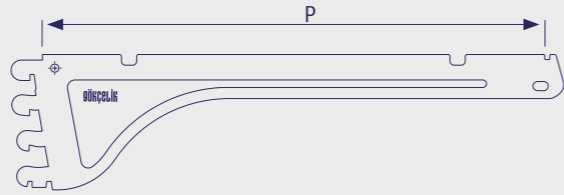

**BRACKET
KONSOL**

Code / Kod	P	H	L	Description / Açıklama
6A00000007B	600			

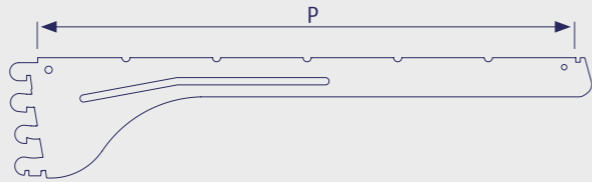

MIDDLE BRACKET FOR ROUNDED SHELF
YUVARLAK GONDOLBAŞI İÇİN ORTA KONSOL

Code / Kod	P	H	L	Description / Açıklama
6F00000002B	200			
6F00000004B	300			
6F00000005B	400			
6F00000006B	500			

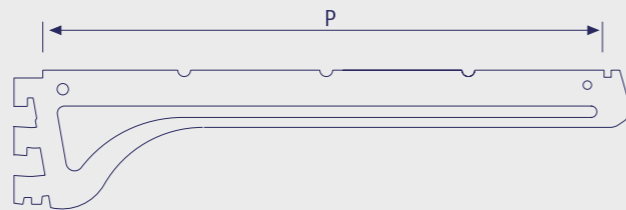

02

**WIRE SHELVING
SYSTEMS**
TEL RAF SİSTEMLERİ



**WIRE SHELVING
SYSTEMS**
TEL RAF
SİSTEMLERİ

WIRE ROUNDED HEAD UNIT
TEL YUVARLAK GONDOLBAŞI REYONU

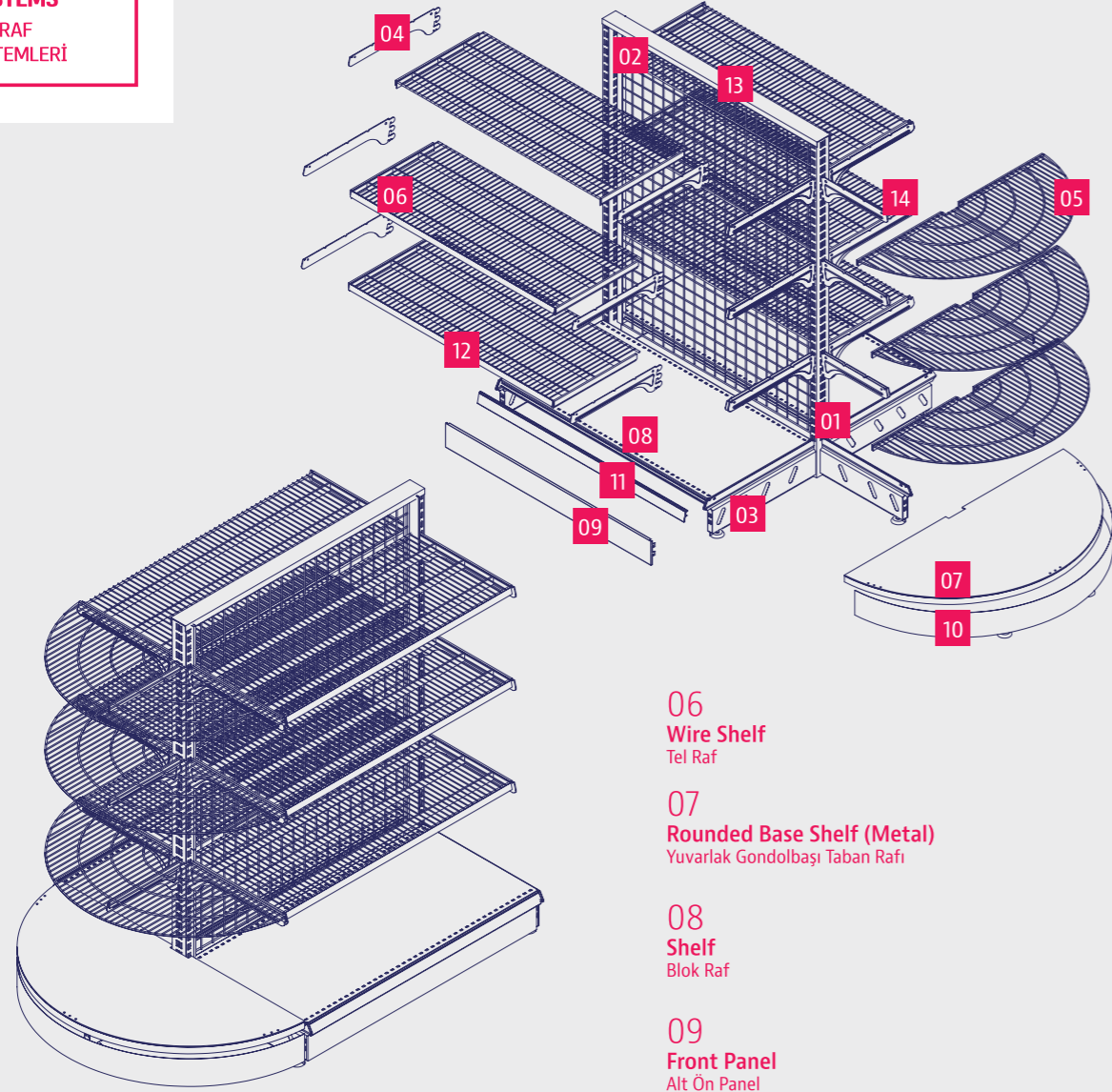

06
Wire Shelf
Tel Raf

07
Rounded Base Shelf (Metal)
Yuvarlak Gondolbaşı Taban Rafı

08
Shelf
Blok Raf

09
Front Panel
Alt Ön Panel

01
Upright for Rounded Gondola Head Unit 30x80
Yuvarlak Gondolbaşı Dikmesi 30x80

02
Wire Back Panel
Tel Arka Pano

03
Base Leg
Geçme Ayak

04
Bracket
Konsol

05
Rounded Wire Shelf
Yuvarlak Gondolbaşı Tel Raf

10
Rounded Base Front Panel
Yuvarlak Alt Ön Panel

11
Label Holder
Raf Etiketliği

12
Label Holder for Wire Shelf
Tel Raf Etiketliği

13
Top Cover for Gondola
Orta Reyon Kapağı

14
Middle Bracket for Rounded Shelf
Yuvarlak Gondolbaşı İçin Orta Konsol

WIRE WALL UNIT
TEL DUVAR REYONU

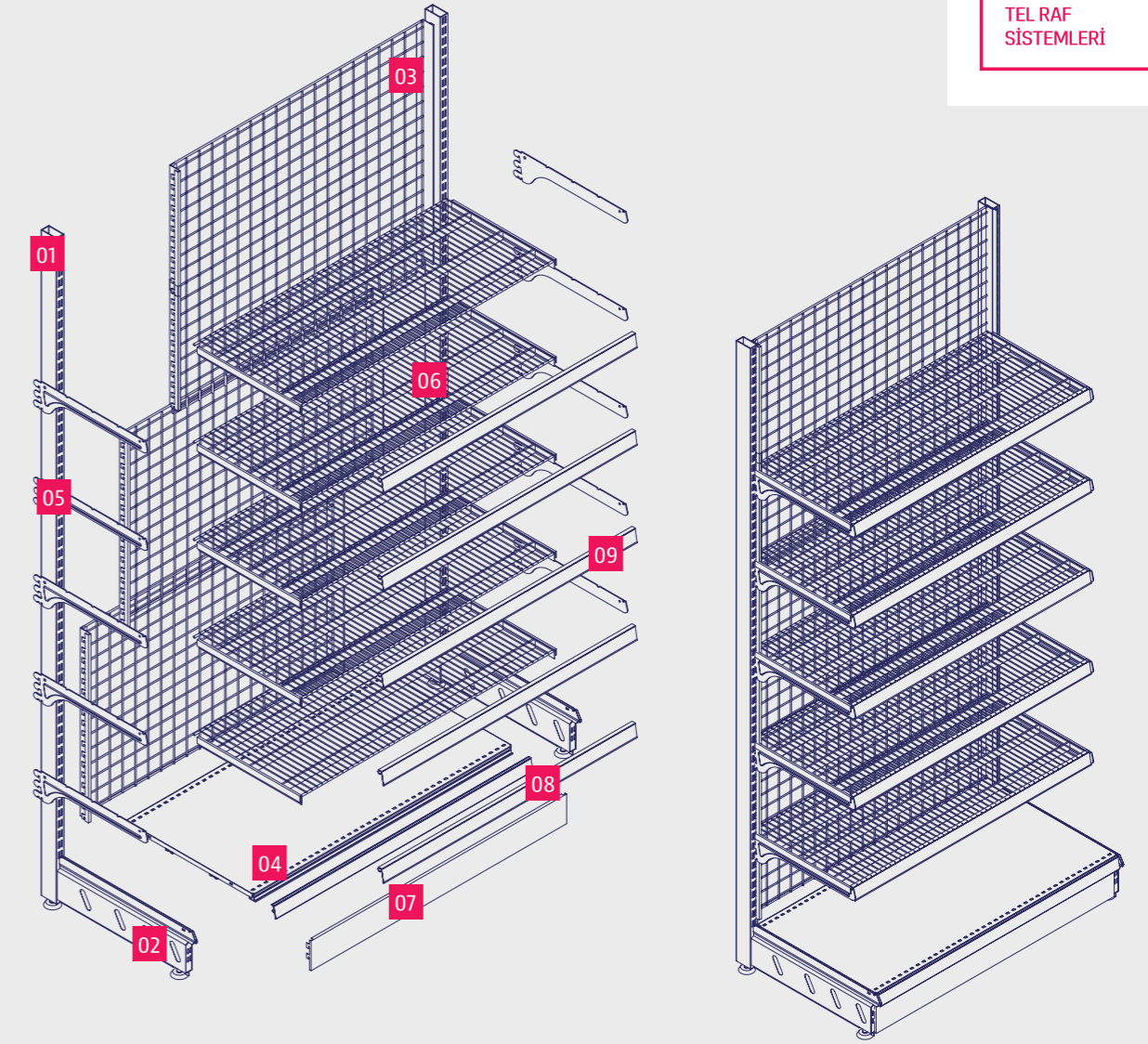

01
Upright
Dikme

02
Base Leg
Geçme Ayak

03
Wire Back Panel
Tel Arka Pano

04
Shelf
Blok Raf

05
Bracket
Konsol

06
Wire Shelf
Tel Raf

07
Front Panel
Alt Ön Panel

08
Label Holder
Raf Etiketliği

09
Label Holder for Wire Shelf
Tel Raf Etiketliği



**WIRE SHELVING
SYSTEMS**
TEL RAF
SİSTEMLERİ



**WIRE SHELVING
SYSTEMS**
TEL RAF
SİSTEMLERİ

SYSTEM 225 SAMPLE LAYOUT
SİSTEM 225 ÖRNEK YERLEŞİM PLANI

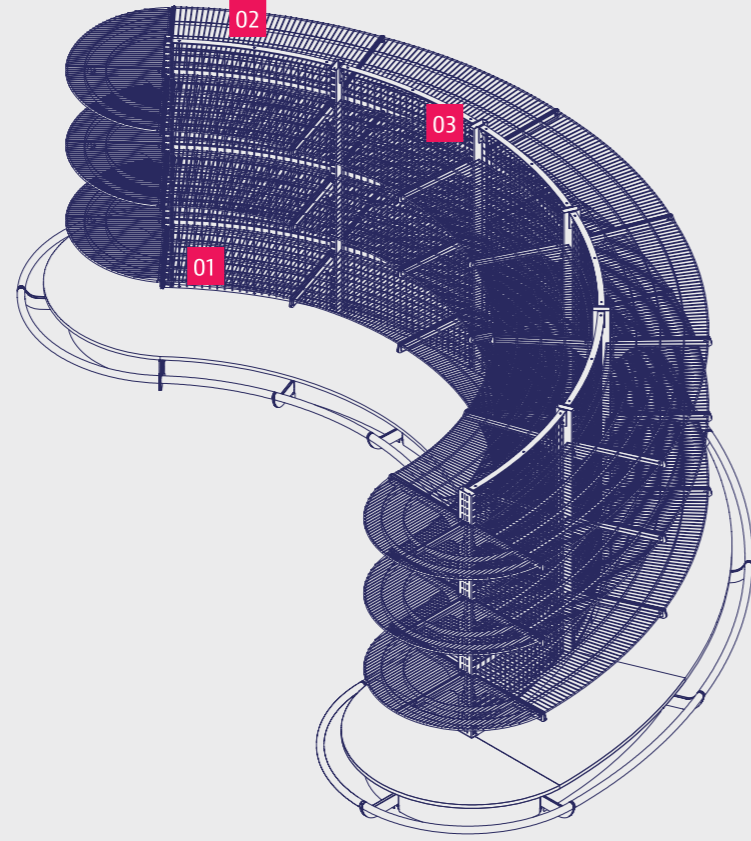

01
System 225
Wire Shelf Internal Corner

02
System 225
Wire Shelf External Corner

03
System 225
Wire Back Panel Internal Corner

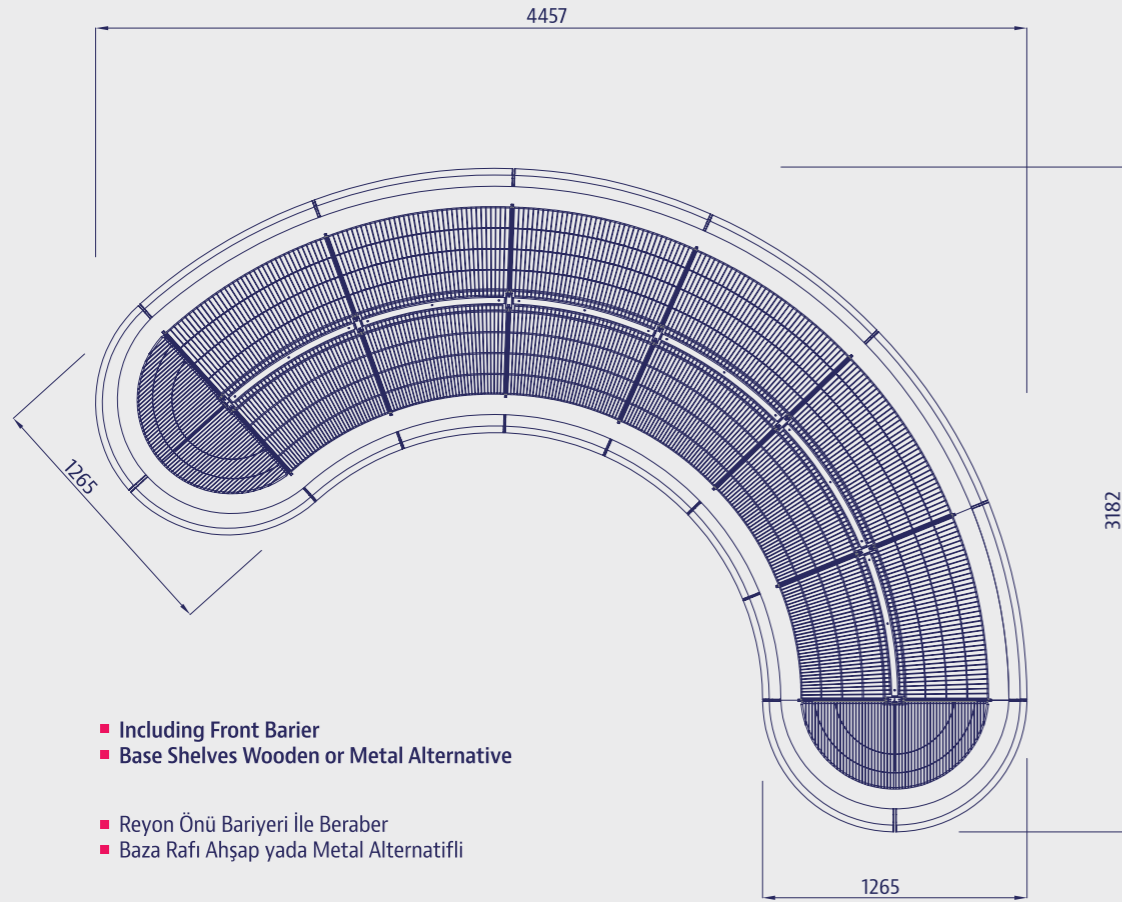

- Including Front Barrier
- Base Shelves Wooden or Metal Alternative

- Reyon Önü Bariyeri ile Beraber
- Baza Rafı Ahşap yada Metal Alternatifi



**WIRE SHELVING
SYSTEMS**
TEL RAF
SİSTEMLERİ

SYSTEM 225 INTERNAL CORNER SAMPLE LAYOUT
SİSTEM 225 İÇ KÖŞE ÖRNEK YERLEŞİM PLANI

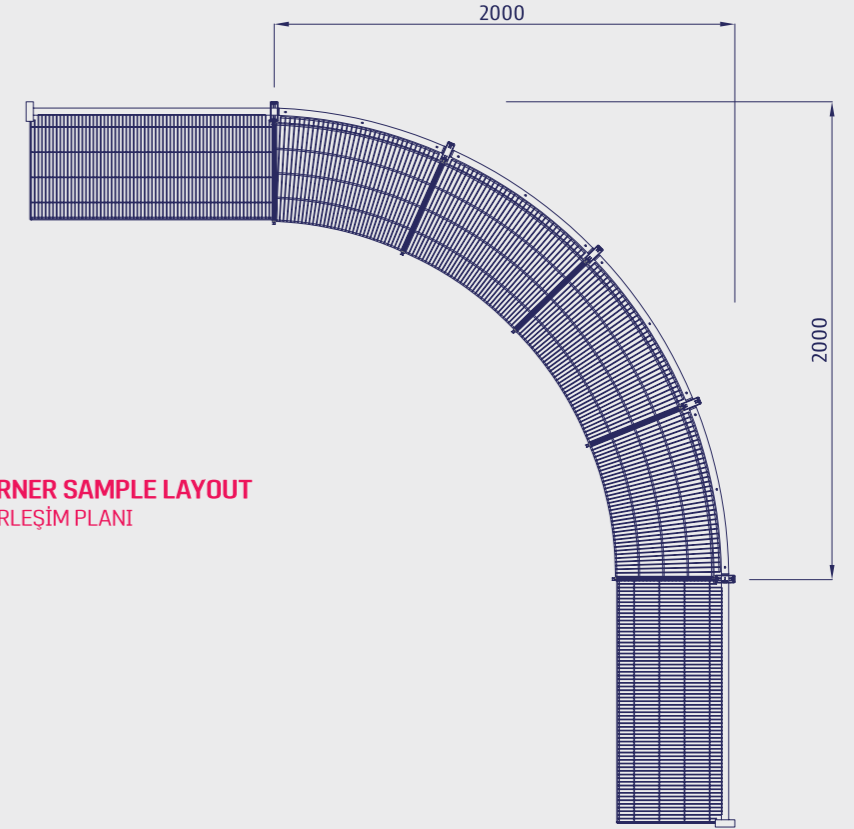

SYSTEM 225 EXTERNAL CORNER SAMPLE LAYOUT
SİSTEM 225 DIŞ KÖŞE ÖRNEK YERLEŞİM PLANI

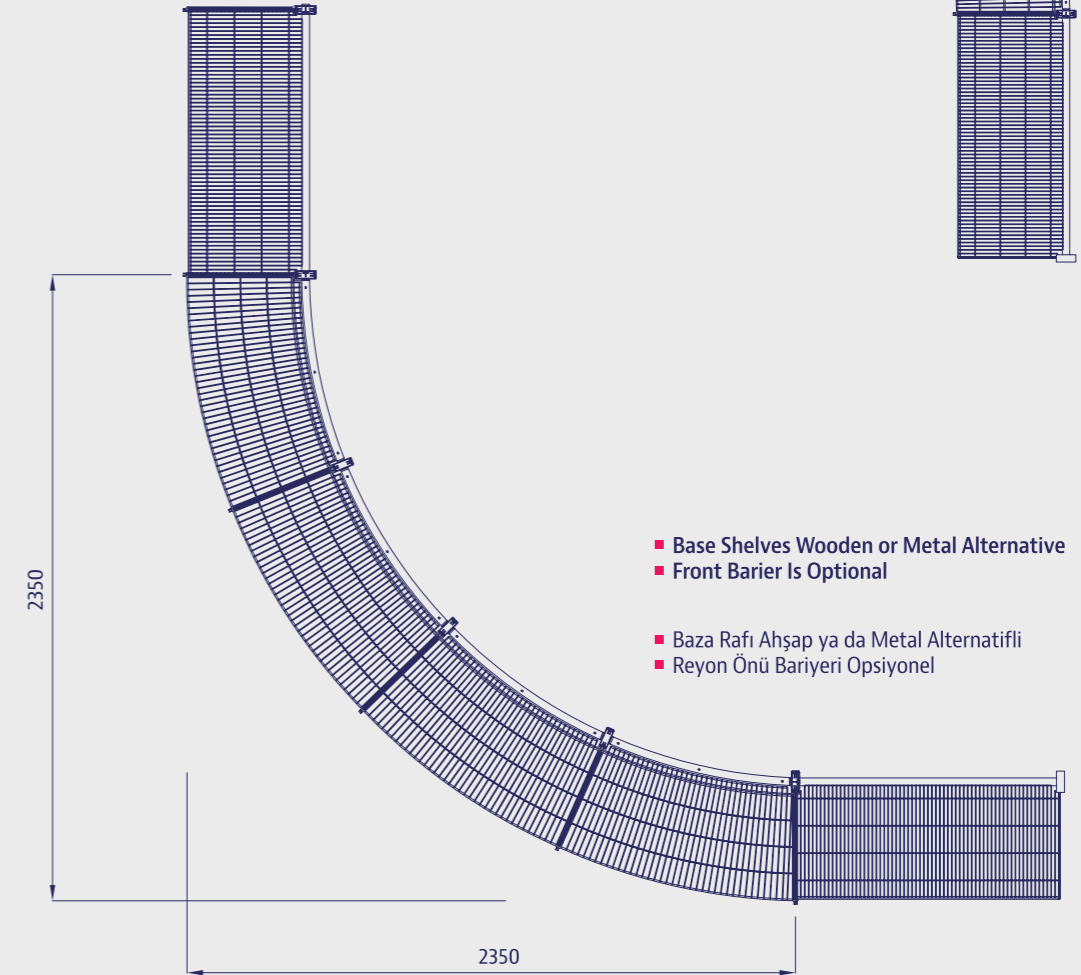

- Base Shelves Wooden or Metal Alternative
- Front Barrier Is Optional

- Baza Rafı Ahşap ya da Metal Alternatifi
- Reyon Önü Bariyeri Opsiyonel



**WIRE SHELVING
SYSTEMS**
TEL RAF
SİSTEMLERİ

**SYSTEM 450 EXTERNAL
CORNER SAMPLE LAYOUT**
SİSTEM 450 DIŞ KÖŞE ÖRNEK
YERLEŞİM PLANI

**SYSTEM 450 INTERNAL
CORNER SAMPLE LAYOUT**
SİSTEM 450 İÇ KÖŞE ÖRNEK
YERLEŞİM PLANI

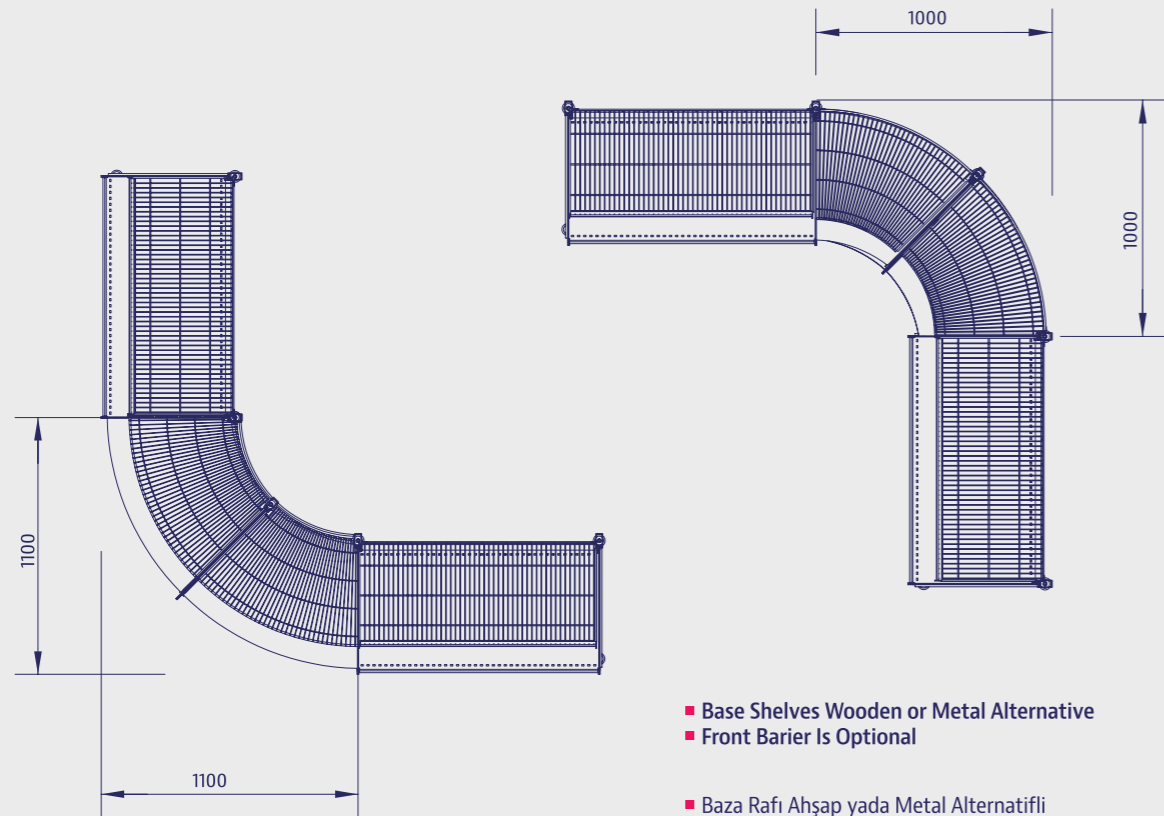
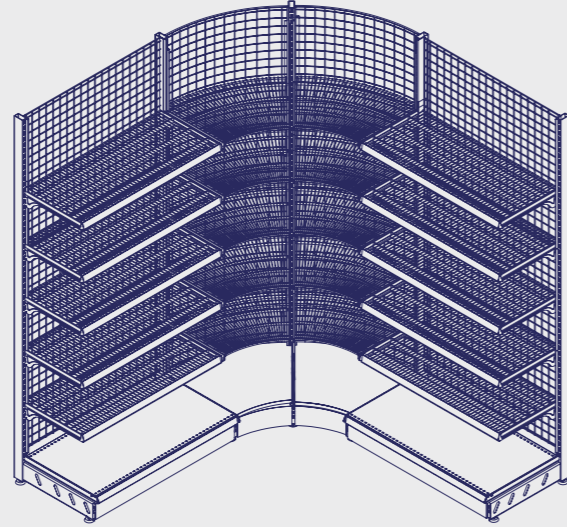
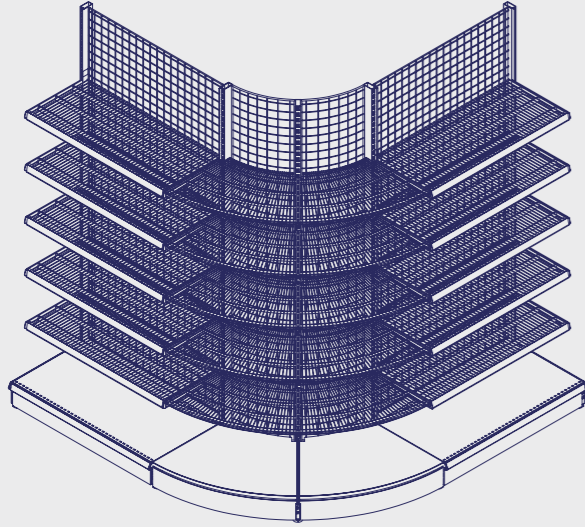

- Base Shelves Wooden or Metal Alternative
- Front Barrier Is Optional

- Baza Rafı Ahşap yada Metal Alternatifli
- Reyon Önü Bariyeri Opsiyonel



**WIRE SHELVING
SYSTEMS**
TEL RAF
SİSTEMLERİ

UPRIGHT (30x80 BOX PROFILE)
30x80 KUTU PROFİL

Code / Kod	P	H	L	Description / Açıklama
1C00000001B		1010		
1C00000002B		1220		
1C00000003B		1430		
1C00000004B		1640		
1C00000005B		1850		
1C00000006B		2060		
1C00000007B		2270		
1C00000008B		2480		
1C00000009B		2690		
1C00000010B		2900		

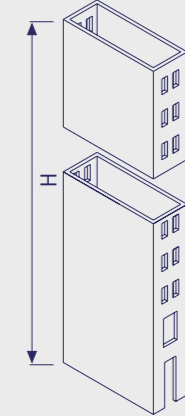
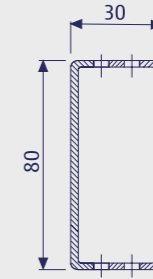

ROUNDED GONDOLA HEAD WELDED UPRIGHT 30x80
OVAL GONDOLBAŞI KAYNAKLI AYAK 30x80

Code / Kod	P	H	L	Description / Açıklama
3Y00000001B	400	1010		With 3 side hole 3 tarafı delikli
3Y00000003B	400	1220		
3Y00000005B	400	1430		
3Y00000007B	400	1640		
3Y00000009B	400	1850		
3Y00000011B	400	2060		
3Y00000013B	400	2270		
3Y00000002B	500	1010		With 3 side hole 3 tarafı delikli
3Y00000004B	500	1220		
3Y00000006B	500	1430		
3Y00000008B	500	1640		
3Y00000010B	500	1850		
3Y00000012B	500	2060		
3Y00000014B	500	2270		

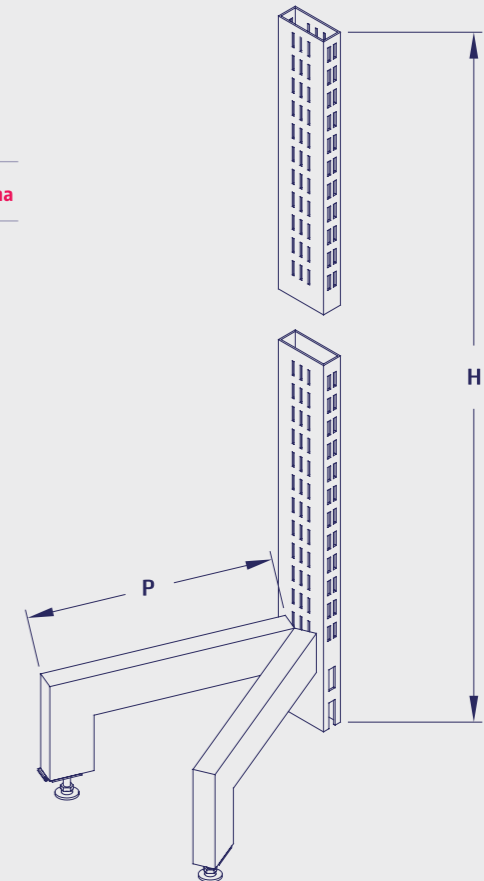



**WIRE SHELVING
SYSTEMS**
TEL RAF
SİSTEMLERİ

WIRE BACK PANEL (FOR 30x80 UPRIGHT)
TEL ARKA PANO (30x80 DİKME İÇİN)

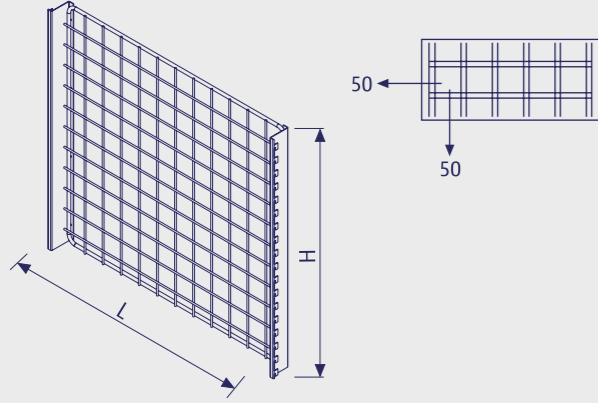

Code / Kod	P	H	L	Description / Açıklama
4V00000011B	630		500	Suitable to use with wire shelf Çerçeve tel 8 mm
4V00000012B	630		700	
4V00000013B	630		900	Ara tel 4 mm
4V00000014B	630		1000	Tel raflar ile kullanılır.
4V00000015B	630		1250	Frame 8mm wire
4V00000044B	630		1330	Separation 4 mm wire
4V00000016B	840		500	
4V00000017B	840		700	
4V00000018B	840		900	
4V00000019B	840		1000	
4V00000020B	840		1250	
4V00000045B	840		1330	

WIRE SHELF (FRONT 5x5 - FOR PLAIN BACK PANEL)
TEL RAF (ÖNÜ 5x5 - DÜZ ARKA PANO İÇİN)

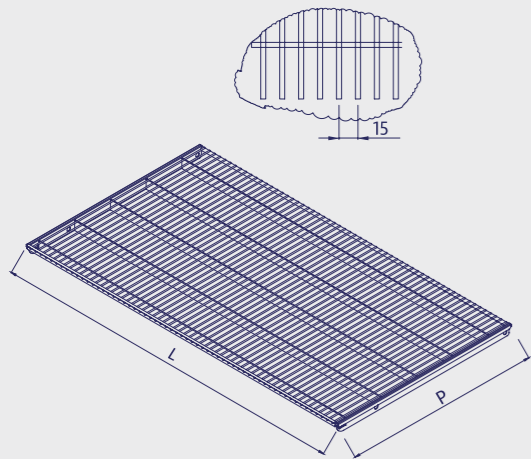

Code / Kod	P	H	L	Description / Açıklama
5H00000097B	300		500	Standart konsol ve önü 5x5 tel raf konsol ile kullanılır.
5H00000098B	300		700	
5H00000099B	300		900	Suitable use with standart bracket and front 5x5 wire shelf bracket
5H00000100B	300		1000	
5H00000101B	300		1250	
5H00000102B	400		500	
5H00000103B	400		700	
5H00000104B	400		900	
5H00000105B	400		1000	
5H00000106B	400		1250	
5H00000107B	500		500	
5H00000108B	500		700	
5H00000109B	500		900	
5H00000110B	500		1000	
5H00000111B	500		1250	
5H00000112B	600		500	
5H00000113B	600		700	
5H00000114B	600		900	
5H00000115B	600		1000	
5H00000116B	600		1250	

WIRE SHELF (FRONT 5x5 - FOR 30x80 UPRIGHT)
TEL RAF (ÖNÜ 5x5 - 30x80 DİKME İÇİN TEL ARKA PANO)

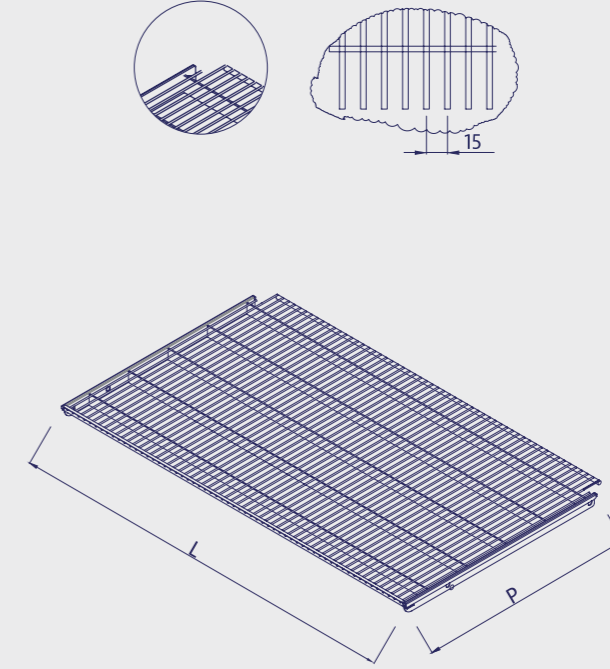

Code / Kod	P	H	L	Description / Açıklama
5H00000137B	300		500	Standart konsol ve önü 5x5 tel raf konsol ile kullanılır.
5H00000138B	300		700	
5H00000139B	300		900	Suitable use with standart wire shelf bracket and front 5x5 wire shelf bracket
5H00000140B	300		1000	
5H00000141B	300		1250	
5H00000142B	400		500	
5H00000143B	400		700	
5H00000144B	400		900	
5H00000145B	400		1000	
5H00000146B	400		1250	
5H00000147B	500		500	
5H00000148B	500		700	
5H00000149B	500		900	
5H00000150B	500		1000	
5H00000151B	500		1250	
5H00000152B	600		500	
5H00000153B	600		700	
5H00000154B	600		900	
5H00000155B	600		1000	
5H00000156B	600		1250	



**WIRE SHELVING
SYSTEMS**
TEL RAF
SİSTEMLERİ

ROUNDED WIRE SHELF (FRONT 5x5 - FOR 30x80 UPRIGHT)
OVAL TEL RAF (ÖNÜ 5x5 - 30x80 DİKME İÇİN)

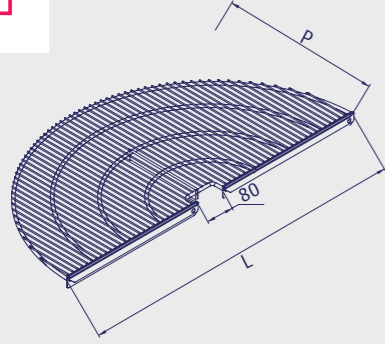

Code / Kod	P	H	L	Description / Açıklama
5H00000177U	300		680	
5H00000178U	400		880	
5H00000179U	500		1080	
5H00000180U	600		1280	

ROUNDED BASE SHELF (FOR 30x80 UPRIGHT)
OVAL GONDOLBAŞI TABAN RAFI (30x80 DİKME İÇİN)

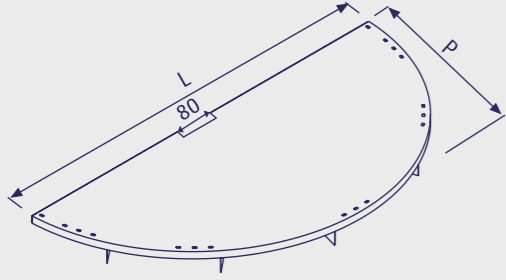

Code / Kod	P	H	L	Description / Açıklama
5D00000004B	400		880	
5D00000005B	500		1080	

ROUNDED BASE SHELF WOODEN 30 mm (FOR 30x80 UPRIGHT)
OVAL GONDOLBAŞI TABAN RAFI (30x80 DİKME İÇİN) AHŞAP 30 mm

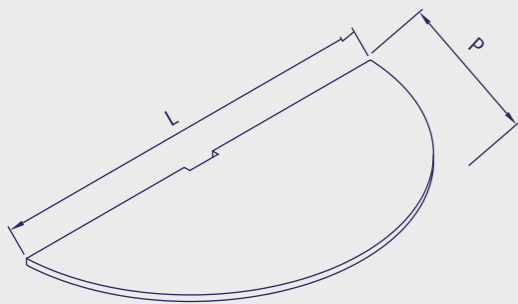

Code / Kod	P	H	L	Description / Açıklama
5D00000023M	300		680	
5D00000024M	400		880	
5D00000025M	500		1080	
5D00000026M	600		1280	



**WIRE SHELVING
SYSTEMS**
TEL RAF
SİSTEMLERİ

SYSTEM 225 WIRE BACK PANEL
SİSTEM 225 İÇİN TEL ARKA PANO

Code / Kod	P	H	L	Description / Açıklama
4V00000031B		840		İç ve Dış Köşe ortak kullanılmaktadır.
4V00000032B		630		

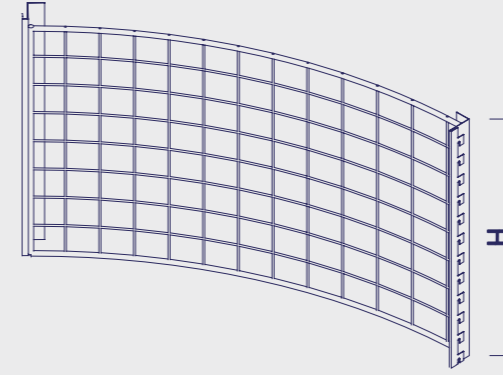

SYSTEM 450 WIRE BACK PANEL INTERNAL CORNER
SİSTEM 450 İÇİN İÇ KÖŞE TEL ARKA PANO

Code / Kod	P	H	L	Description / Açıklama
4V00000036B		630		
4V00000035B		840		

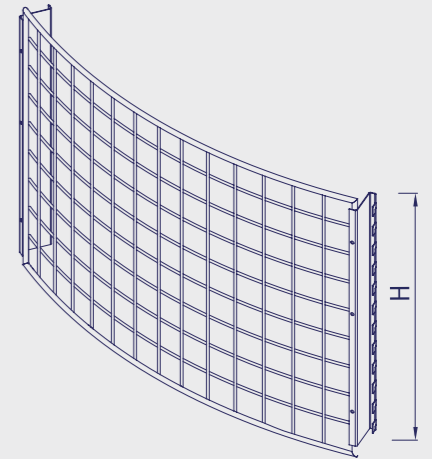

SYSTEM 450 WIRE BACK PANEL EXTERNAL CORNER
SİSTEM 450 İÇİN DIŞ KÖŞE TEL ARKA PANO

Code / Kod	P	H	L	Description / Açıklama
4V00000038B		630		
4V00000037B		840		



**WIRE SHELVING
SYSTEMS**
TEL RAF
SİSTEMLERİ

SYSTEM 225 WIRE SHELF INTERNAL CORNER
SİSTEM 225 İÇİN İÇ KÖŞE TEL RAF

Code / Kod	P	H	L	Description / Açıklama
5H00000185B	300			
5H00000186B	400			
5H00000187B	500			
5H00000188B	600			

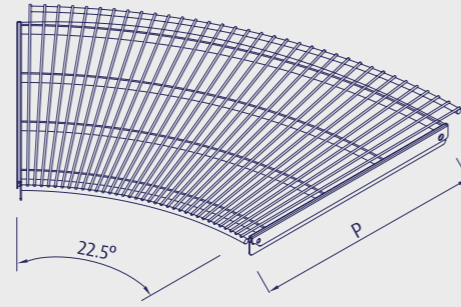

SYSTEM 225 BASE SHELF INTERNAL CORNER
SİSTEM 225 İÇİN İÇ KÖŞE TABAN RAFI

Code / Kod	P	H	L	Description / Açıklama
5B00000021B	300			Metal Shelf
5B00000022B	400			Metal Raf
5B00000023B	500			
5B00000024B	600			
5B00000036M	300			Wooden Shelf 30 mm
5B00000037M	400			Ahşap Raf 30 mm
5B00000038M	500			
5B00000039M	600			

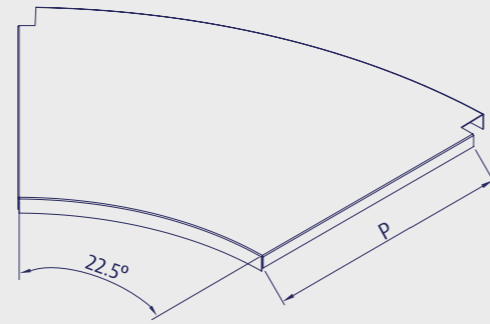

SYSTEM 225 WIRE SHELF EXTERNAL CORNER
SİSTEM 225 İÇİN DIŞ KÖŞE TEL RAF

Code / Kod	P	H	L	Description / Açıklama
5H00000189B	300			
5H00000190B	400			
5H00000191B	500			
5H00000192B	600			

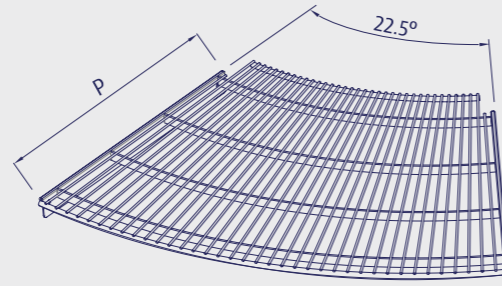

SYSTEM 225 BASE SHELF EXTERNAL CORNER
SİSTEM 225 İÇİN DIŞ KÖŞE TABAN RAFI

Code / Kod	P	H	L	Description / Açıklama
5C00000005B	300			Metal Shelf
5C00000006B	400			Metal Raf
5C00000007B	500			
5C00000008B	600			
5C00000017M	300			Wooden Shelf 30 mm
5C00000018M	400			Ahşap Raf 30 mm
5C00000019M	500			
5C00000020M	600			

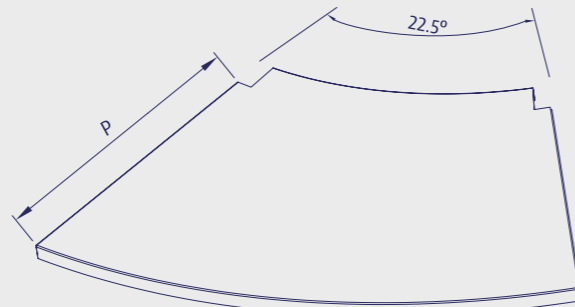

**WIRE SHELVING
SYSTEMS**
TEL RAF
SİSTEMLERİ

SYSTEM 450 WIRE SHELF INTERNAL CORNER
SİSTEM 450 İÇİN İÇ KÖŞE TEL RAF

Code / Kod	P	H	L	Description / Açıklama
5B00000025B	300			
5B00000026B	400			
5B00000027B	500			
5B00000028B	600			

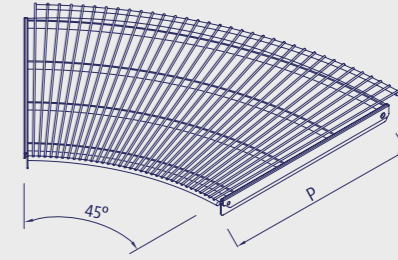

SYSTEM 450 BASE SHELF INTERNAL CORNER
SİSTEM 450 İÇİN İÇ KÖŞE TABAN RAFI

Code / Kod	P	H	L	Description / Açıklama
5B00000029B	300			Metal Shelf
5B00000030B	400			Metal Raf
5B00000031B	500			
5B00000032B	600			
5B00000040M	300			Wooden Shelf 30 mm
5B00000041M	400			Ahşap Raf 30 mm
5B00000042M	500			
5B00000043M	600			

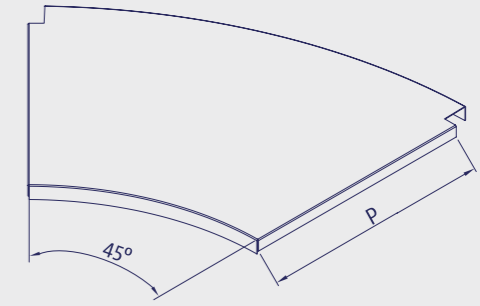

SYSTEM 450 WIRE SHELF EXTERNAL CORNER
SİSTEM 450 İÇİN DIŞ KÖŞE TEL RAF

Code / Kod	P	H	L	Description / Açıklama
5C00000009B	300			
5C00000010B	400			
5C00000011B	500			
5C00000012B	600			

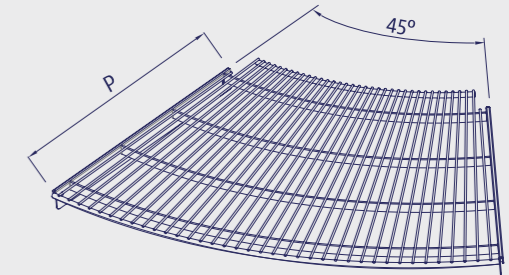

SYSTEM 450 WIRE SHELF EXTERNAL CORNER
SİSTEM 450 İÇİN DIŞ KÖŞE TEL RAF

Code / Kod	P	H	L	Description / Açıklama
5C00000013B	300			Metal Shelf
5C00000014B	400			Metal Raf
5C00000015B	500			
5C00000016B	600			
5C00000021M	300			Wooden Shelf 30 mm
5C00000022M	400			Ahşap Raf 30 mm
5C00000023M	500			
5C00000024M	600			

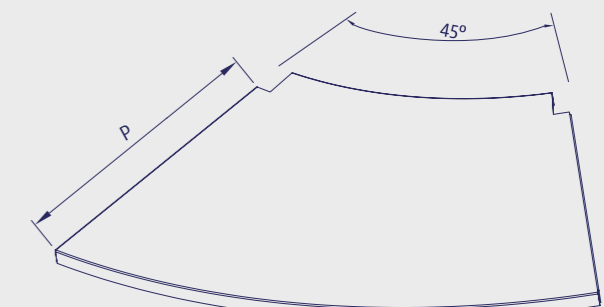



**WIRE SHELVING
SYSTEMS**
TEL RAF
SİSTEMLERİ

**BRACKET
KONSOL**

Code / Kod	P	H	L	Description / Açıklama
6A0000004B	300			
6A0000005B	400			

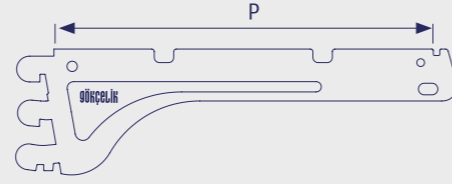

**BRACKET
KONSOL**

Code / Kod	P	H	L	Description / Açıklama
6A0000006B	500			

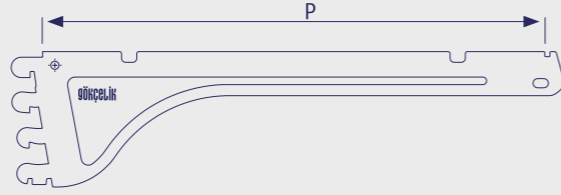

**BRACKET
KONSOL**

Code / Kod	P	H	L	Description / Açıklama
6A0000007B	600			

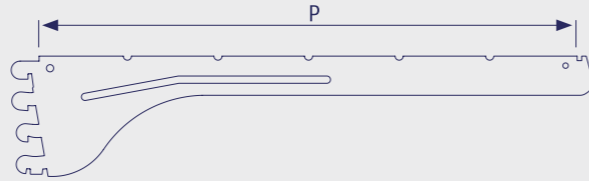

MIDDLE BRACKET FOR ROUNDED SHELF
YUVARLAK GONDOLBAŞI İÇİN ORTA KONSOL

Code / Kod	P	H	L	Description / Açıklama
6F0000002B	200			
6F0000004B	300			
6F0000005B	400			
6F0000006B	500			

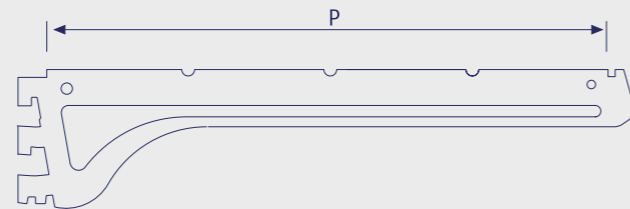

ROUNDED BASE FRONT PANEL
OVAL ALT ÖN PANEL

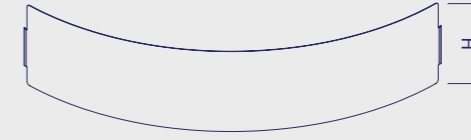

Code / Kod	P	H	L	Description / Açıklama
10A0000033B	400	135		
10A0000034B	500	135		

SYSTEM 225 FRONT PANEL INTERNAL CORNER
SİSTEM 225 İÇİN İÇ KÖŞE ALT ÖN PANEL

Code / Kod	P	H	L	Description / Açıklama
10A0000052B	300	135		
10A0000053B	400	135		
10A0000054B	500	135		

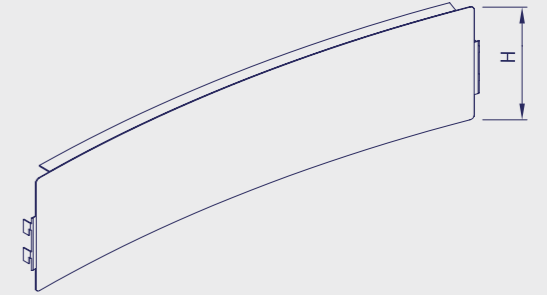

SYSTEM 450 FRONT PANEL INTERNAL CORNER
SİSTEM 450 İÇİN İÇ KÖŞE ALT ÖN PANEL

Code / Kod	P	H	L	Description / Açıklama
10A0000055B	300	135		
10A0000056B	400	135		
10A0000057B	500	135		

SYSTEM 225 FRONT PANEL EXTERNAL CORNER
SİSTEM 225 DIŞ KÖŞE ALT ÖN PANEL

Code / Kod	P	H	L	Description / Açıklama
10A0000058B	300	135		
10A0000059B	400	135		
10A0000060B	500	135		

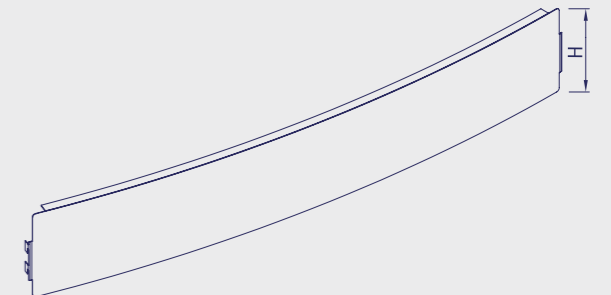

SYSTEM 450 FRONT PANEL EXTERNAL CORNER
SİSTEM 450 DIŞ KÖŞE ALT ÖN PANEL

Code / Kod	P	H	L	Description / Açıklama
10A0000061B	300	135		
10A0000062B	400	135		
10A0000063B	500	135		



WIRE SHELVING SYSTEMS

TEL RAF SİSTEMLERİ

ROUNDED FRONT BARRIER OVAL GONDOLBAŞI BARIYER

Code / Kod	P	H	L	Description / Açıklama
12H0000021N	300			* For Front Barrier, Metal part Will be Wlded in Front of Base Leg
12H0000018N	400			
12H0000020N	500			* Reyon önü bariyer için Geçme
12H0000022N	600			Ayağın önüne sac parçacı kaynatılacaktır.



SYSTEM 225 FRONT BARRIER INTERNAL CORNER SİSTEM 225 REYON ÖNÜ BARIYERİ İÇ KÖŞE

Code / Kod	P	H	L	Description / Açıklama
12H0000010N	300			* For Front Barrier, Metal part Will be Wlded in Front of Base Leg
12H0000011N	400			
12H0000012N	500			* Reyon önü bariyer için Geçme
12H0000013N	600			Ayağın önüne sac parçacı kaynatılacaktır.

SYSTEM 450 FRONT BARRIER INTERNAL CORNER SİSTEM 450 REYON ÖNÜ BARIYERİ İÇ KÖŞE

Code / Kod	P	H	L	Description / Açıklama
12H0000023N	300			* For Front Barrier, Metal part Will be Wlded in Front of Base Leg
12H0000024N	400			
12H0000025N	500			* Reyon önü bariyer için Geçme
12H0000026N	600			Ayağın önüne sac parçacı kaynatılacaktır.

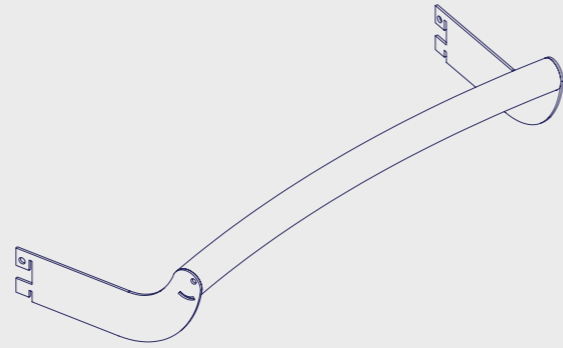

SYSTEM 225 FRONT BARRIER EXTERNAL CORNER SİSTEM 225 REYON ÖNÜ BARIYERİ DIŞ KÖŞE

Code / Kod	P	H	L	Description / Açıklama
12H0000014N	300			* For Front Barrier, Metal part Will be Wlded in Front of Base Leg
12H0000015N	400			
12H0000016N	500			* Reyon önü bariyer için Geçme
12H0000017N	600			Ayağın önüne sac parçacı kaynatılacaktır.

SYSTEM 450 FRONT BARRIER EXTERNAL CORNER SİSTEM 450 REYON ÖNÜ BARIYERİ DIŞ KÖŞE

Code / Kod	P	H	L	Description / Açıklama
12H0000027N	300			* For Front Barrier, Metal part Will be Wlded in Front of Base Leg
12H0000028N	400			
12H0000029N	500			* Reyon önü bariyer için Geçme
12H0000030N	600			Ayağın önüne sac parçacı kaynatılacaktır.

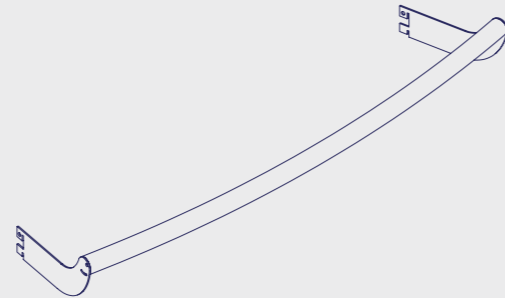

02

D

GONDOLA HEAD
SIDE UNIT

GONDOLBAŞI
YAN STAND



**GONDOLA HEAD
SIDE UNIT
GONDOLBAŞI
YAN STAND**

**GONDOLA HEAD SIDE UNIT
GONDOLBAŞI YAN STAND**

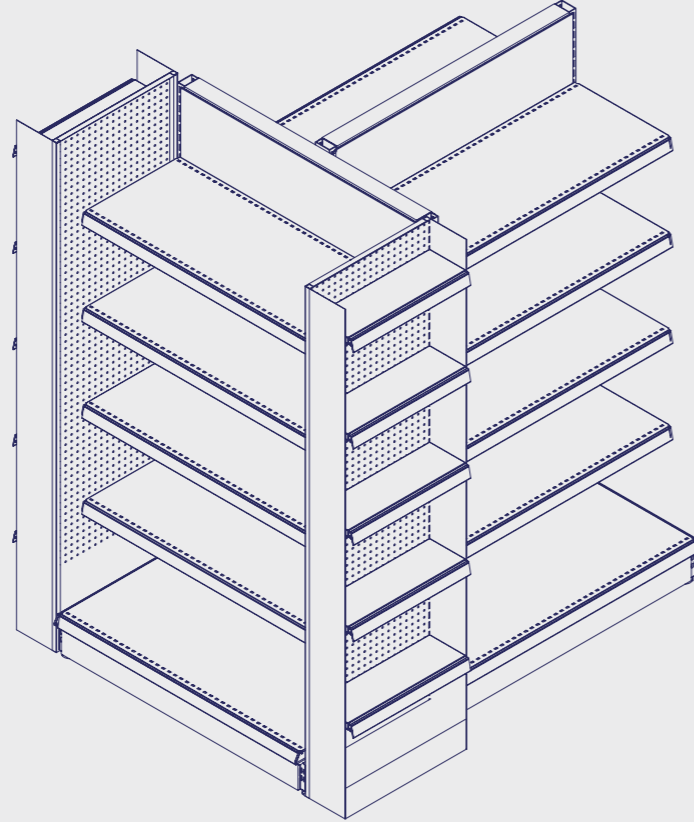
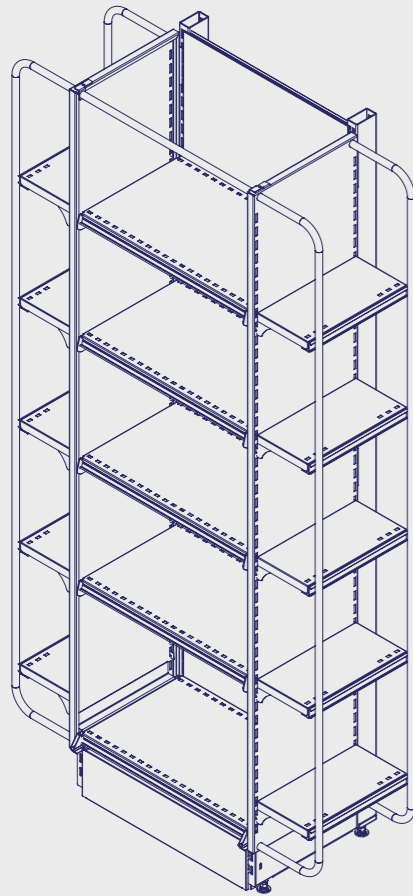
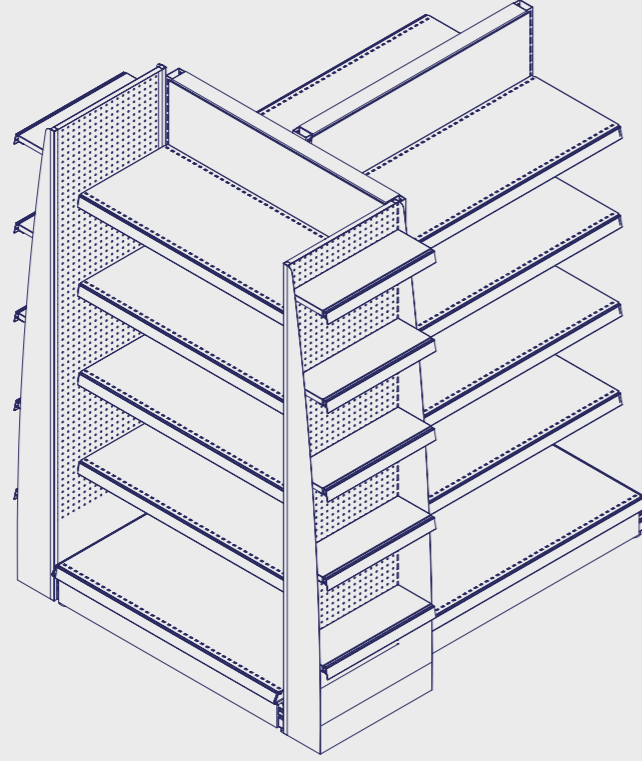

**GONDOLA HEAD
SIDE UNIT
GONDOLBAŞI
YAN STAND**

**GONDOLA HEAD SIDE UNIT
GONDOLBAŞI YAN STAND**

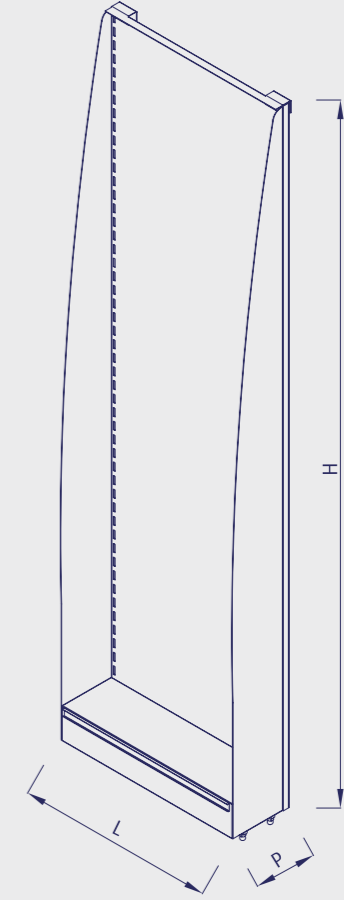
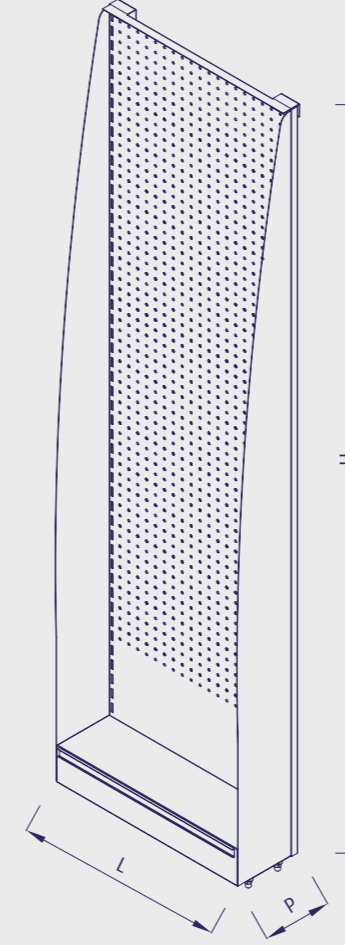

Code / Kod	P	H	L	Description / Açıklama
8A0000001B	150	1430	400	
8A0000006B	150	1430	500	
8A0000002B	150	1640	400	
8A0000007B	150	1640	500	
8A0000003B	150	1850	400	
8A0000008B	150	1850	500	
8A0000004B	150	2060	400	
8A0000009B	150	2060	500	
8A0000005B	150	2270	400	
8A0000010B	150	2270	500	
8A0000011B	200	1430	400	
8A0000016B	200	1430	500	
8A0000012B	200	1640	400	
8A0000017B	200	1640	500	
8A0000013B	200	1850	400	
8A0000018B	200	1850	500	
8A0000014B	200	2060	400	
8A0000019B	200	2060	500	
8A0000015B	200	2270	400	
8A0000020B	200	2270	500	

Code / Kod	P	H	L	Description / Açıklama
8A0000021B	150	1430	400	
8A0000026B	150	1430	500	
8A0000022B	150	1640	400	
8A0000027B	150	1640	500	
8A0000023B	150	1850	400	
8A0000028B	150	1850	500	
8A0000024B	150	2060	400	
8A0000029B	150	2060	500	
8A0000025B	150	2270	400	
8A0000030B	150	2270	500	
8A0000031B	200	1430	400	
8A0000036B	200	1430	500	
8A0000032B	200	1640	400	
8A0000037B	200	1640	500	
8A0000033B	200	1850	400	
8A0000038B	200	1850	500	
8A0000034B	200	2060	400	
8A0000039B	200	2060	500	
8A0000035B	200	2270	400	
8A0000040B	200	2270	500	



**GONDOLA HEAD
SIDE UNIT**
GONDOLBAŞI
YAN STAND

GONDOLA HEAD SIDE UNIT
GONDOLBAŞI YAN STAND

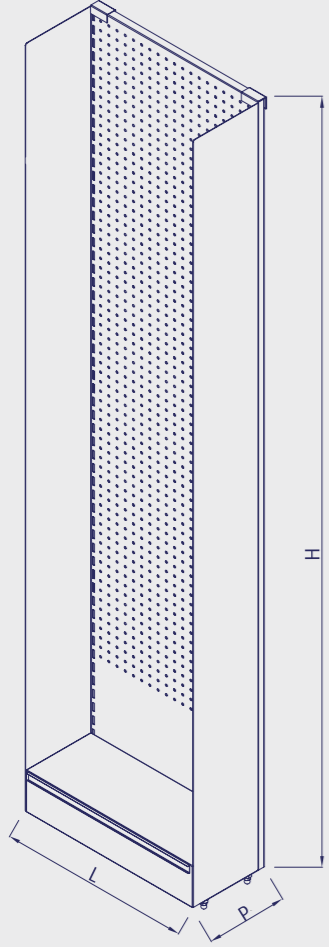

Code / Kod	P	H	L	Description / Açıklama
8A00000041B	150	1430	400	
8A00000046B	150	1430	500	
8A00000042B	150	1640	400	
8A00000047B	150	1640	500	
8A00000043B	150	1850	400	
8A00000048B	150	1850	500	
8A00000044B	150	2060	400	
8A00000049B	150	2060	500	
8A00000045B	150	2270	400	
8A00000050B	150	2270	500	

Code / Kod	P	H	L	Description / Açıklama
8A00000061B	150	1430	400	
8A00000066B	150	1430	500	
8A00000062B	150	1640	400	
8A00000067B	150	1640	500	
8A00000063B	150	1850	400	
8A00000068B	150	1850	500	
8A00000064B	150	2060	400	
8A00000069B	150	2060	500	
8A00000065B	150	2270	400	
8A00000070B	150	2270	500	



**GONDOLA HEAD
SIDE UNIT**
GONDOLBAŞI
YAN STAND

OPERA GONDOLA HEAD SIDE UNIT
OPERA GONDOLBAŞI YAN STAND

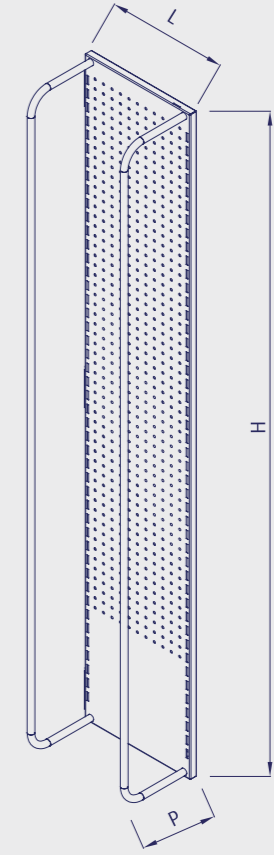
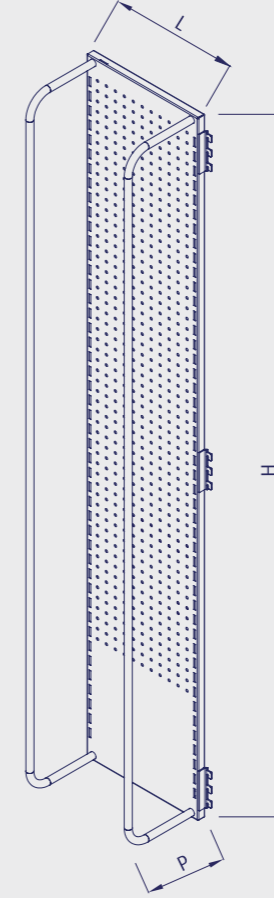

Code / Kod	P	H	L	Description / Açıklama
8A00000083.1B	180	1700	300	Sağ / Right

Code / Kod	P	H	L	Description / Açıklama
8A00000083.2B	180	1700	300	Sol / Left



**GONDOLA HEAD
SIDE UNIT
GONDOLBAŞI
YAN STAND**

**OPERA GONDOLA HEAD SIDE UNIT
OPERA GONDOLBAŞI YAN STAND**

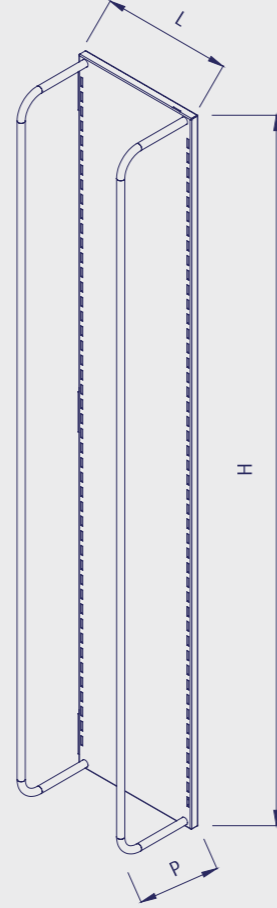
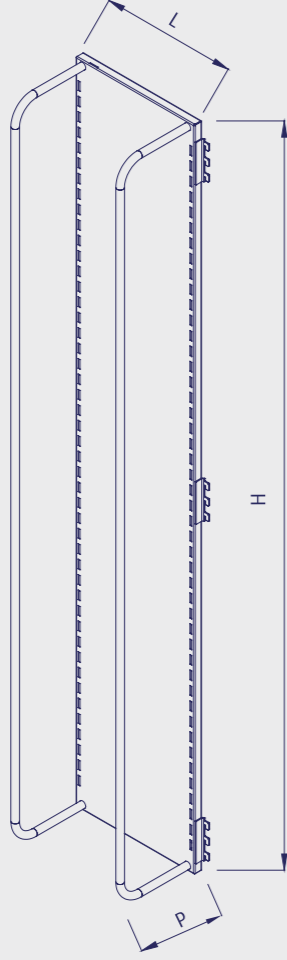

Code / Kod	P	H	L	Description / Açıklama
8A00000082.1B	180	1700	300	Sağ / Right

Code / Kod	P	H	L	Description / Açıklama
8A00000082.2B	180	1700	300	Sol / Left

**OPERA GONDOLA HEAD SIDE FIXING BEAM
OPERA GONDOL BAŞI YAN STAND ARA BAĞLANTI**

Code / Kod	P	H	L	Description / Açıklama
8A00000082.3B			500	
8A00000082.4B			700	
8A00000082.5B			900	
8A00000082.6B			1000	
8A00000082.7B			1250	
8A00000082.8B			1330	

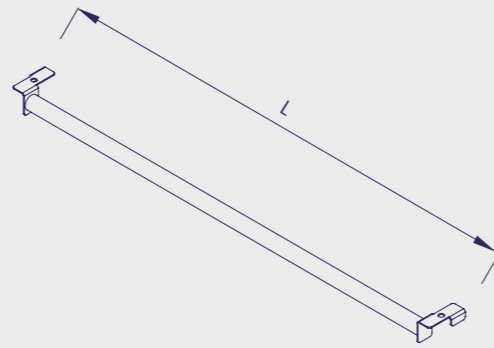

**GONDOLA HEAD
SIDE UNIT
GONDOLBAŞI
YAN STAND**

**SHELF WITH BRACKET
KENDİNDEN YANAKLI RAF**

Code / Kod	P	H	L	Description / Açıklama
5E00000002B	150		400	
5E00000003B	150		500	

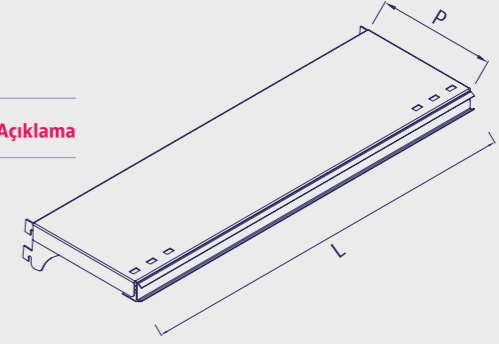

**SHELF
RAF**

Code / Kod	P	H	L	Description / Açıklama
5A00000012B	200		400	
5A00000013B	200		500	

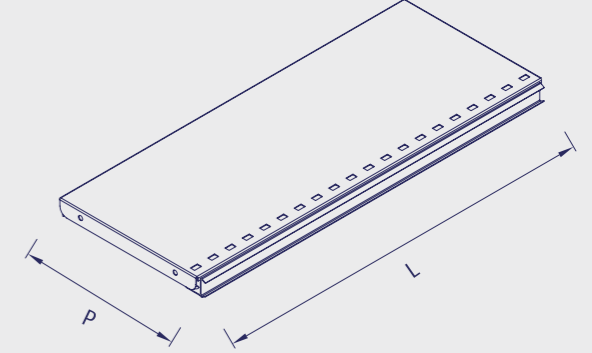

**BRACKET (BACK CUT)
KONSOL (ARKASI KESİK)**

Code / Kod	P	H	L	Description / Açıklama
6F00000002B	200			

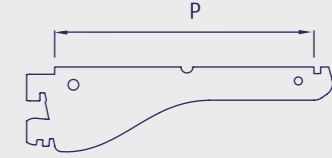

**FOOT SCREW
ROTİL CİVATA**

Code / Kod	P	H	L	Description / Açıklama
93000000014				

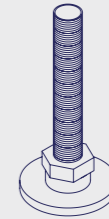

**FRONT GRILL
ÖN TEL**

Code / Kod	P	H	L	Description / Açıklama
11A0000001B		40	400	
11A0000002B		40	500	



E

ILLUMINATION
AYDINLATMA

02



ILLUMINATION
AYDINLATMA

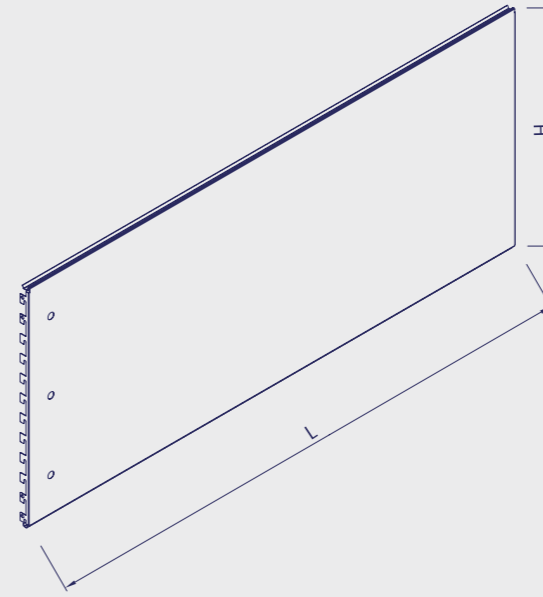

BACK PANEL WITH 3 SOCKET HOLES
DÜZ ARKA PANO 3 SOKET DELİKLİ

Code / Kod	P	H	L	Description / Açıklama
4K00000001B		420	500	
4K00000002B		420	700	
4K00000003B		420	900	
4K00000004B		420	1000	
4K00000005B		420	1250	
4K00000006B		420	1330	

BACK PANEL WITH 2 SOCKET HOLES
DÜZ ARKA PANO 2 SOKET DELİKLİ

Code / Kod	P	H	L	Description / Açıklama
4K00000007B		210	500	
4K00000008B		210	700	
4K00000009B		210	900	
4K00000010B		210	1000	
4K00000011B		210	1250	
4K00000012B		210	1330	

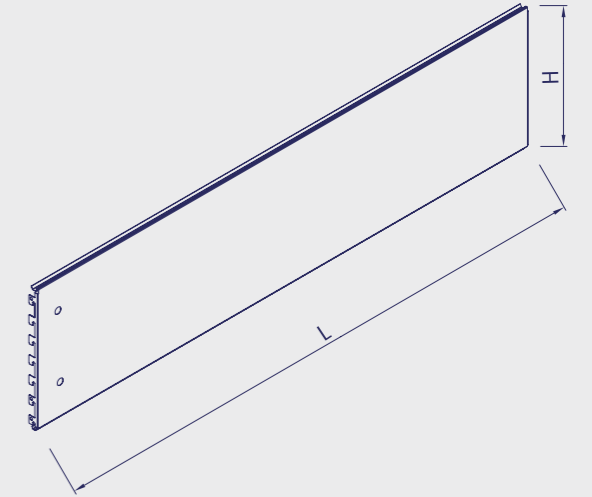

SOCKET FOR BACK PANEL
PANO SOKET ENERJİ KABLOSU

Code / Kod	P	H	L	Description / Açıklama
93000000195				White / Black Beyaz / Siyah AC 166 GEBU/3





ILLUMINATION
AYDINLATMA

CONNECTION CABLE FOR SHELF LIGHTING / 2 SIDES WITH SOCKET PANO SOKET RAF ALTI AYDINLATMA KABLOSU / 2 UCU SOKETLİ

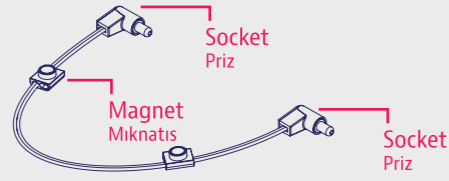

Code / Kod	Shelf Depth Raf Derinliği	Cable Dimension Kablo Ölçüsü	Color Alternatives Renk Alternatifleri	Description / Açıklama
93000000504	P: 200	250 mm	White / Black - Beyaz / Siyah	
93000000507	P: 300	350 mm	White / Black - Beyaz / Siyah	
93000000509	P: 400	450 mm	White / Black - Beyaz / Siyah	
93000000511	P: 500	550 mm	White / Black - Beyaz / Siyah	
93000000512	P: 600	650 mm	White / Black - Beyaz / Siyah	

BRACKET KONSOL

Code / Kod	P	H	L	Description / Açıklama
6A00000004B	300			
6A00000005B	400			

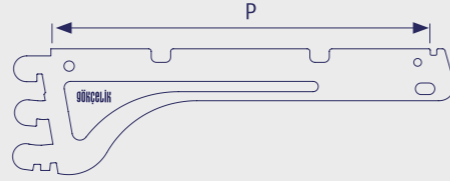

LED POWER SUPPLY GÜÇ KAYNAĞI

Code / Kod	Voltage Voltaj	Description / Açıklama
93000000542	12 V	With Magnet / Miknatıslı

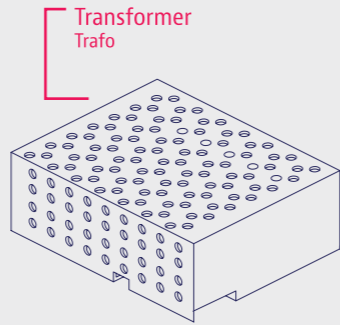

- Led power supply quatites & power will be calculated acc.to project
- Güç Kaynağı sayısı ve gücü projeye göre belirlenir.

POWER CABLE BETWEEN LED POWER SUPPLY AND UNIT LED TRAFOSU VE ÜNİTE ARASI GÜÇ KABLOSU

Code / Kod	Length Uzunluk	Description / Açıklama
9300000681	4000 mm	

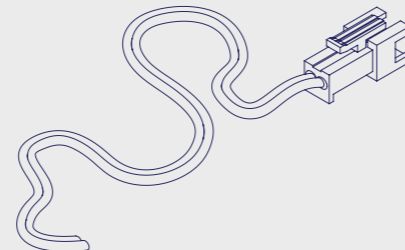

- Power cable lenght will be calculated acc.to project
- Güç kablosu uzunluğu projeye göre hesaplanır.



ILLUMINATION
AYDINLATMA

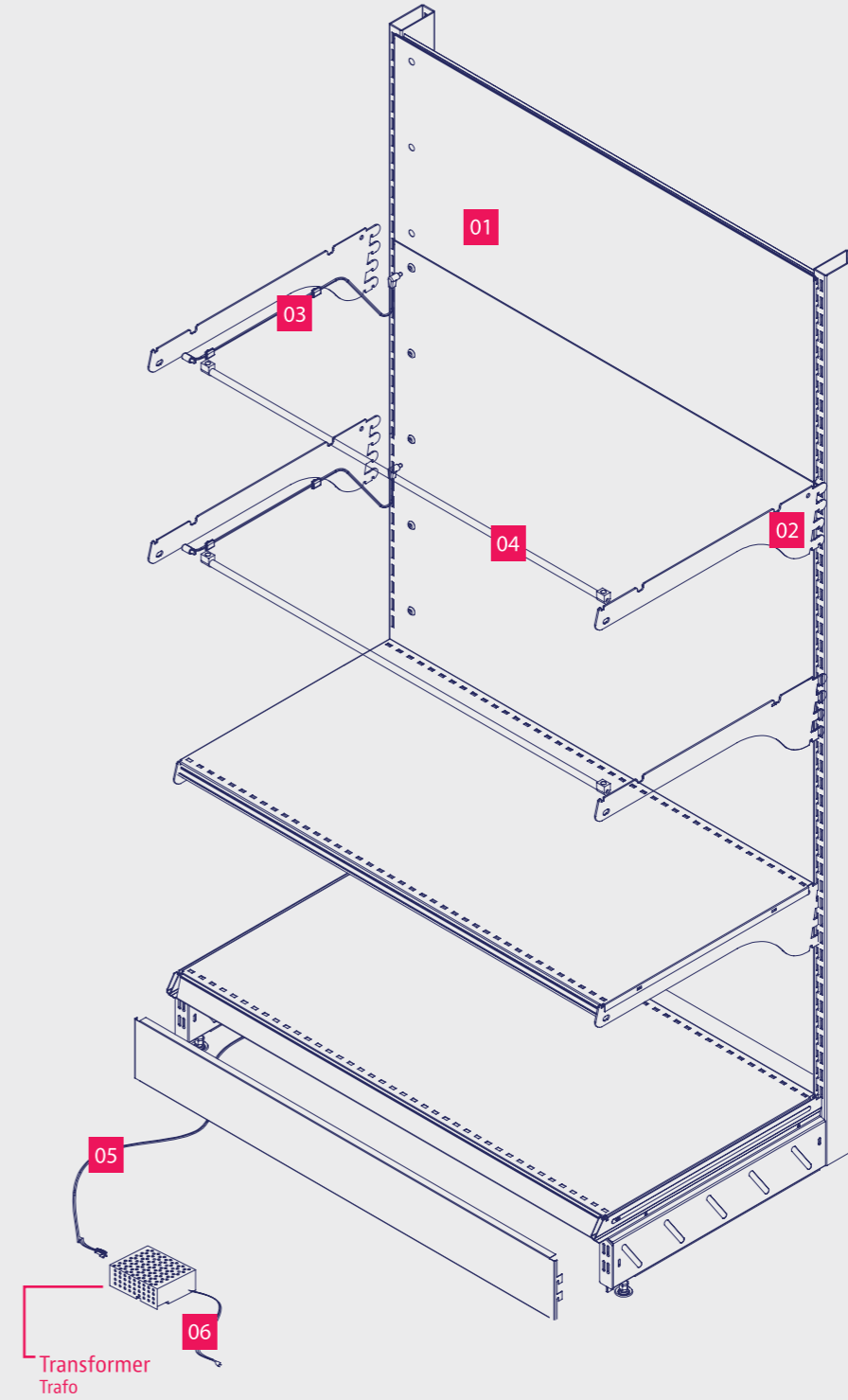

01
Back Panel with Socket
Soket Delikli Arka Pano

02
Bracket
Konsol

03
Connection Cable for Shelf Lighting / 2 Sides with Socket
Soket Ara Bağlantı Kablosu

04
Tube Led
Tüp Led

05
Power Cable Between Led Power Supply and Unit
Led Trafosu Ve Ünite Arası Güç Kablosu

06
Led Power Supply
Güç Kaynağı

F

HEADER ŞAPKA

02

HEADER KUVARZ ŞAPKA KUVARZ

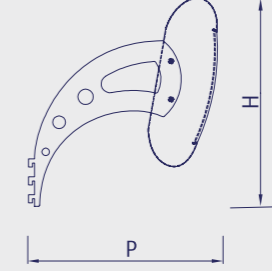
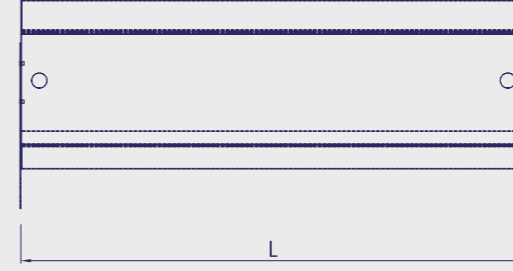

Code / Kod	P	H	L	Description / Açıklama
7A00000001U	300	410	500	
7A00000002U	300	410	700	
7A00000003U	300	410	900	
7A00000004U	300	410	1000	
7A00000005U	300	410	1250	
7A00000006U	300	410	1330	

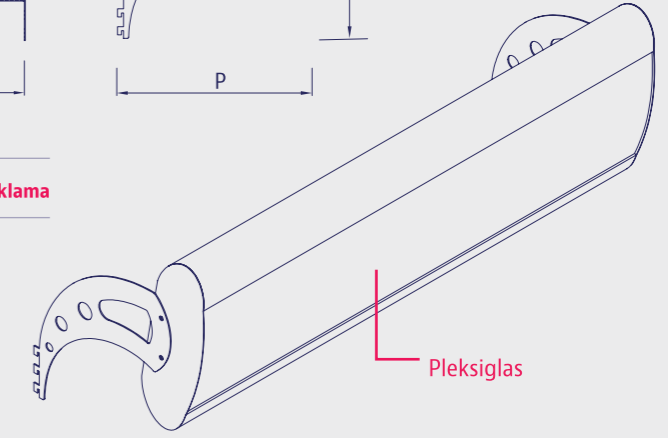

HEADER
ŞAPKA

HEADER SAPHIRE ŞAPKA SAPHIRE

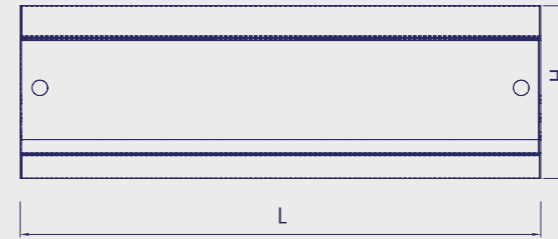

Code / Kod	P	H	L	Description / Açıklama
7A00000007U	180	330	500	
7A00000008U	180	330	700	
7A00000009U	180	330	900	
7A00000010U	180	330	1000	
7A00000011U	180	330	1250	
7A00000012U	180	330	1330	

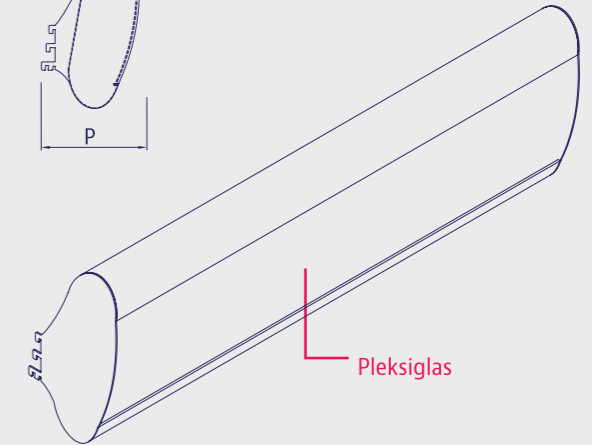



HEADER ŞAPKA

HEADER AQUA ŞAPKA AQUA

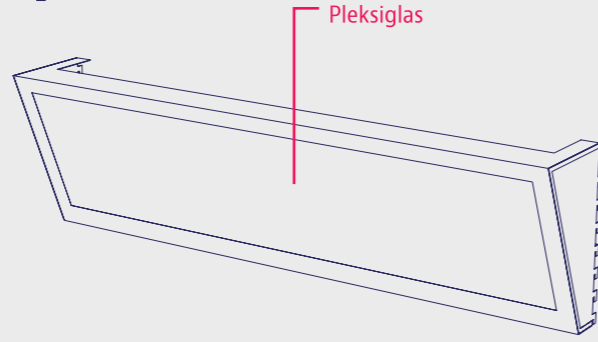
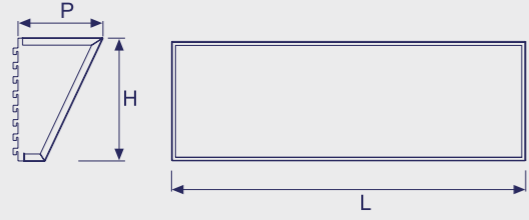

Code / Kod	P	H	L	Description / Açıklama
7A0000013U	215	300	500	Pleksi ve lamba ile beraber ancak lamba projeye göre değişebilir.
7A0000014U	215	300	700	
7A0000015U	215	300	900	
7A0000016U	215	300	1000	
7A0000017U	215	300	1250	
7A0000018U	215	300	1330	

HEADER MARINE ŞAPKA MARINE

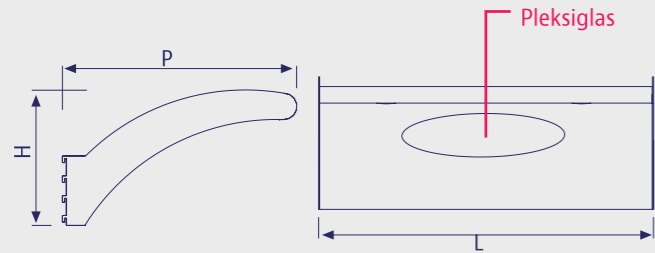

Code / Kod	P	H	L	Description / Açıklama
7A0000019U	686	400	500	
7A0000020U	686	400	700	
7A0000021U	686	400	900	
7A0000022U	686	400	1000	
7A0000023U	686	400	1250	
7A0000024U	686	400	1330	

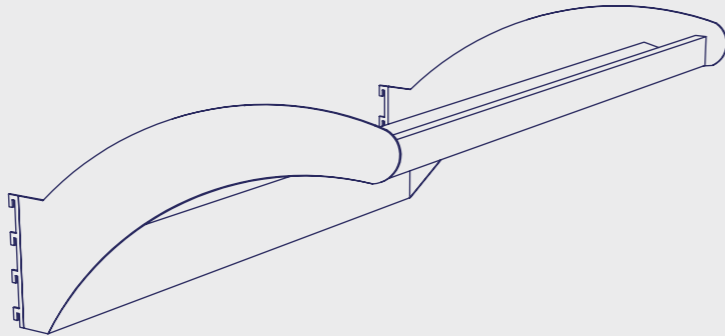

HEADER OLIVE ŞAPKA OLIVE

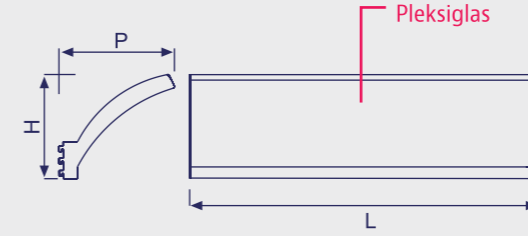

Code / Kod	P	H	L	Description / Açıklama
7A0000025U	300	360	500	Pleksi ve lamba ile beraber ancak lamba projeye göre değişebilir.
7A0000026U	300	360	700	
7A0000027U	300	360	900	
7A0000028U	300	360	1000	
7A0000029U	300	360	1250	
7A0000030U	300	360	1330	

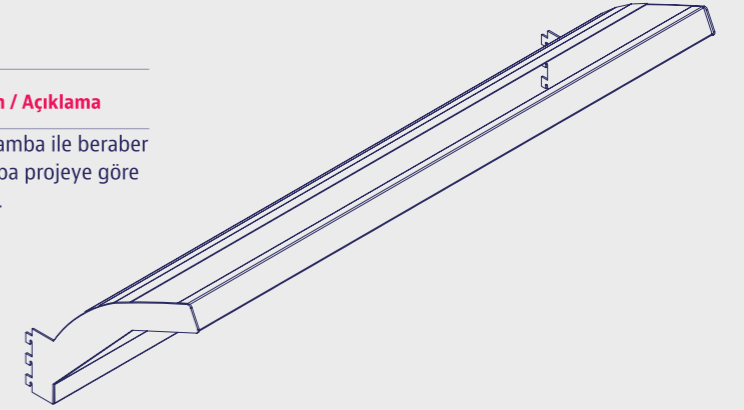

HEADER RUBY ŞAPKA RUBY

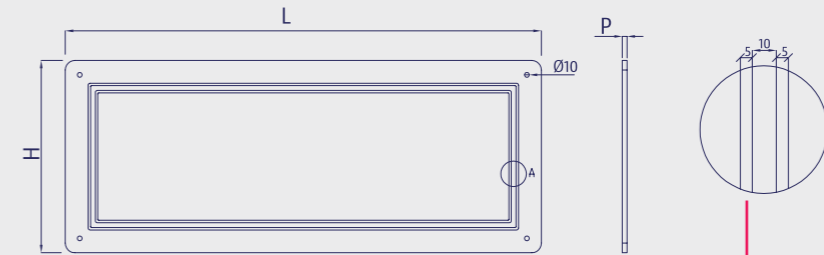

Channel Detail
Kanal Detayı

Code / Kod	P	H	L	Description / Açıklama
7A0000054M	10	400	500	
7A0000055M	10	400	700	
7A0000056M	10	400	900	
7A0000057M	10	400	1000	
7A0000058M	10	400	1250	
7A0000059M	10	400	1330	

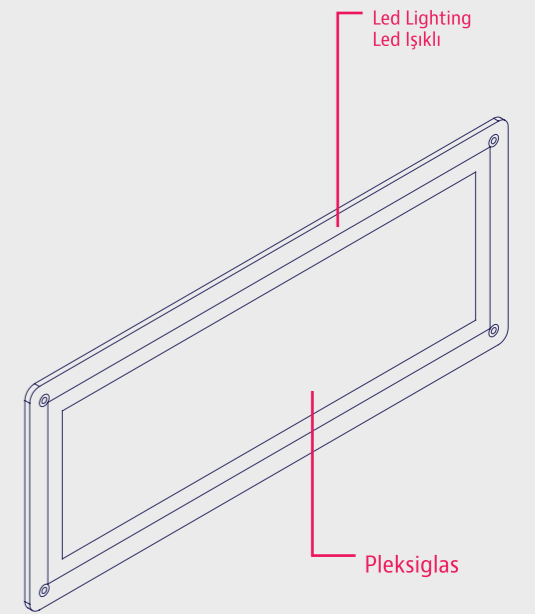



HEADER
ŞAPKA

■ HEADER JADE 1-2
ŞAPKA JADE 1-2

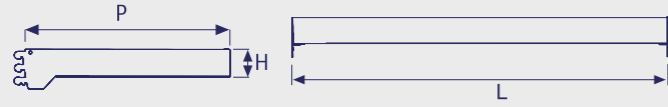

Code / Kod	P	H	L	Description / Açıklama
7A00000037U	430	70	500	
7A00000038U	430	70	700	
7A00000039U	430	70	900	
7A00000040U	430	70	1000	
7A00000041U	430	70	1250	
7A00000042U	430	70	1330	
7A00000043U	530	70	500	
7A00000044U	530	70	700	
7A00000045U	530	70	900	
7A00000046U	530	70	1000	
7A00000047U	530	70	1250	

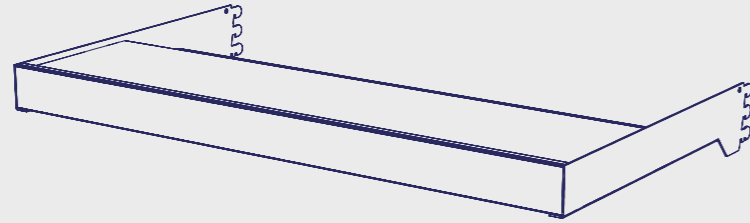

■ HEADER MERCAN
ŞAPKA MERCAN

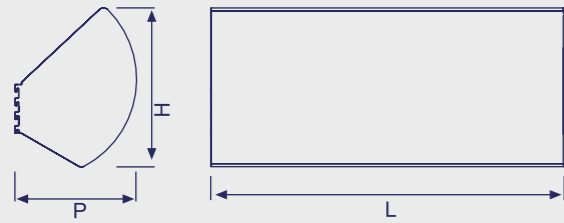

Code / Kod	P	H	L	Description / Açıklama
7A00000048U	310	420	500	
7A00000049U	310	420	700	
7A00000050U	310	420	900	
7A00000051U	310	420	1000	
7A00000052U	310	420	1250	
7A00000053U	310	420	1330	

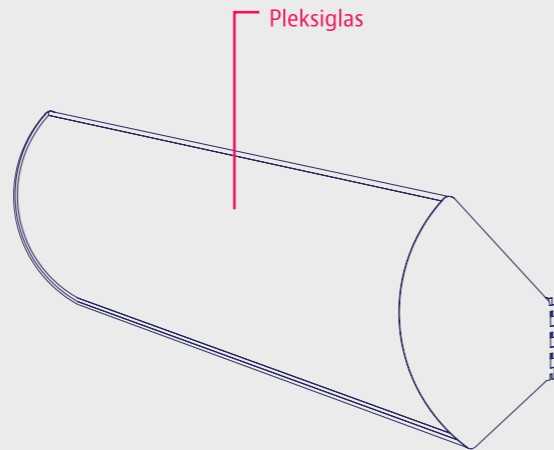

■ HEADER FOR GONDOLA UNIT FELIX
ORTA REYON ŞAPKA FELIX

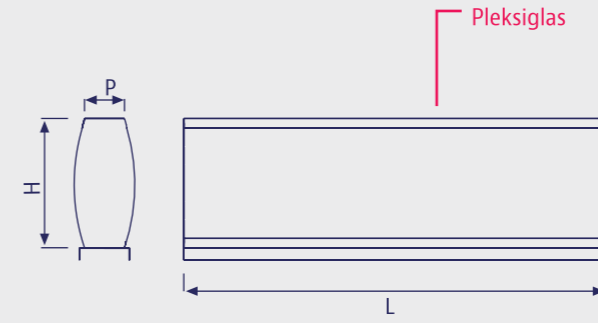

Code / Kod	P	H	L	Description / Açıklama
7A00000060U	240	410	500	
7A00000061U	240	410	700	
7A00000062U	240	410	900	
7A00000063U	240	410	1000	
7A00000064U	240	410	1250	
7A00000065U	240	410	1330	

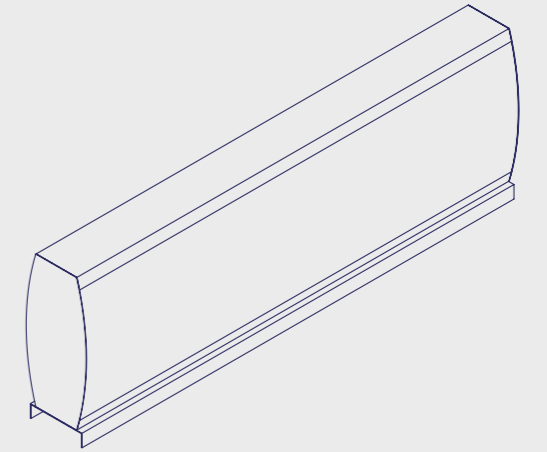

■ HEADER ROSE
ŞAPKA ROSE (TEK YÖN)

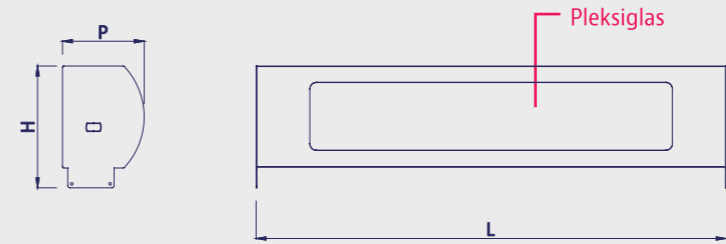

Code / Kod	P	H	L	Description / Açıklama
7A00000169U	124	184	500-SB	
7A00000170U	124	184	700-SB	
7A00000171U	124	184	900-SB	
7A00000172U	124	184	1000-SB	
7A00000173U	124	184	1250-SB	
7A00000174U	124	184	1330-SB	

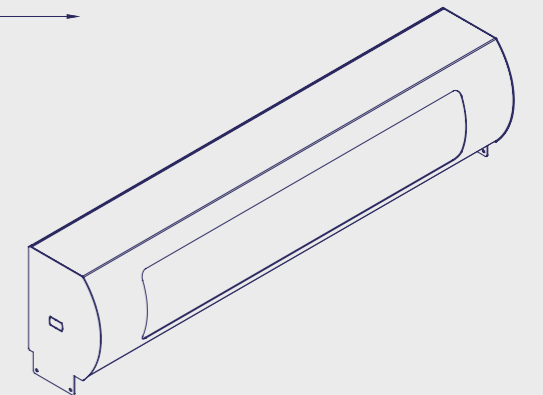



HEADER
ŞAPKA

■ HEADER ROSE
ŞAPKA ROSE



Code / Kod	P	H	L	Description / Açıklama
7A0000066U	165	185	500	
7A0000067U	165	185	700	
7A0000068U	165	185	900	
7A0000069U	165	185	1000	
7A0000070U	165	185	1250	
7A0000071U	165	185	1330	

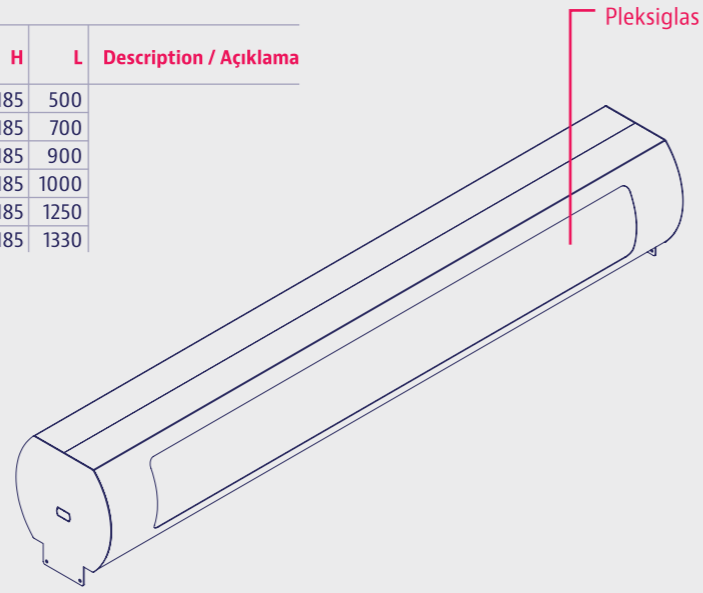

■ HEADER OHAIN
ŞAPKA OHAIN

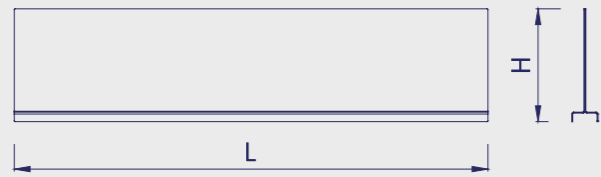

Code / Kod	P	H	L	Description / Açıklama
10B0000117B		130	600	

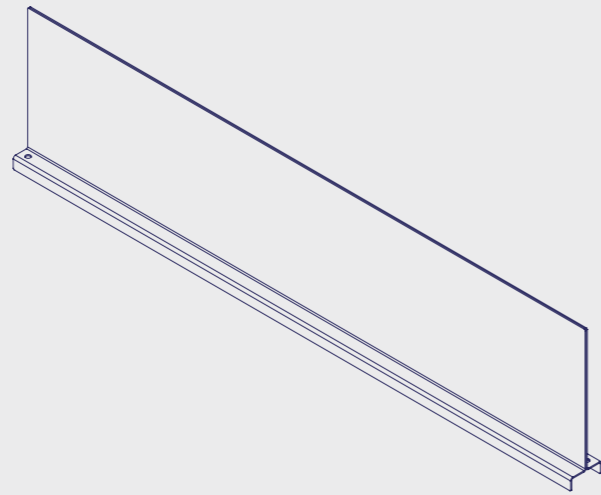

■ HEADER TURMALIN
ŞAPKA TURMALİN

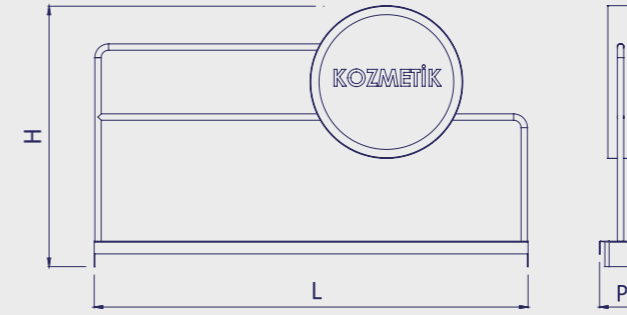

Code / Kod	P	H	L	Description / Açıklama
7A00000151U	99	615	500	
7A00000152U	99	615	700	
7A00000153U	99	615	900	
7A00000154U	99	615	1000	
7A00000155U	99	615	1250	
7A00000156U	99	615	1330	

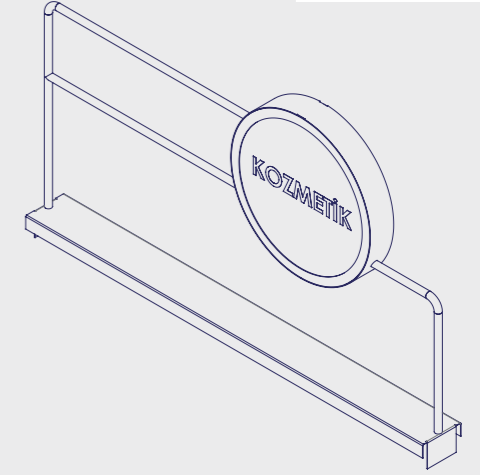

■ HEADER PATELİT
ŞAPKA PETALİT



Code / Kod	P	H	L	Description / Açıklama
7A00000157U	284	625	500	
7A00000158U	284	625	700	
7A00000159U	284	625	900	
7A00000160U	284	625	1000	
7A00000161U	284	625	1250	
7A00000162U	284	625	1330	

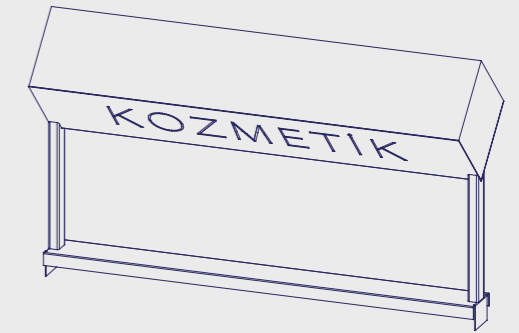



HEADER ŞAPKA

HEADER ONIKS ŞAPKA ONIKS

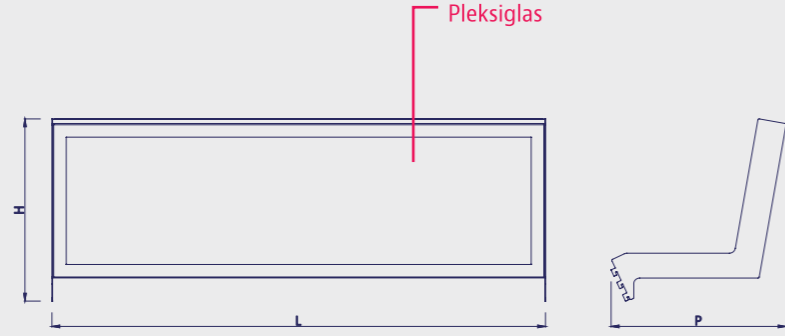

Code / Kod	P	H	L	Description / Açıklama
7A00000175U	165	185	500	
7A00000176U	165	185	700	
7A00000177U	165	185	900	
7A00000178U	165	185	1000	
7A00000142U	165	185	1250	
7A00000179U	165	185	1330	

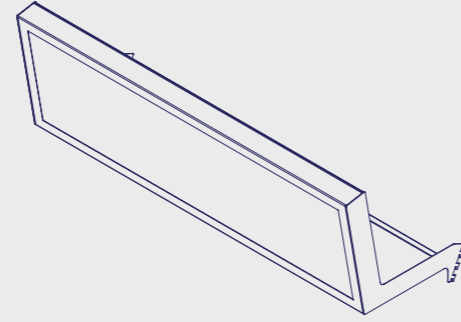

HEADER LAPİS ŞAPKA LAPİS

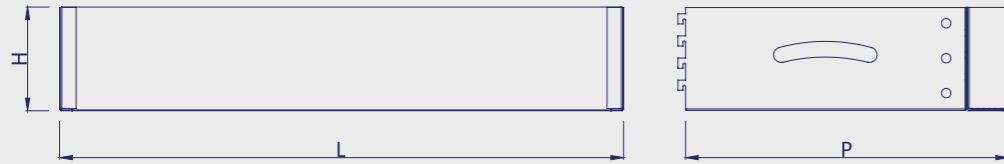

Code / Kod	P	H	L	Description / Açıklama
7A00000163U	510	165	500	
7A00000164U	510	165	700	
7A00000165U	510	165	900	
7A00000166U	510	165	1000	
7A00000167U	510	165	1250	
7A00000168U	510	165	1330	

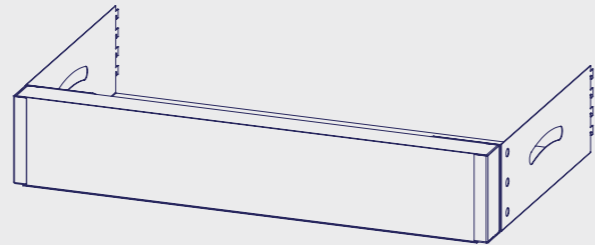

HEADER SAFARİ ŞAPKA SAFARİ

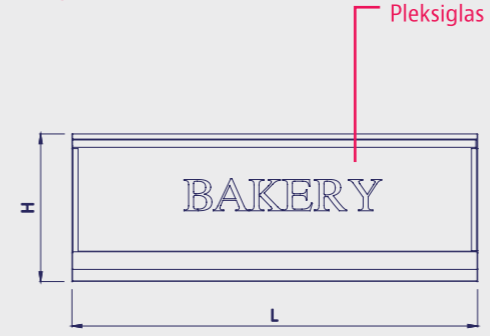

Code / Kod	P	H	L	Description / Açıklama
7A00000146U	400	363	500	
7A00000147U	400	363	700	
7A00000148U	400	363	900	
7A00000132U	400	363	1000	
7A00000149U	400	363	1250	
7A00000150U	400	363	1330	

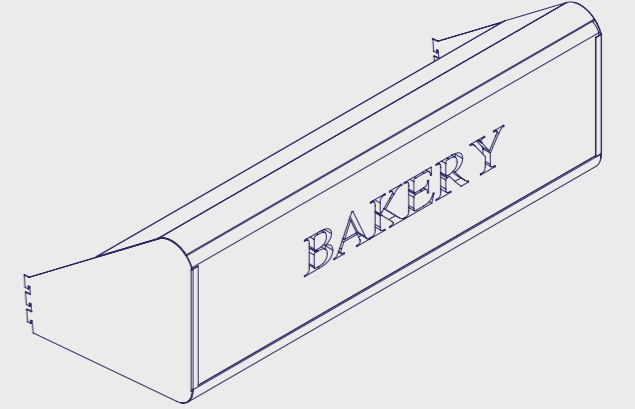

HEADER OPERA ŞAPKA OPERA

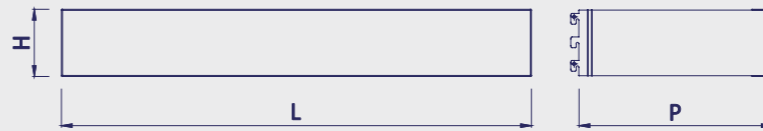

Code / Kod	P	H	L	Description / Açıklama
7A00000083B	300	100	500	
7A00000084B	300	100	700	
7A00000085B	300	100	900	
7A00000086B	300	100	1000	
7A00000087B	300	100	1250	
7A00000088B	300	100	1330	
7A00000089B	400	100	500	
7A00000090B	400	100	700	
7A00000091B	400	100	900	
7A00000092B	400	100	1000	
7A00000093B	400	100	1250	
7A00000094B	400	100	1330	

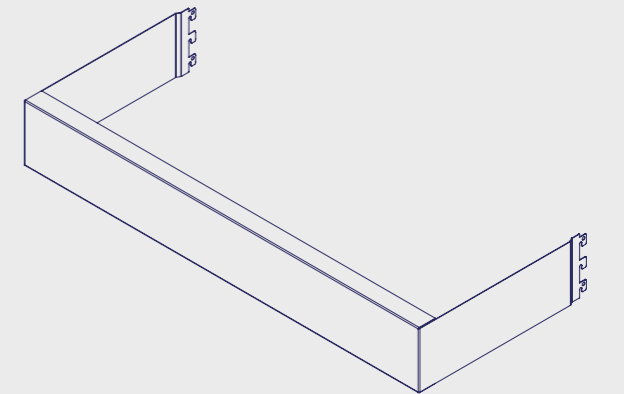



HEADER ŞAPKA

HEADER OPERA ŞAPKA OPERA

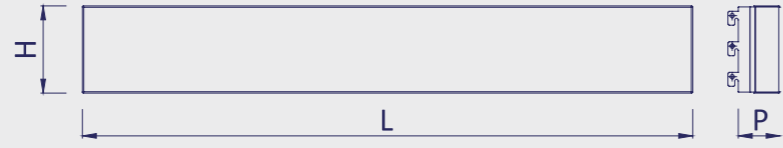

Code / Kod	P	H	L	Description / Açıklama
7A00000077B	60	100	500	
7A00000078B	60	100	700	
7A00000079B	60	100	900	
7A00000080B	60	100	1000	
7A00000081B	60	100	1250	
7A00000082B	60	100	1330	

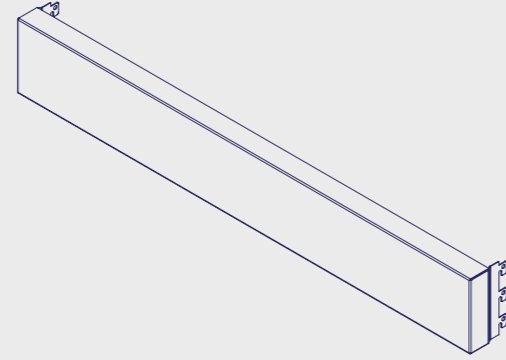

HEADER KALSEDON ŞAPKA KALSEDON

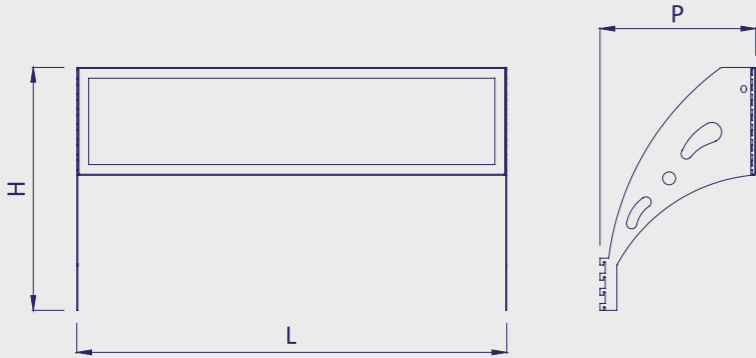

Code / Kod	P	H	L	Description / Açıklama
7A00000136U	360	563	500	
7A00000137U	360	563	700	
7A00000138U	360	563	900	
7A00000139U	360	563	1000	
7A00000140U	360	563	1250	
7A00000141U	360	563	1330	

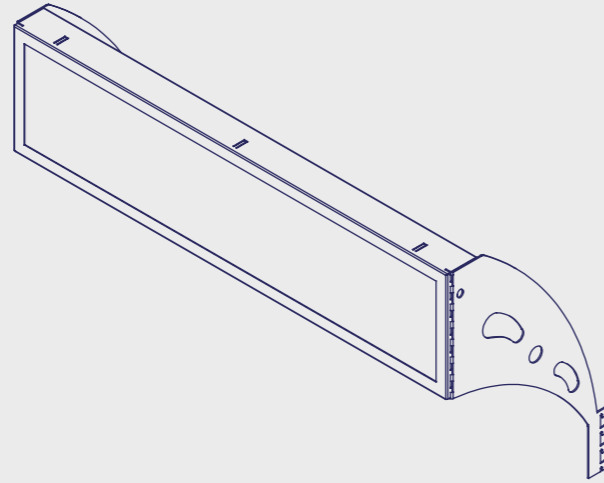

HEADER FRONT PANEL ŞAPKA ÖN PANEL

Code / Kod	P	H	L	Description / Açıklama
7B00000009B		150	500	
7B00000010B		150	700	
7B00000011B		150	900	
7B00000012B		150	1000	
7B00000013B		150	1250	
7B00000014B		150	1330	

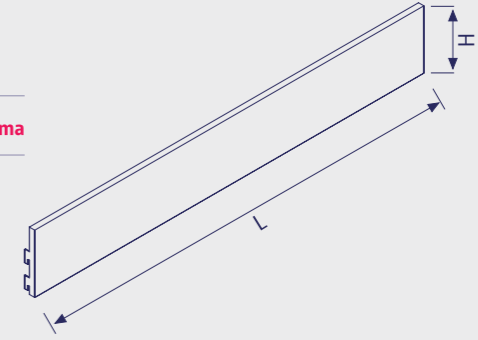

HEADER FRONT PANEL EXTERNAL CORNER ŞAPKA ÖN PANEL DIŞ KÖŞE

Code / Kod	P	H	L	Description / Açıklama
7B00000015B	300	150		
7B00000016B	400	150		
7B00000017B	500	150		
7B00000018B	600	150		

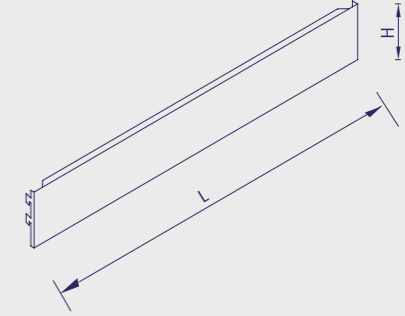

HEADER FRONT PANEL INTERNAL CORNER ŞAPKA ÖN PANEL İÇ KÖŞE

Code / Kod	P	H	L	Description / Açıklama
7B00000019B	300	150		For internal corner
7B00000020B	400	150		İç köşe için
7B00000021B	500	150		
7B00000022B	600	150		

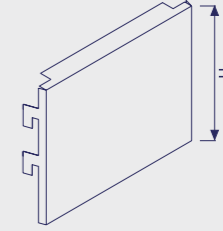

HEADER BRACKET ŞAPKA KONSOLU

Code / Kod	P	H	L	Description / Açıklama
7B00000005B	300	150		
7B00000006B	400	150		
7B00000007B	500	150		
7B00000008B	600	150		

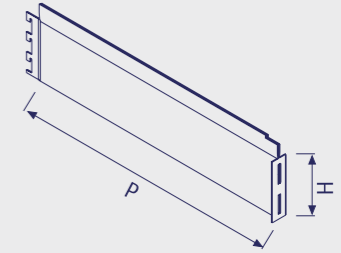

HEADER ENDING SET ŞAPKA BİTİŞ KONSOL TAKIMI

Code / Kod	P	H	L	Description / Açıklama
7B00000001.1B	300	150		Sağ / Right
7B00000002.1B	400	150		
7B00000003.1B	500	150		
7B00000004.1B	600	150		
7B00000001.2B	300	150		Sol / Left
7B00000002.2B	400	150		
7B00000003.2B	500	150		
7B00000004.2B	600	150		

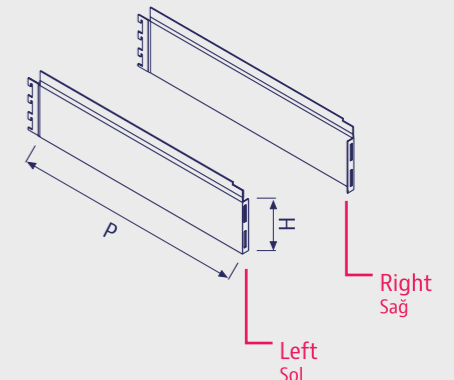



HEADER
ŞAPKA

■ SAMPLE UNITS
WITH HEADER
ŞAPKALI ÜNİTE
ÖRNEKLERİ

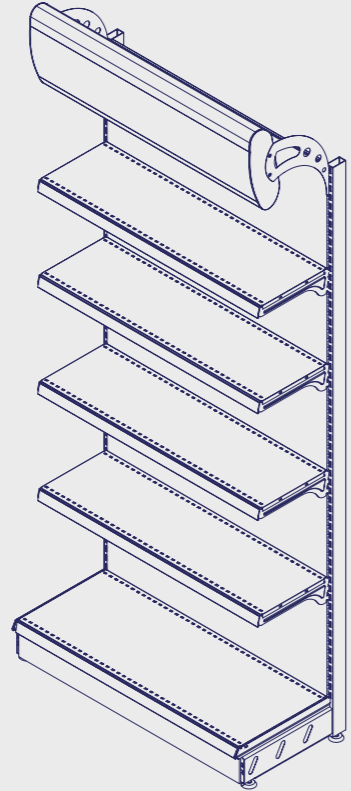
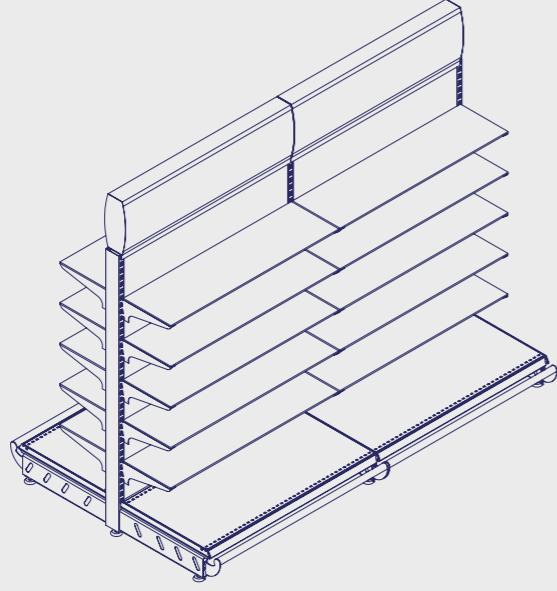

HEADER
ŞAPKA

■ SAMPLE UNITS
WITH HEADER
ŞAPKALI ÜNİTE
ÖRNEKLERİ

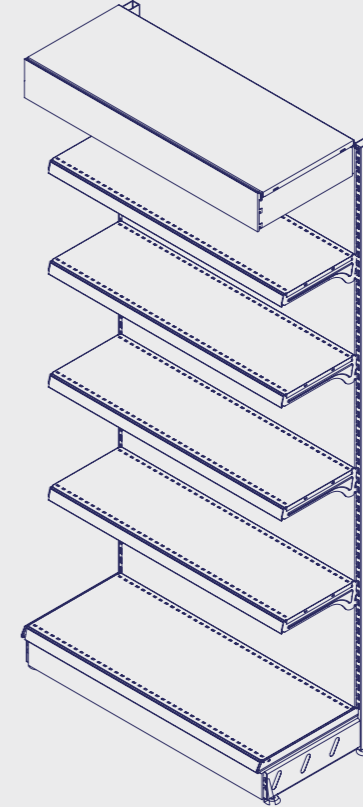
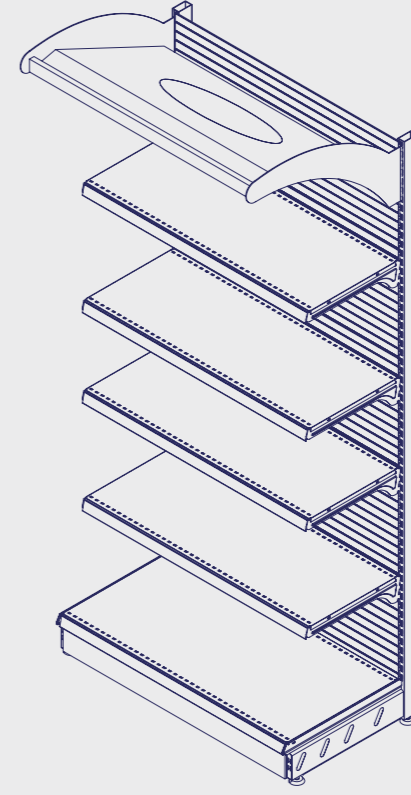



BAKERIES
UNLU MAMÜLLER



BAKERIES
UNLU MAMÜLLER

ALTUN BAKERY UNIT
WITH SHELVES
ALTUN UNLU MAMÜL
REYONU - RAFLI

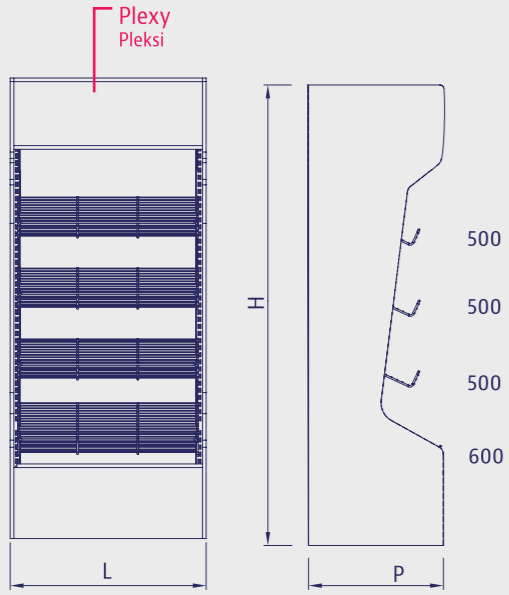

Code / Kod	P	H	L	Description / Açıklama
14A0000016U	600	2270	700	Header with Lighting
14A0000001U	600	2270	900	Aydınlatmalı Ahşap Şapka

ALTUN BAKERY UNIT
WITH CUPBOARD
ALTUN UNLU MAMÜL
REYONU - DOLAPLI

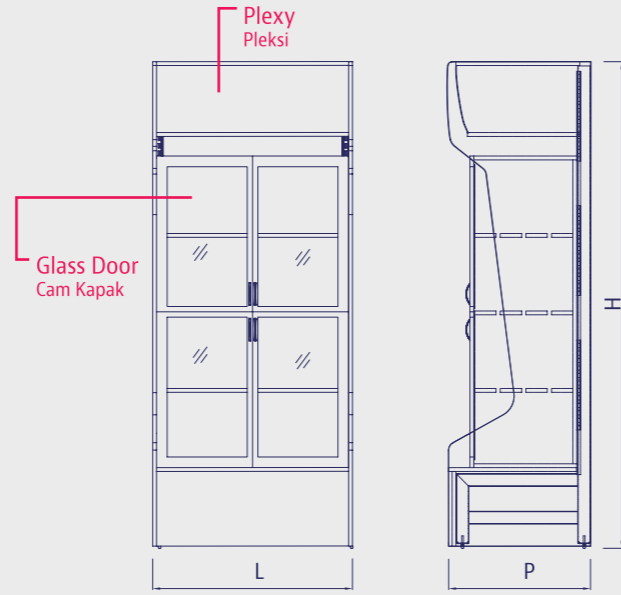

Code / Kod	P	H	L	Description / Açıklama
14A0000017U	600	2270	700	
14A0000002U	600	2270	900	

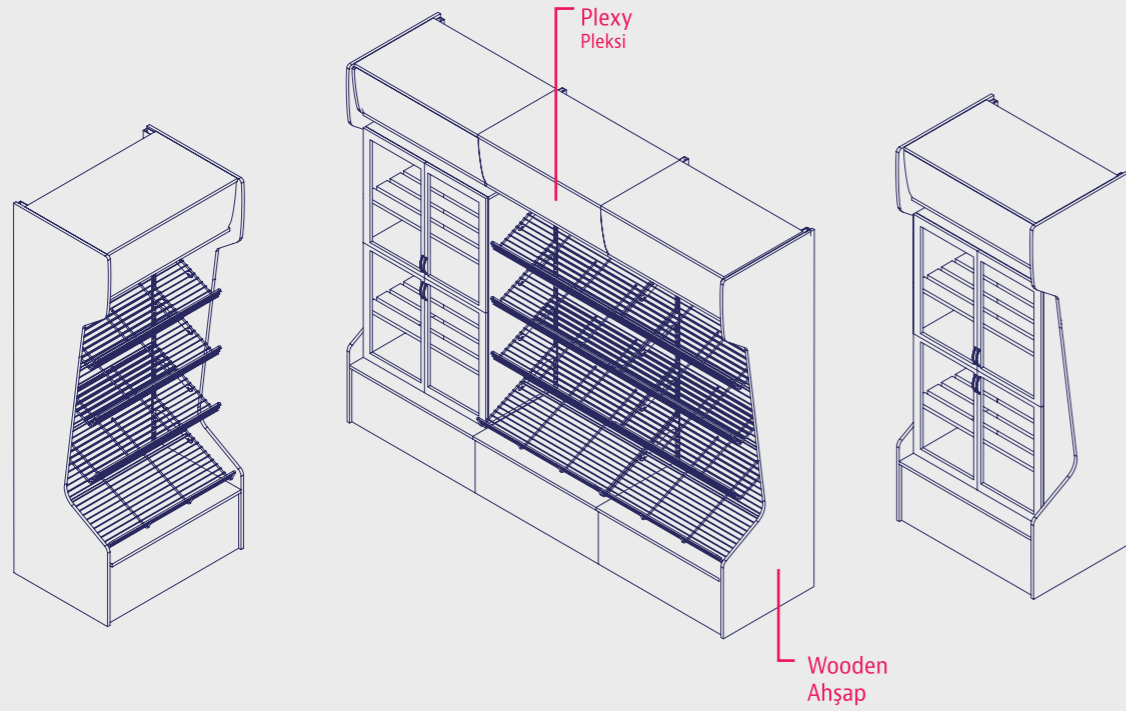

BAKERIES
UNLU MAMÜLLER

LOTUS BAKERY UNIT
LOTUS UNLU MAMÜL REYONU

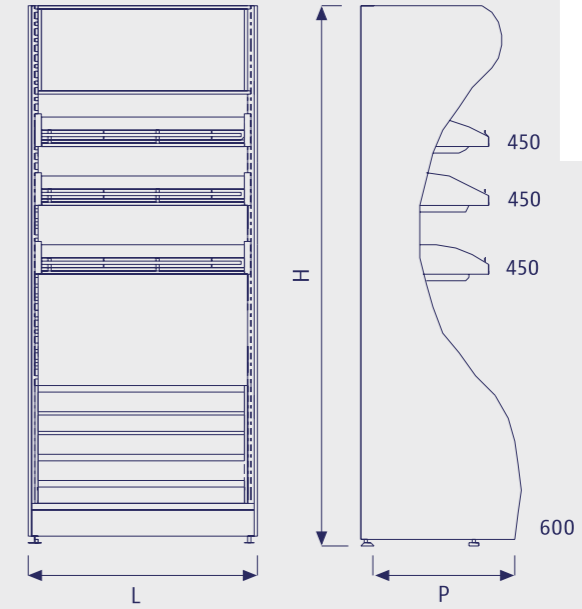
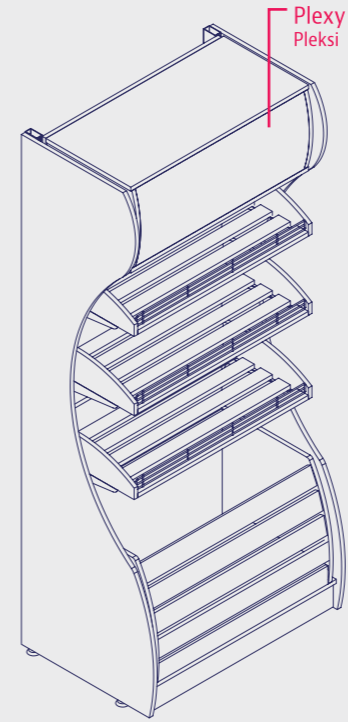

Code / Kod	P	H	L	Description / Açıklama
14A0000018U	600	2270	700	Header with Lighting
14A0000019U	600	2270	900	Aydınlatmalı Ahşap Şapka

ROYAL BAKERY UNIT
ROYAL UNLU MAMÜL REYONU REYONU

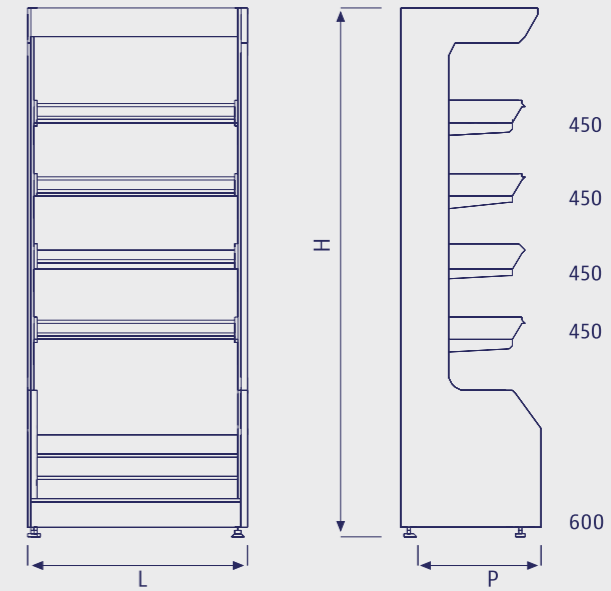
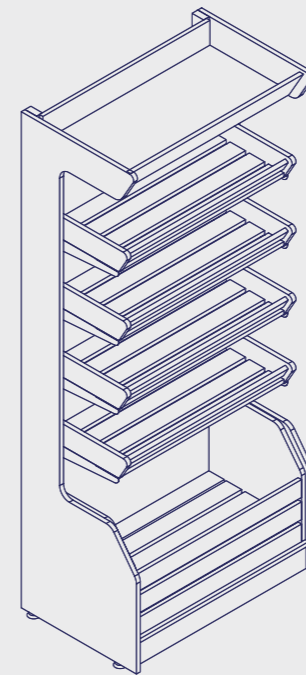

Code / Kod	P	H	L	Description / Açıklama
14A0000021U	600	2270	700	
14A0000022U	600	2270	900	



BAKERIES
UNLU MAMÜLLER

PRUNUS BAKERY UNIT
PRUNUS UNLU MAMÜL REYONU

RUBUS BAKERY UNIT
RUBUS UNLU MAMÜL REYONU

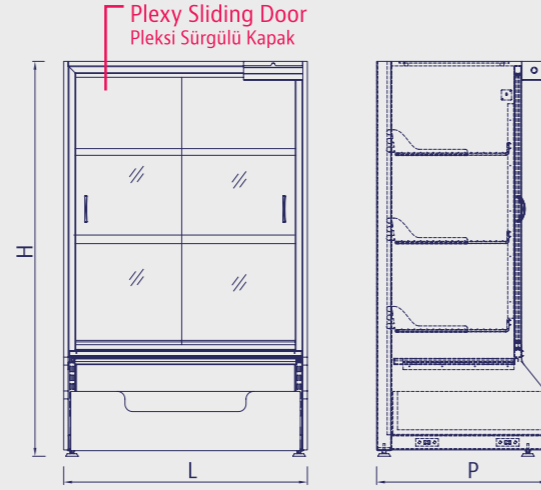
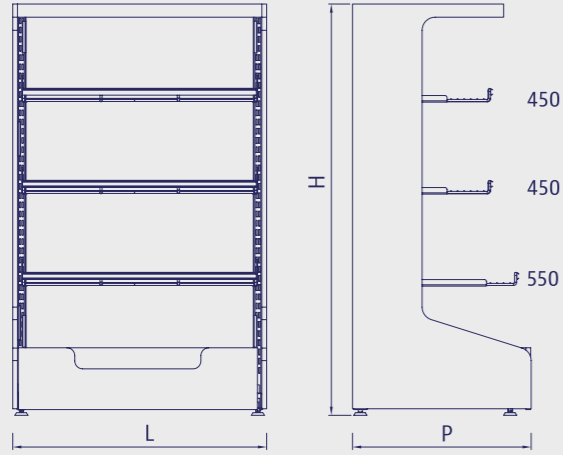

Code / Kod	P	H	L	Description / Açıklama
14A0000004U	680	1540	966	

Code / Kod	P	H	L	Description / Açıklama
14A0000005U	680	1540	966	

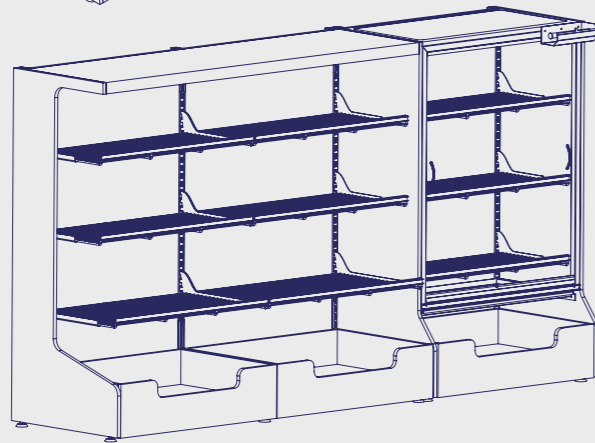
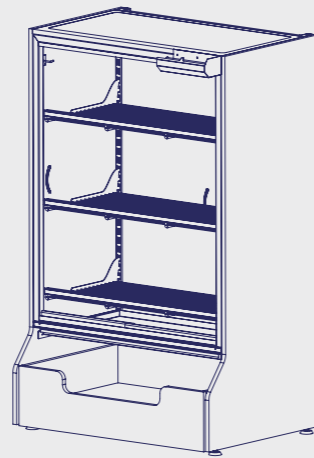
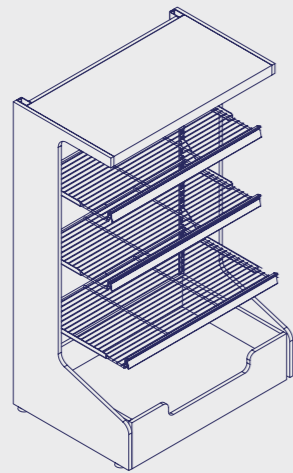

BAKERIES
UNLU MAMÜLLER

SEDUM BAKERY UNIT
SEDUM UNLU MAMÜL REYONU

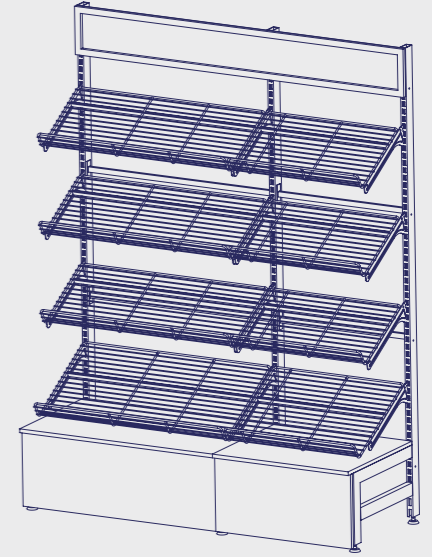
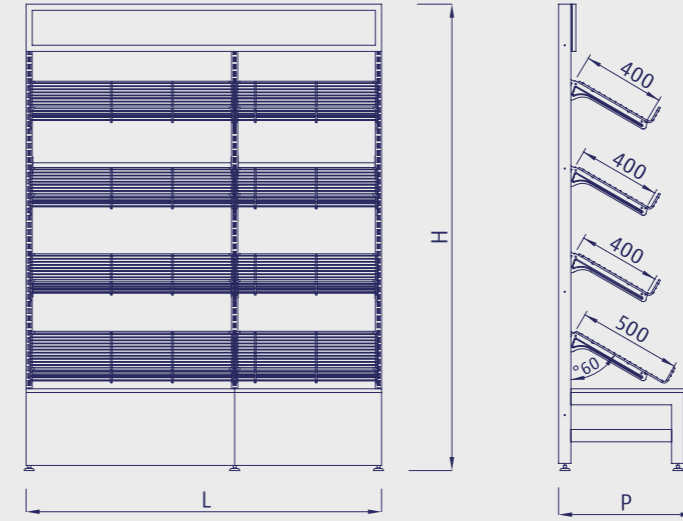

Code / Kod	P	H	L	Description / Açıklama
14A0000008U	660	2270	700	
14A0000007U	660	2270	900	
14A0000010U	660	2270	1000	

HERBA BAKERY UNIT
HERBA UNLU MAMÜL REYONU

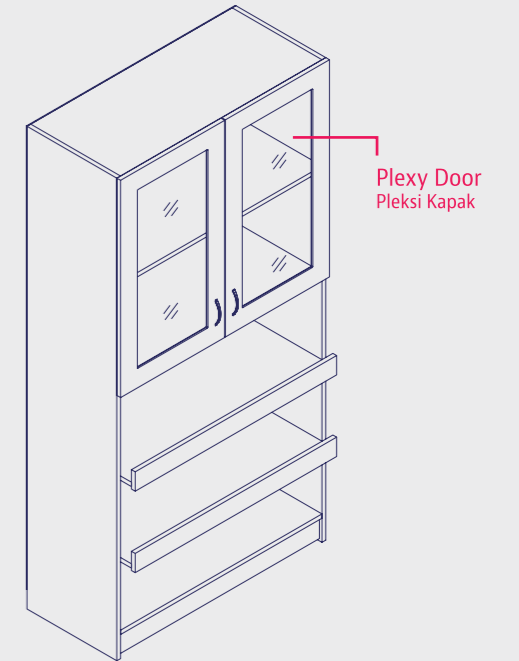
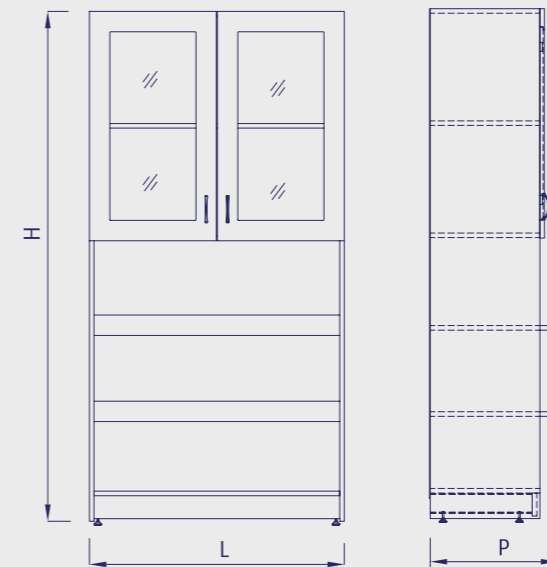

Code / Kod	P	H	L	Description / Açıklama
14A0000013U	500	2000	1000	



BAKERIES
UNLU MAMÜLLER

NEST BAKERY UNIT NEST UNLU MAMÜL REYONU

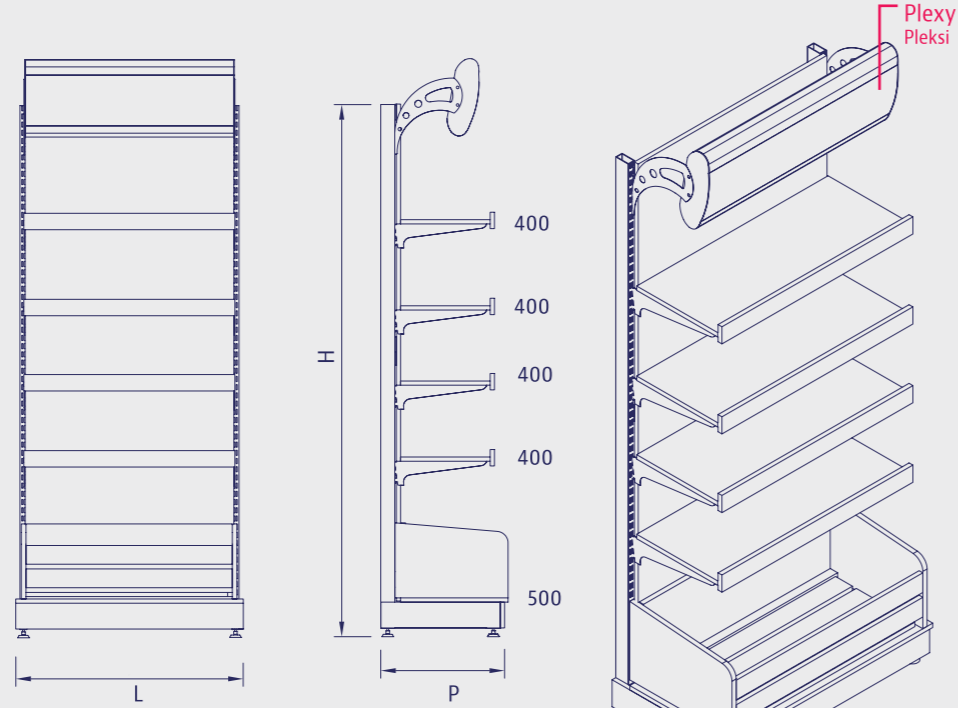

Code / Kod	P	H	L	Description / Açıklama
14A0000024U	500	2270	700	Metal Header With Lighting
14A0000025U	500	2270	900	Aydınlatmalı Metal Şapka

ROSA BAKERY UNIT ROSA UNLU MAMÜL REYONU

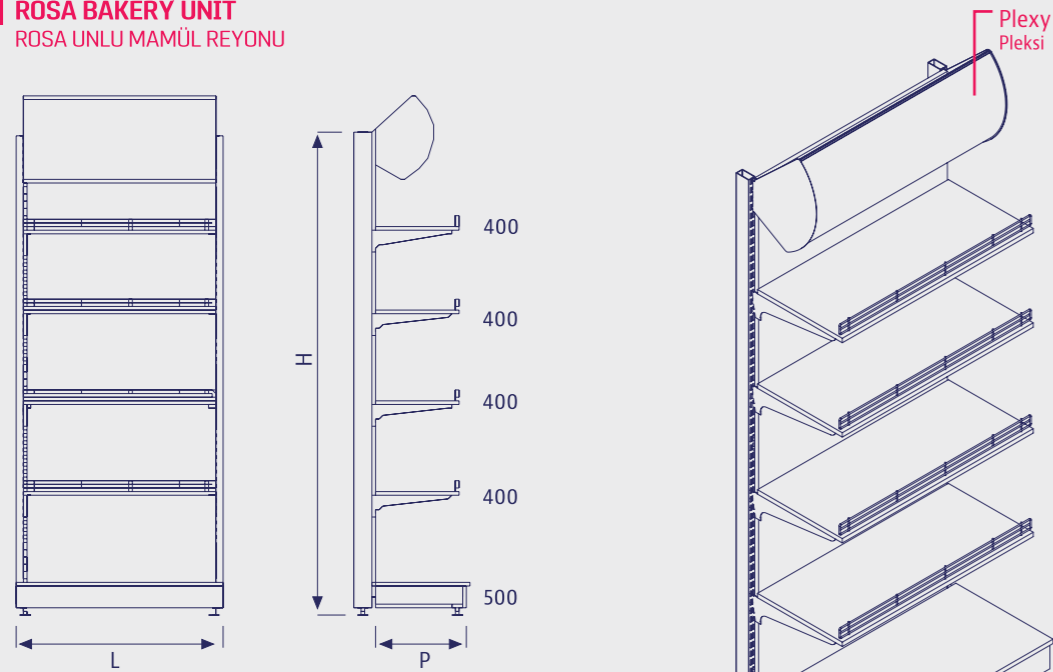

Code / Kod	P	H	L	Description / Açıklama
14A0000027U	500	2270	700	Metal Header With Lighting
14A0000028U	500	2270	900	Aydınlatmalı Metal Şapka

FAGUS BAKERY UNIT FAGUS UNLU MAMÜL REYONU

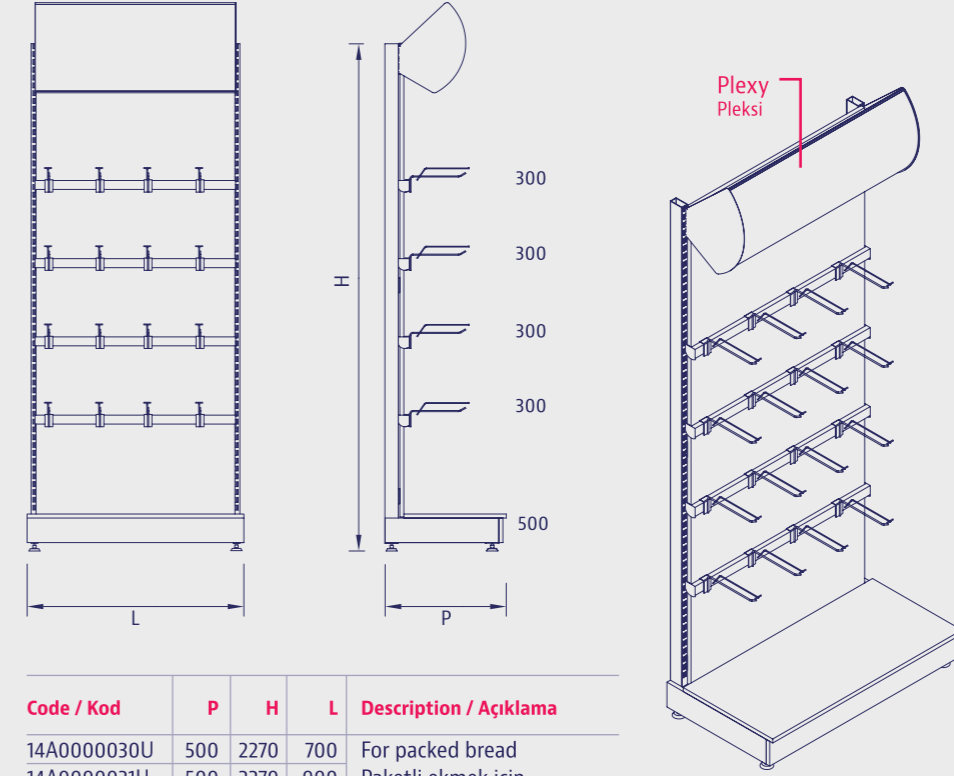

Code / Kod	P	H	L	Description / Açıklama
14A0000030U	500	2270	700	For packed bread
14A0000031U	500	2270	900	Paketli ekmeK için Metal Header With Lighting Aydınlatmalı Metal Şapka

THUNA BAKERY UNIT THUNA UNLU MAMÜL REYONU

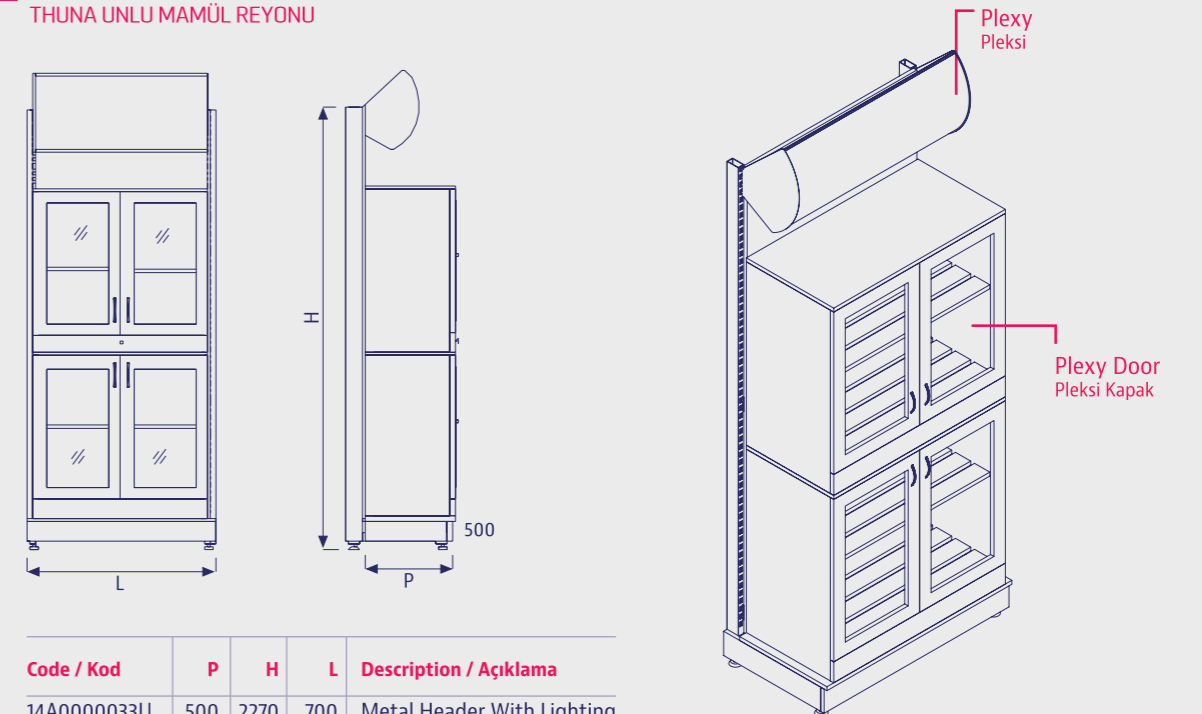

Code / Kod	P	H	L	Description / Açıklama
14A0000033U	500	2270	700	Metal Header With Lighting
14A0000034U	500	2270	900	Aydınlatmalı Metal Şapka



BAKERIES
UNLU MAMÜLLER

ACER BAKERY UNIT
ACER UNLU MAMÜL REYONU

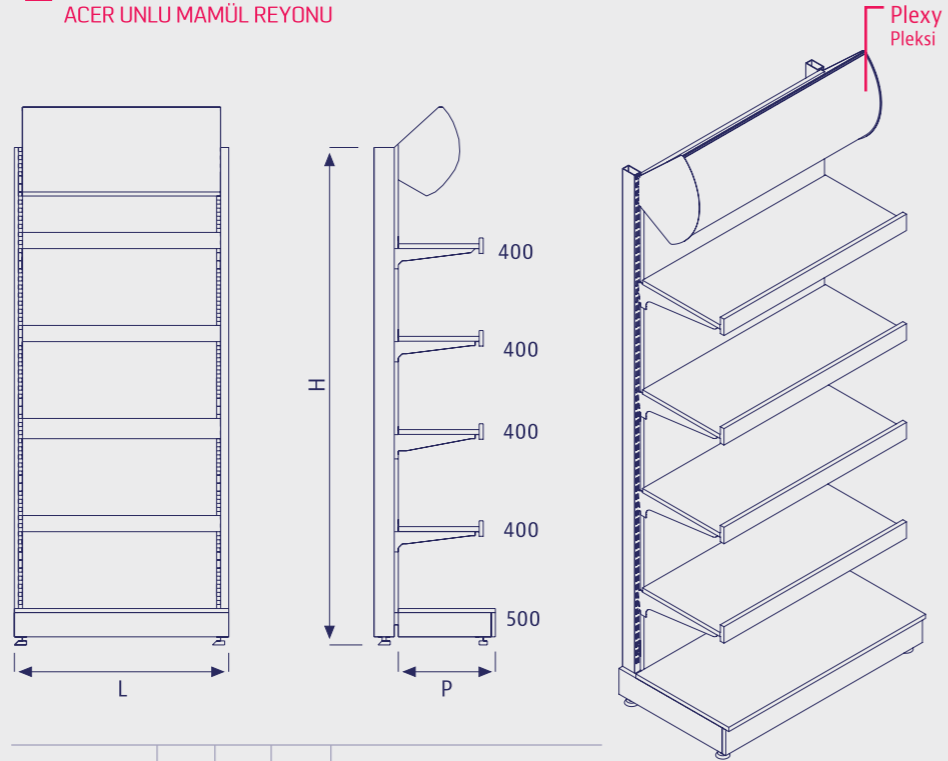

Code / Kod	P	H	L	Description / Açıklama
14A0000036U	500	2270	700	Metal Header With Lighting
14A0000037U	500	2270	900	Aydınlatmalı Metal Şapka



BAKERIES
UNLU MAMÜLLER

SEMEN BAKERY UNIT
SEMEN UNLU MAMÜL REYONU

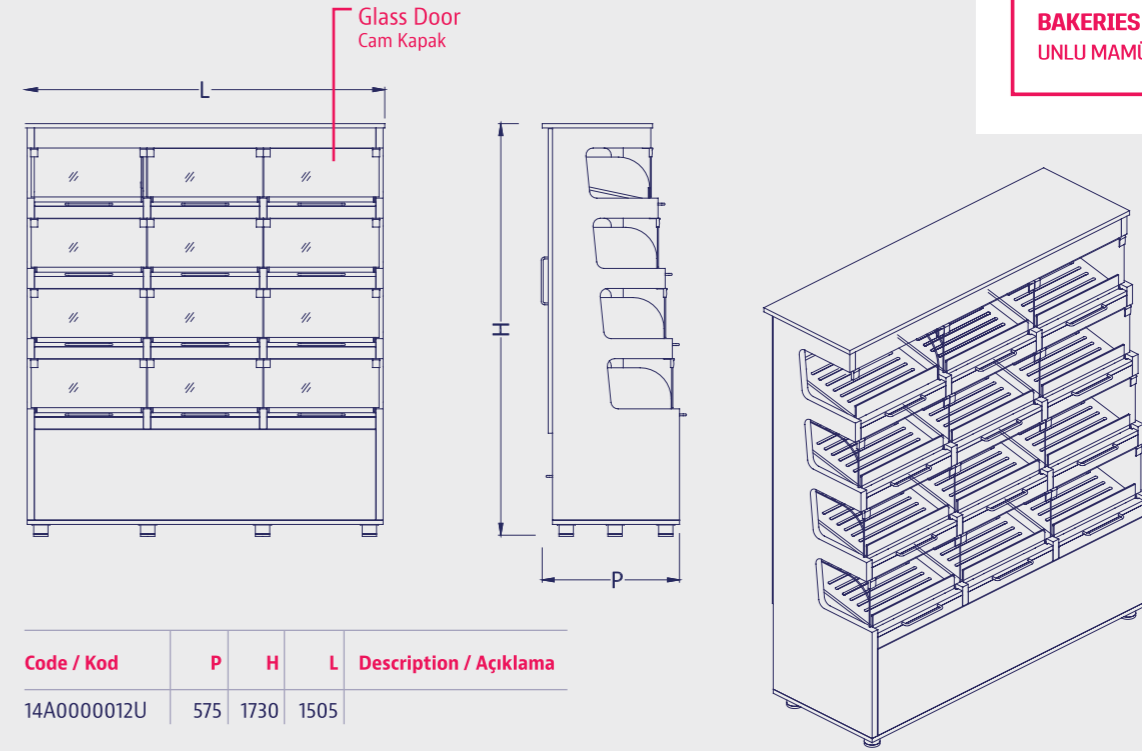

Code / Kod	P	H	L	Description / Açıklama
14A0000012U	575	1730	1505	

LADEN BAKERY UNIT
LADEN UNLU MAMÜL REYONU

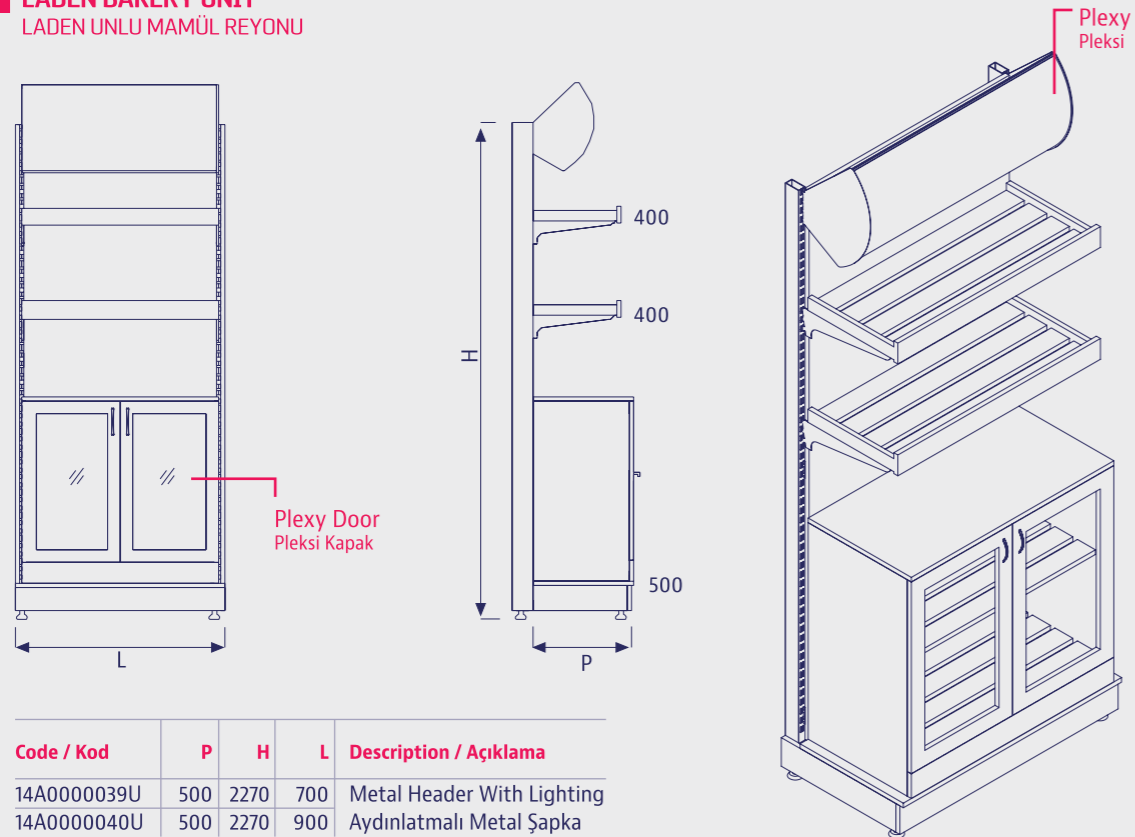

Code / Kod	P	H	L	Description / Açıklama
14A0000039U	500	2270	700	Metal Header With Lighting
14A0000040U	500	2270	900	Aydınlatmalı Metal Şapka

MORUS BAKERY UNIT
MORUS UNLU MAMÜL REYONU

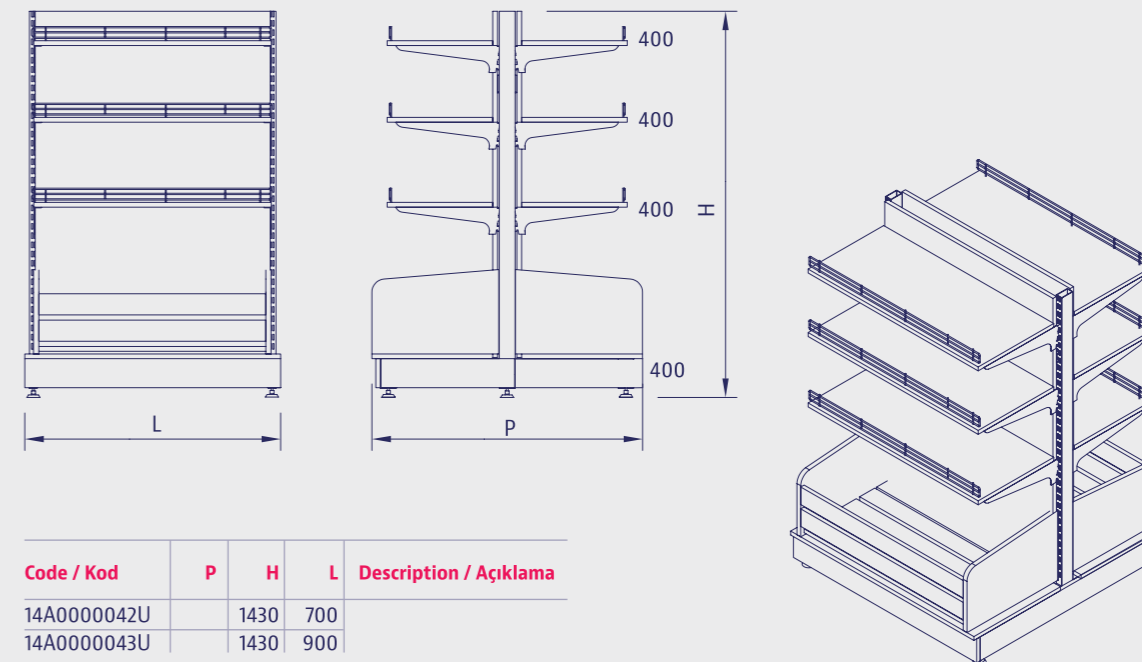

Code / Kod	P	H	L	Description / Açıklama
14A0000042U		1430	700	
14A0000043U		1430	900	



BAKERIES
UNLU MAMÜLLER

SOLANUM BAKERY UNIT
SOLANUM UNLU MAMÜL REYONU

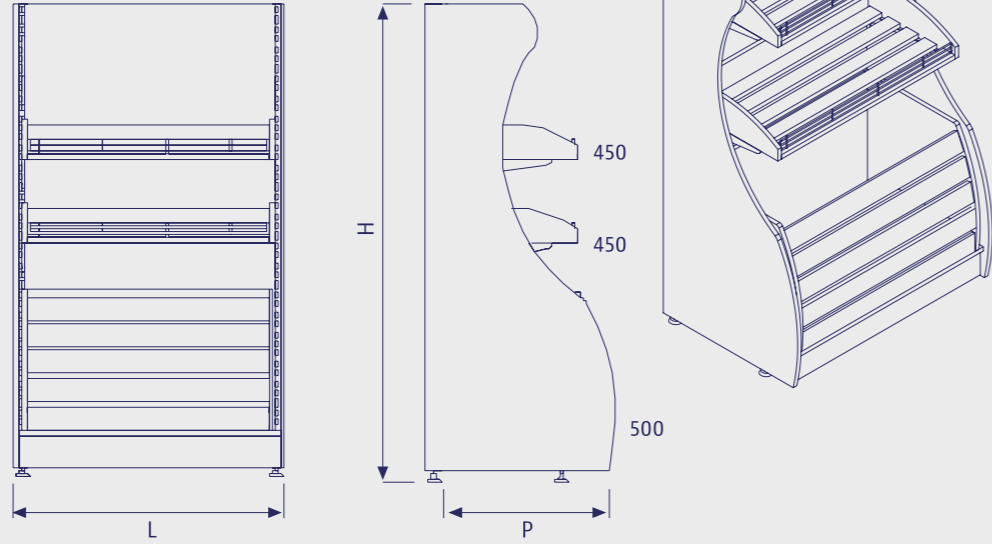

Code / Kod	P	H	L	Description / Açıklama
14A0000045U	500	1430	700	
14A0000046U	500	1430	900	

MORUS BAKERY UNIT
MORUS UNLU MAMÜL REYONU

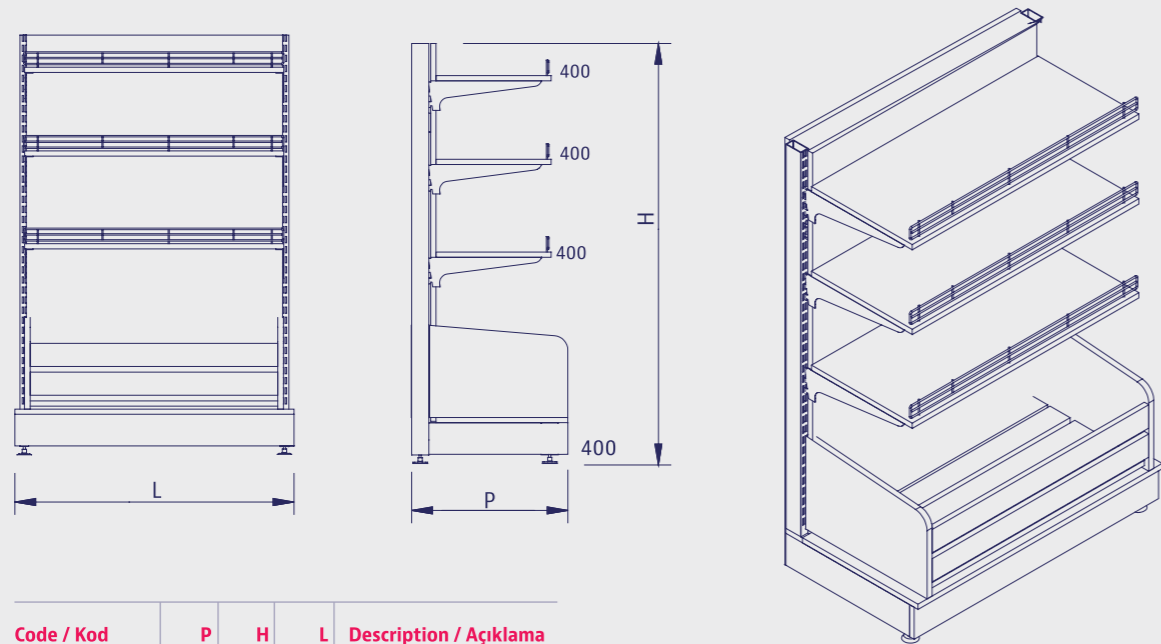

Code / Kod	P	H	L	Description / Açıklama
14A0000042U	400	1430	700	
14A0000043U	400	1430	900	



BAKERIES
UNLU MAMÜLLER

SORBUS BAKERY UNIT
SORBUS UNLU MAMÜL REYONU

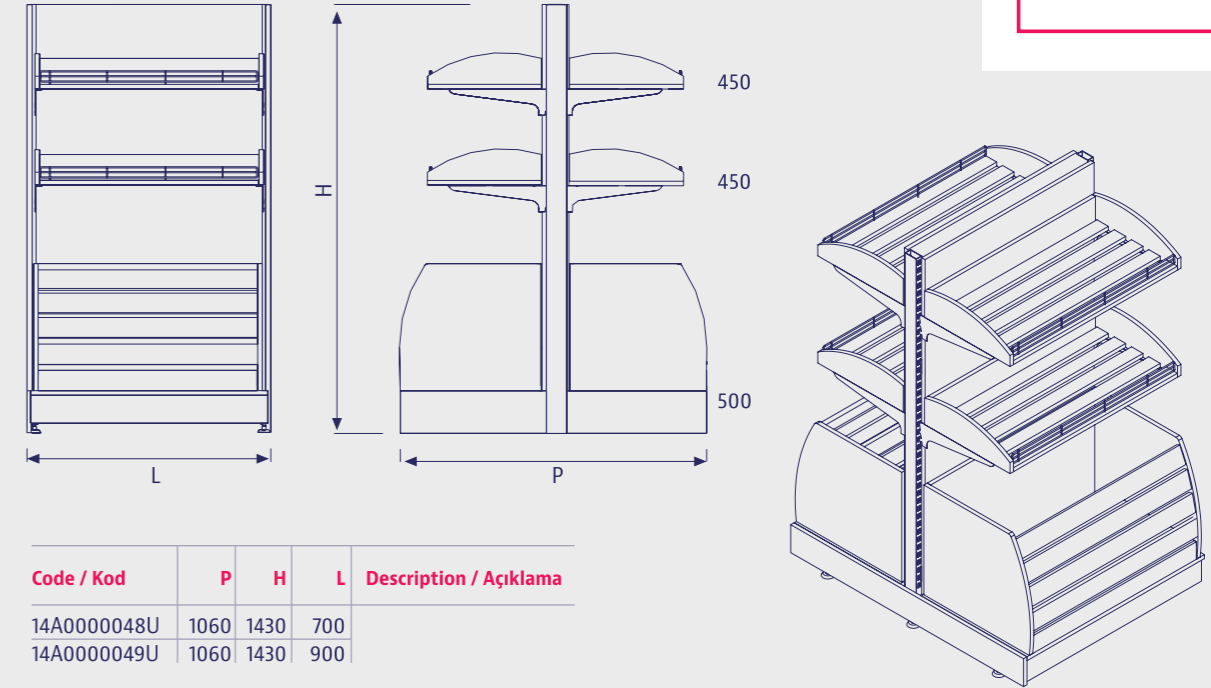

Code / Kod	P	H	L	Description / Açıklama
14A0000048U	1060	1430	700	
14A0000049U	1060	1430	900	

ERICA BAKERY UNIT
ERICA UNLU MAMÜL REYONU

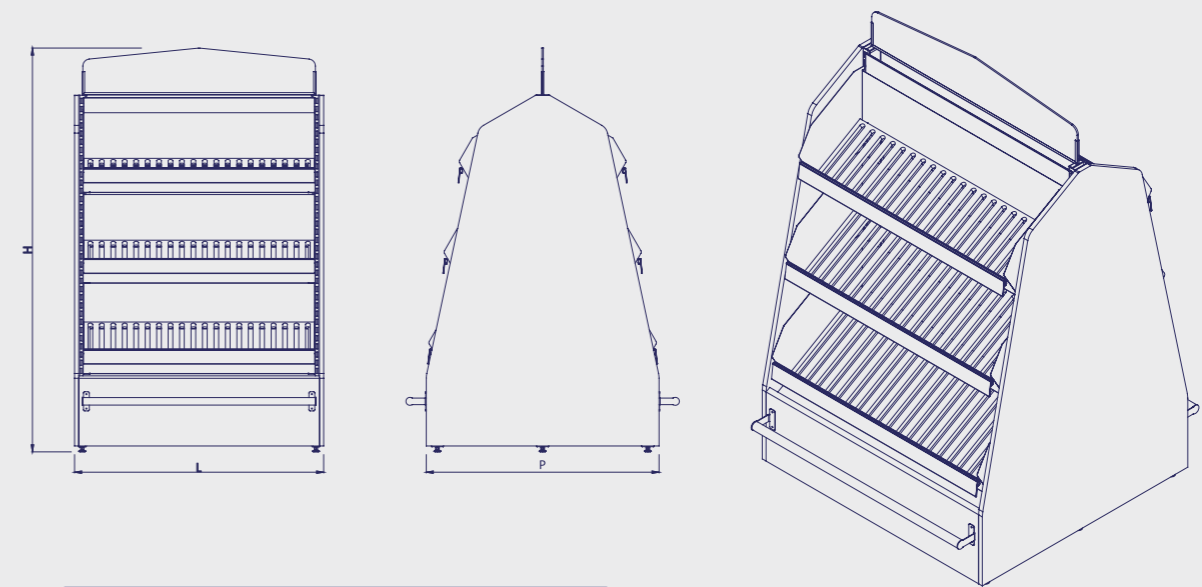

Code / Kod	P	H	L	Description / Açıklama
14A0000096U	996	1726	1066	



BAKERIES
UNLU MAMÜLLER

PUNICA BAKERY UNIT
PUNICA UNLU MAMÜL REYONU

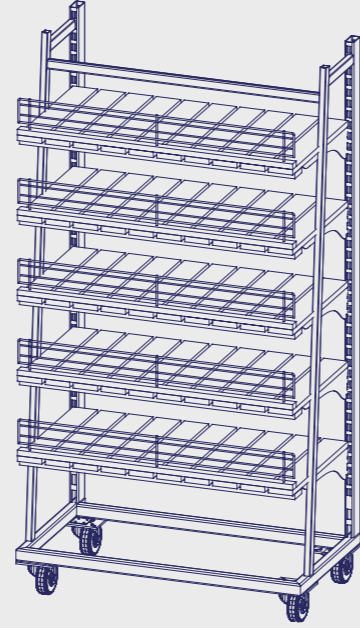
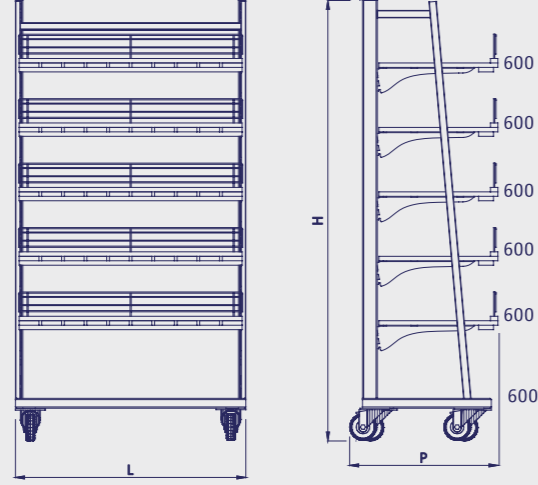

Code / Kod	P	H	L	Description / Açıklama
14A0000104U	600	1770	930	

SPAR POCKET BAKERY UNIT
SPAR UNLU MAMÜL PAKET EKMEK REYONU

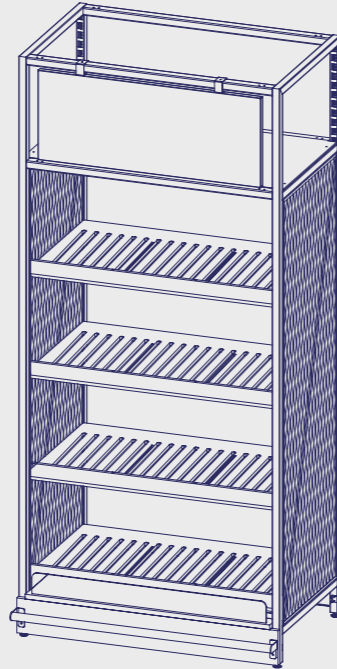
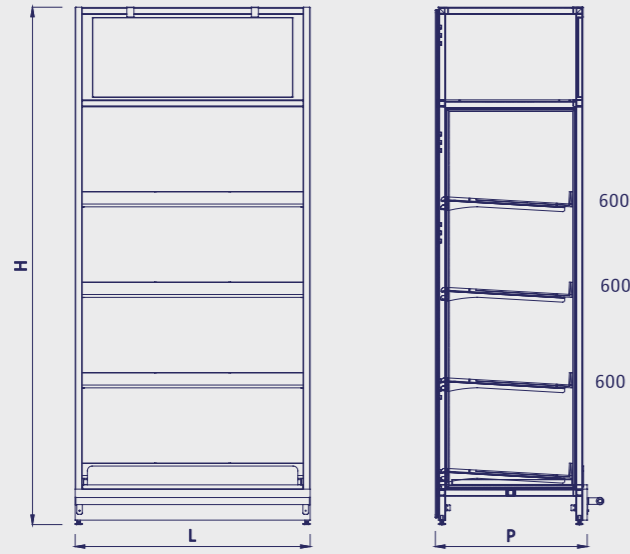

Code / Kod	P	H	L	Description / Açıklama
14A0000091U	615	2200	1000	

SAFARİ BAKERY UNIT
SAFARİ UNLU MAMÜL REYONU

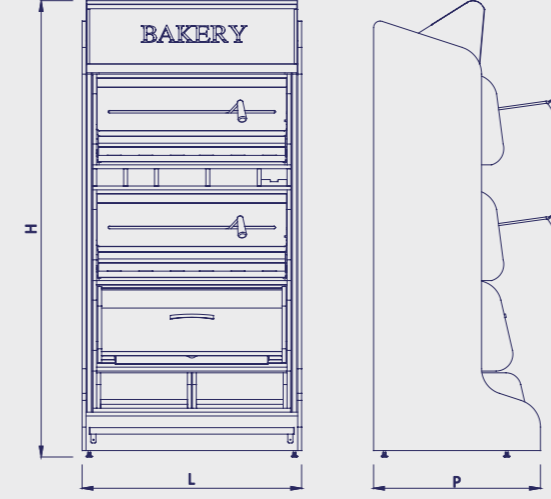

Code / Kod	P	H	L	Description / Açıklama
14A0000102U	773	2112	1017	

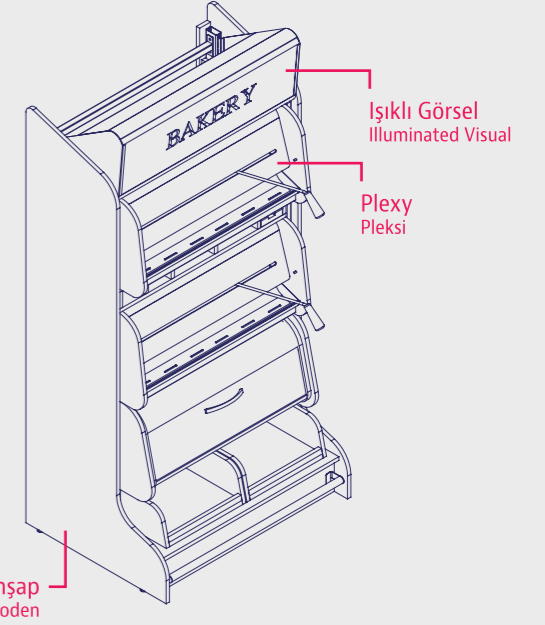

NİGRUM BAKERY UNIT
NİGRUM UNLU MAMÜL REYONU

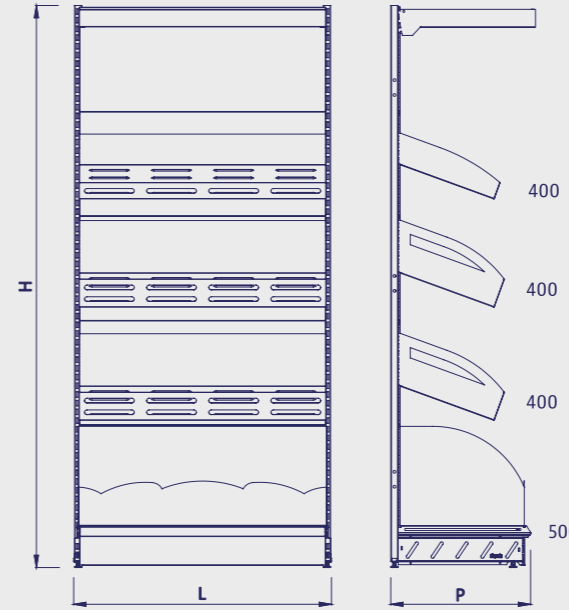

Code / Kod	P	H	L	Description / Açıklama
14A0000103U	560	2270	1000	

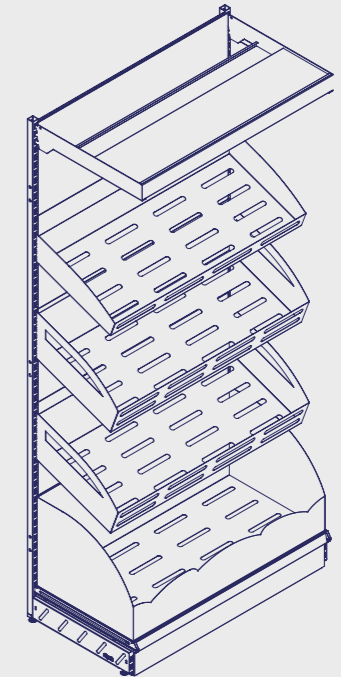



BAKERIES
UNLU MAMÜLLER

VIVA BAKERY UNIT
VIVA UNLU MAMÜL REYONU - ISITICILI

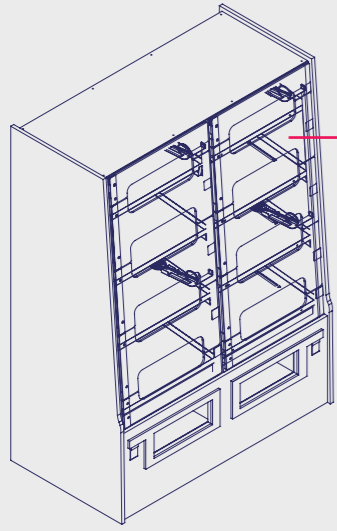

Glass Cover
Cam Kapak

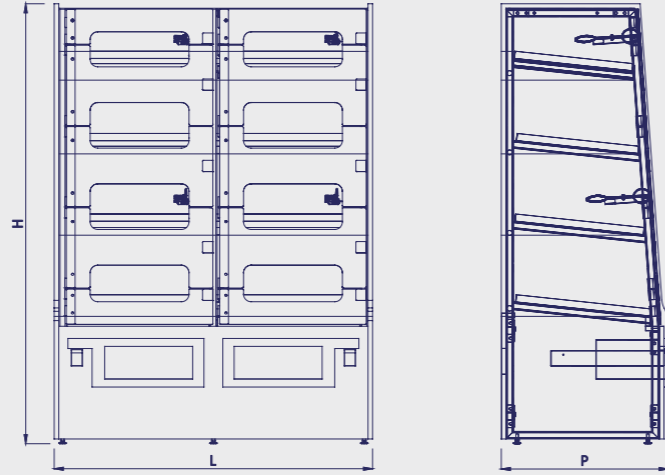

Code / Kod	P	H	L	Description / Açıklama
14A0000085U	640	1730	1266	Isıticılı
14A0000084U	640	1730	1266	Isıticısız Müşteri isteğine göre arkası kapaklı yapılabilmektedir.

AVENA BAKERY UNIT
AVENA UNLU MAMÜL REYONU

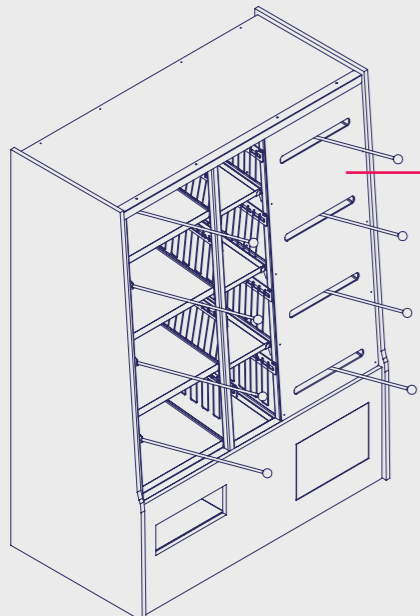

Glass Cover
Cam Kapak

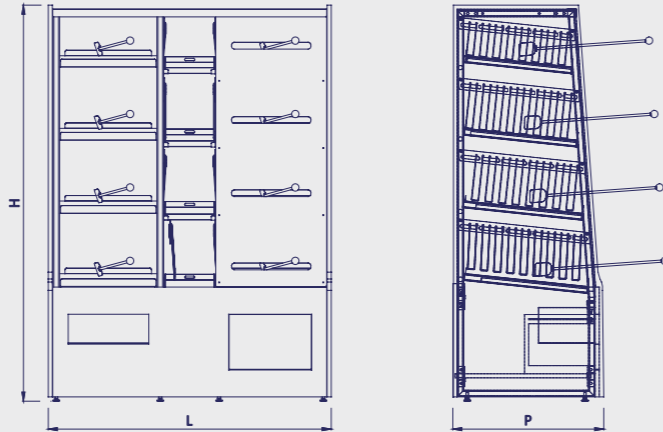

Code / Kod	P	H	L	Description / Açıklama
14A0000083U	667	1750	1250	Isıticılı
14A0000082U	667	1750	1250	Isıticısız



BAKERIES
UNLU MAMÜLLER

BAKERY WALL UNIT
DUVARA MONTE UNLU MAMÜL

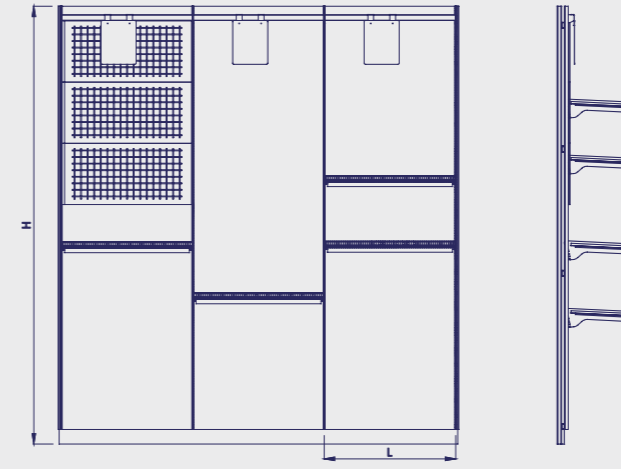

01
Aluminium Profile
Alüminyum Ahşap Profili

02
Wooden Back Panel
Ahşap Arka Pano

03
Rear Bar
Askı Tutucu

04
Wire Shelf
Tel Raf

05
Special Back Panel
Özel Arka Pano

06
Markerboard
Yazı Levhası

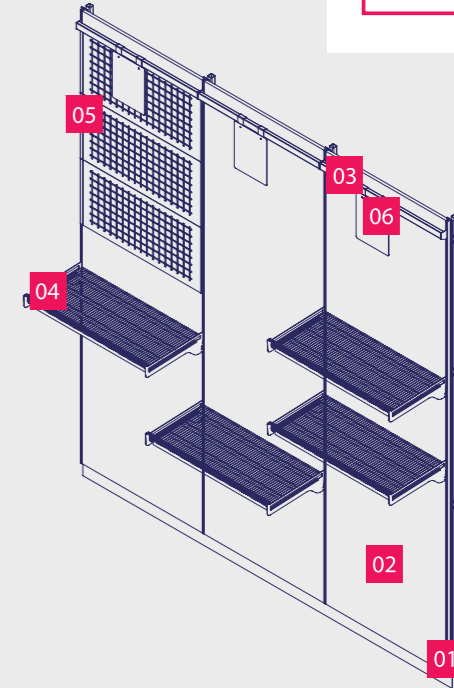

SPAR BAKERY UNIT
SPAR UNLU MAMÜL KAPAKLI

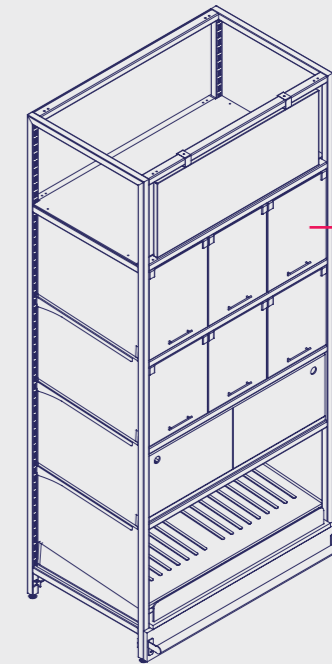
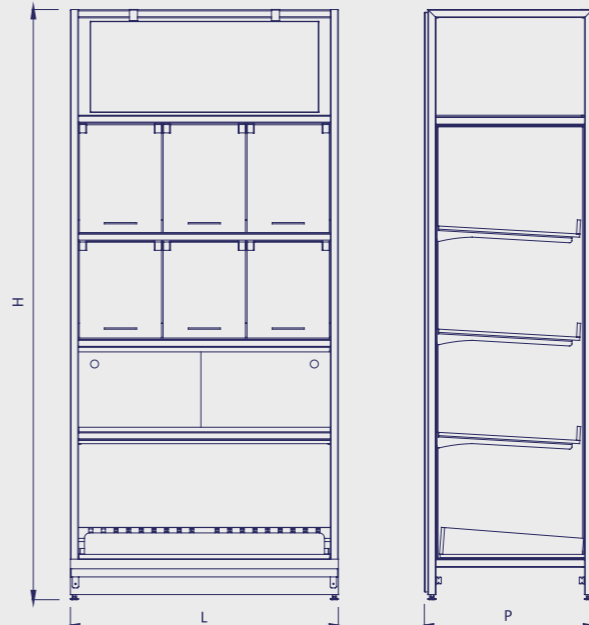

Plexy Cover
Pleksi Kapak

Code / Kod	P	H	L	Description / Açıklama
14A0000095U	630	2200	1000	



BAKERIES
UNLU MAMÜLLER

MARANTA BAKERY UNIT
MARANTA UNLU MAMÜL REYONU

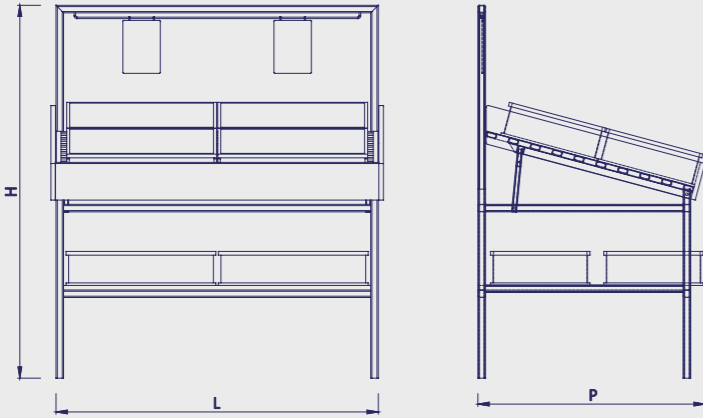

Code / Kod	P	H	L	Description / Açıklama
14A0000105U	900	1480	1280	

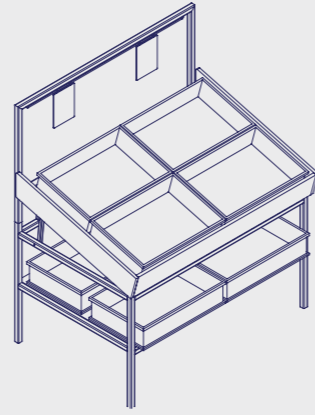

Wooden Basket
Ahşap Kasa

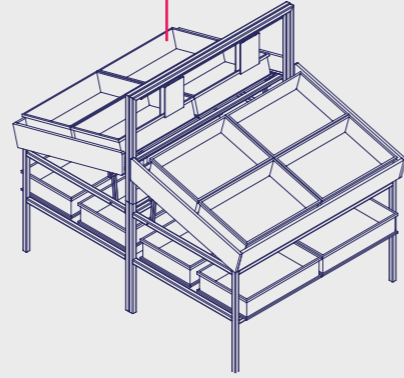

MARANTA BAKERY UNIT
MARANTA DÜZ UNLU MAMÜL REYONU

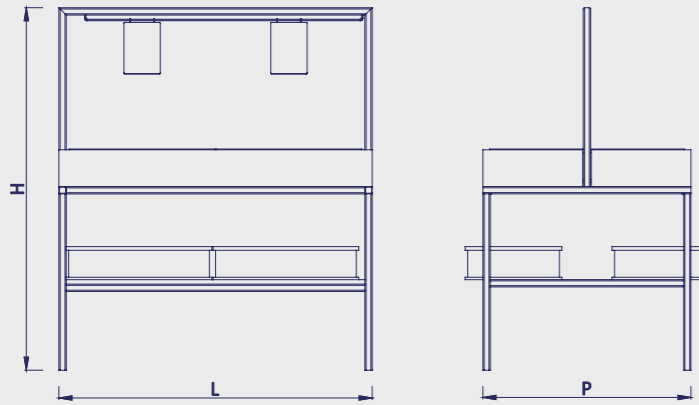

Code / Kod	P	H	L	Description / Açıklama
14A0000106U	850	1480	1280	

Wooden Basket
Ahşap Kasa

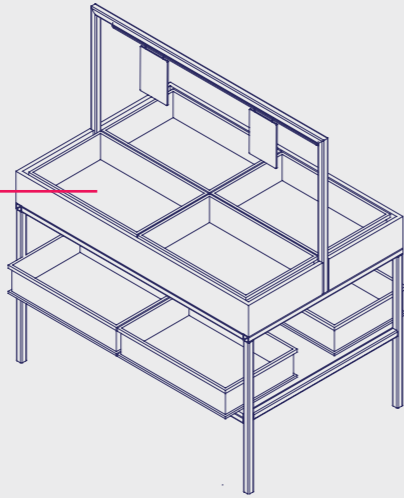

BAKERIES
UNLU MAMÜLLER

PANAX BAKERY UNIT
PANAX UNLU MAMÜL REYONU

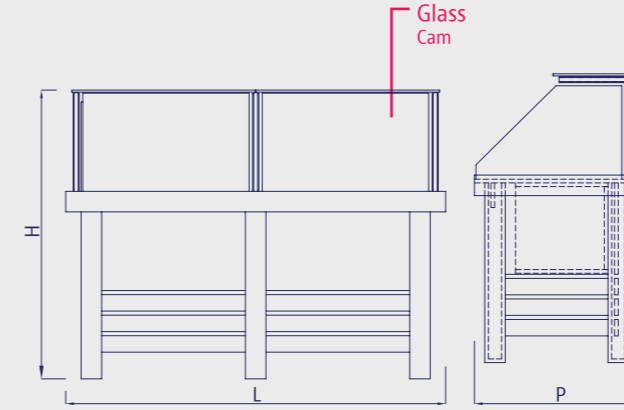

Code / Kod	P	H	L	Description / Açıklama
14A0000015U	800	1400	1850	

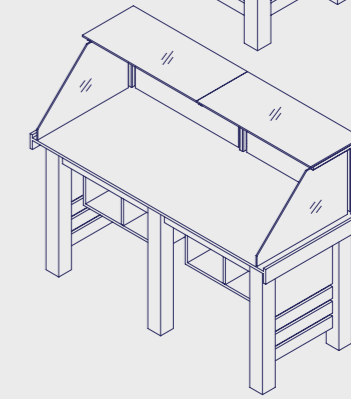
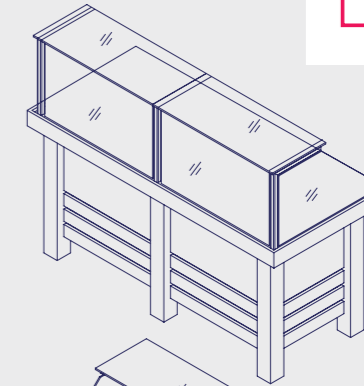

CETRUS BAKERY UNIT
CETRUS UNLU MAMÜL REYONU

Code / Kod	P	H	L	Description / Açıklama
14A0000014U	1560	1260	1290	

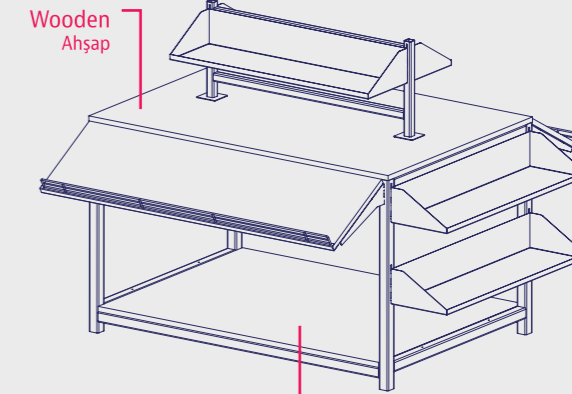

Wooden
Ahşap

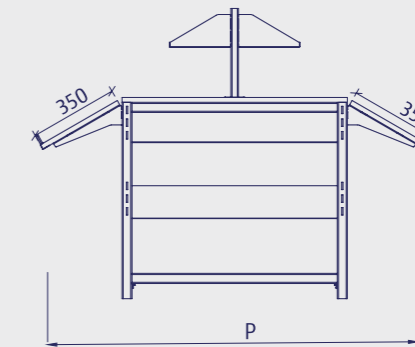
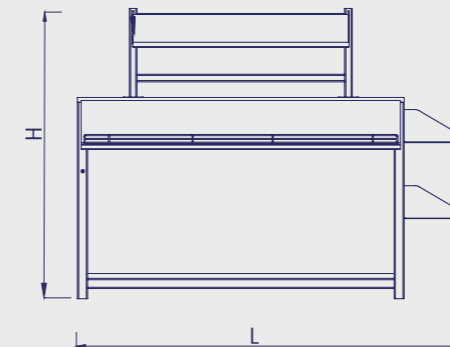



BAKERIES
UNLU MAMÜLLER

WORKTABLE WITH CORIAN TOP
ÇALIŞMA TEZGAHI-ÜSTÜ CORIAN KAPLI

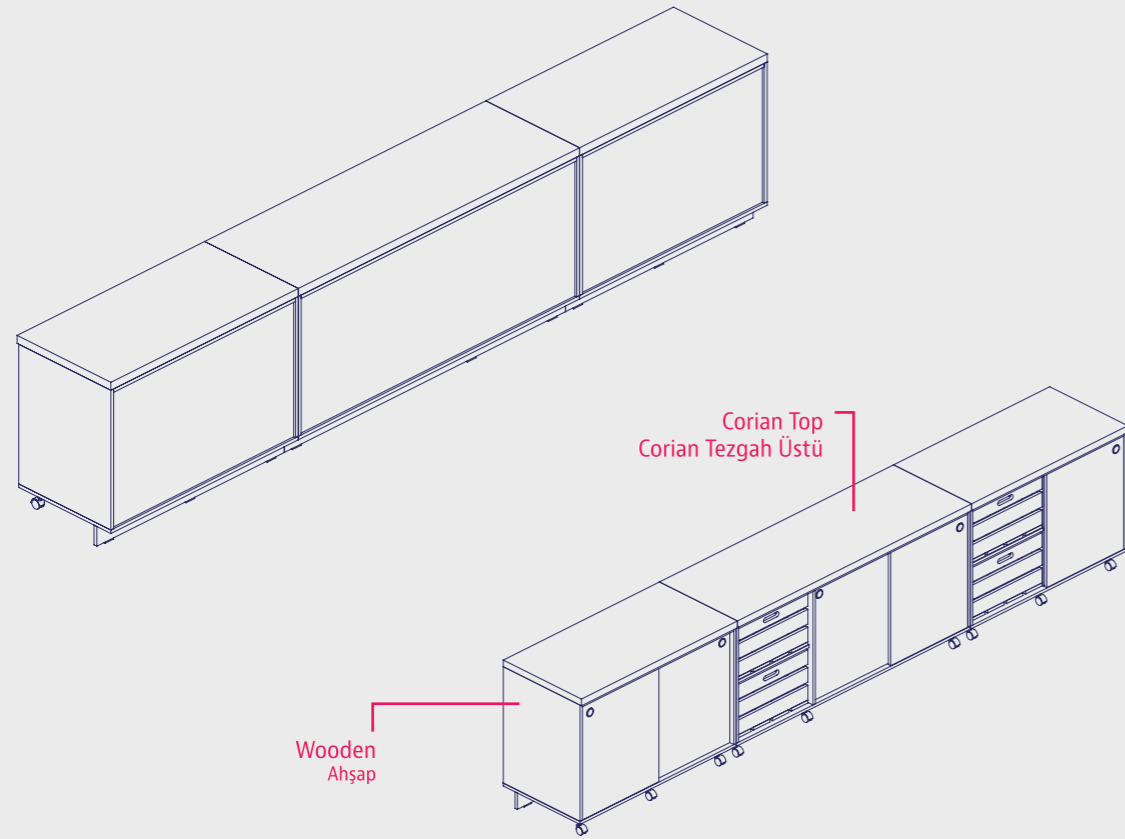
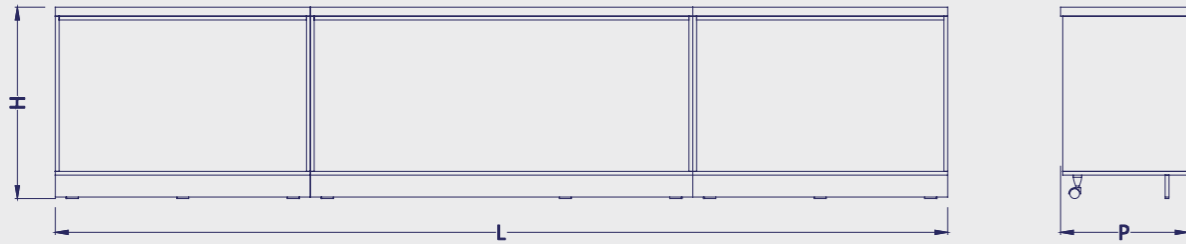

Code / Kod	P	H	L	Description / Açıklama
14B0000032U	600	900	4200	* L can be change according to project * L uzunluğu projeye göre değişebilir.



BAKERIES
UNLU MAMÜLLER

WORKTABLE WITH CORIAN TOP
ÇALIŞMA TEZGAHI-ÜSTÜ CORIAN KAPLI -Lavabolu

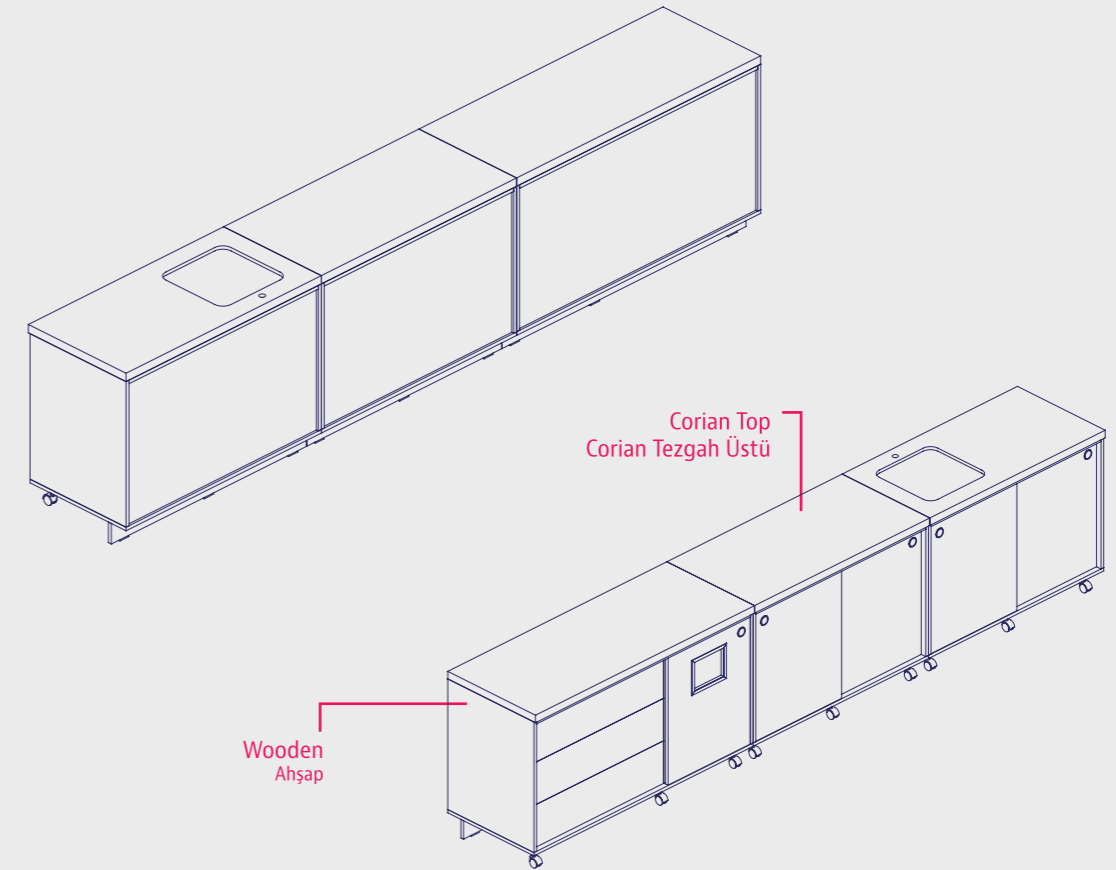
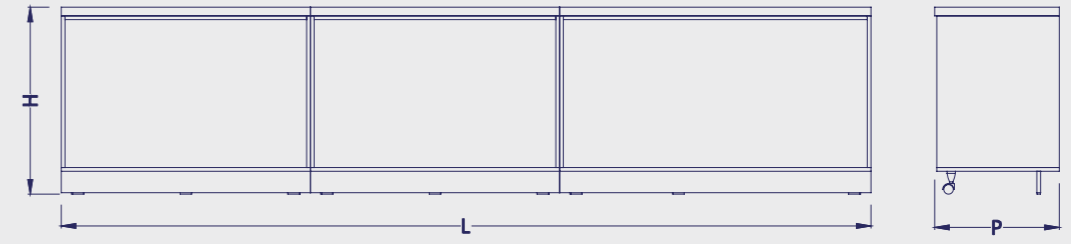

Code / Kod	P	H	L	Description / Açıklama
14B0000018U	600	900	3900	Sağ
14B0000017U	600	900	3900	Sol L uzunluğu projeye göre değişiklik gösterebilir.



**FRUIT &
VEGETABLE UNIT**

**MEYVE VE
SEBZE REYONU**



**FRUIT &
VEGETABLE
UNIT**
MEYVE VE
SEBZE REYONU

MARS FRUIT & VEGETABLE WALL UNIT
MARS MEYVE SEBZE DUVAR REYONU

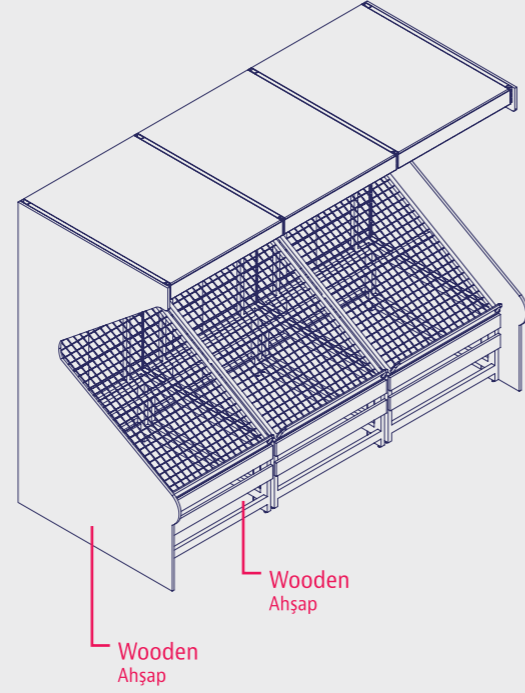
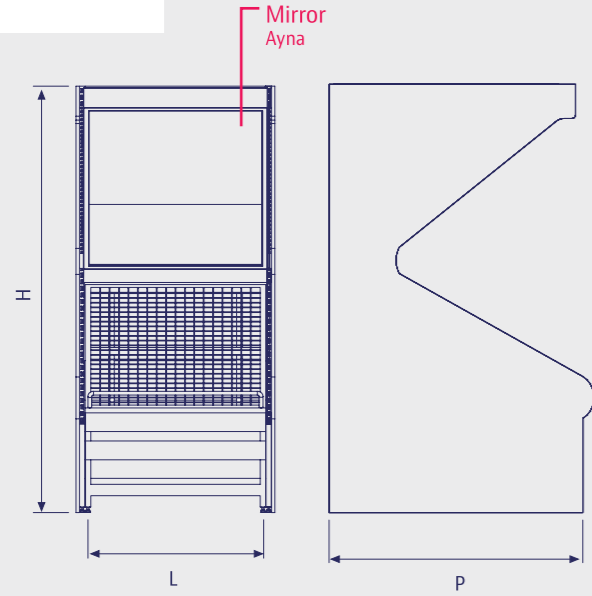

Code / Kod	P	H	L	Description / Açıklama
15A0000001U	1200	2270	1000	Wooden Side Cover
15A0000002U	1200	2270	1250	Yan kapamaları Ahşap

VENUS FRUIT & VEGETABLE WALL UNIT
VENUS MEYVE SEBZE DUVAR REYONU

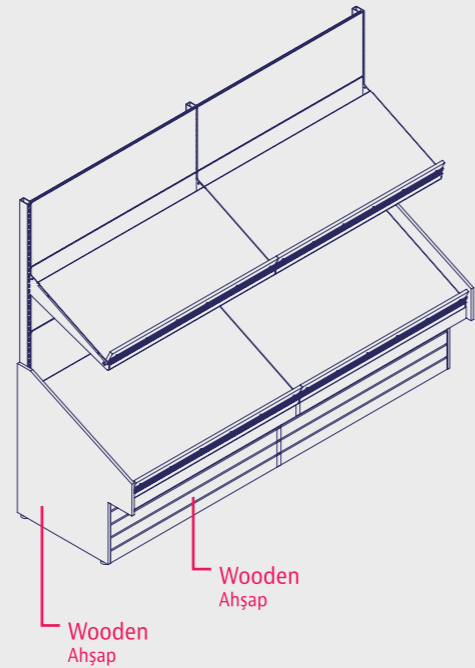
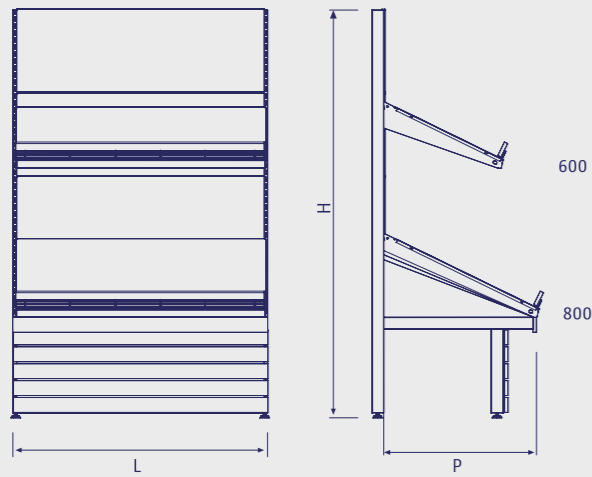

Code / Kod	P	H	L	Description / Açıklama
15B0000001U	800	2060	1000	Wooden Side Cover
15B0000002U	800	2060	1250	Yan kapamaları Ahşap
15B0000003U	800	2270	1000	
15B0000004U	800	2270	1250	



**FRUIT &
VEGETABLE
UNIT**
MEYVE VE
SEBZE REYONU

HALLEY FRUIT & VEGETABLE WALL UNIT
HALLEY MEYVE SEBZE DUVAR REYONU

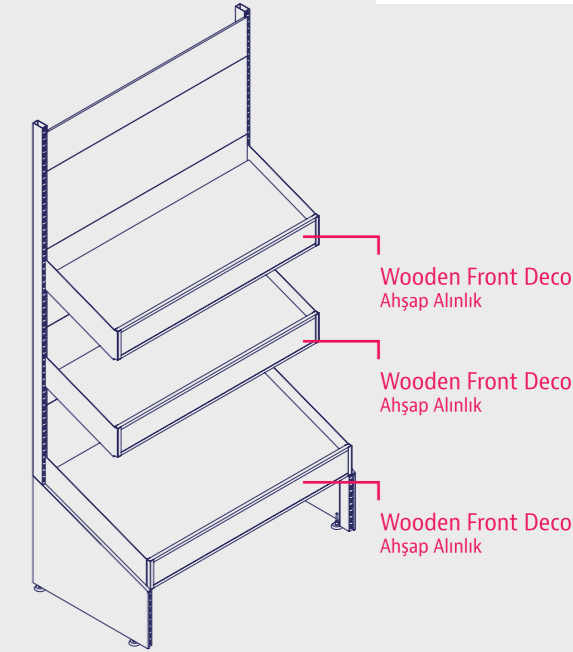
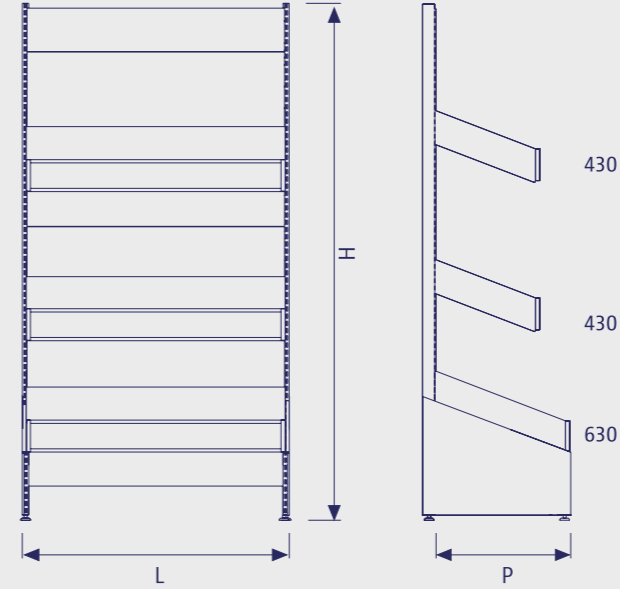

Code / Kod	P	H	L	Description / Açıklama
15C0000001U	630	2270	1250	For 7pcs F&V basket 7 adet sepet için

HALLEY FRUIT & VEGETABLE WALL UNIT WITH MIRROR
HALLEY MEYVE SEBZE DUVAR REYONU - AYNALI

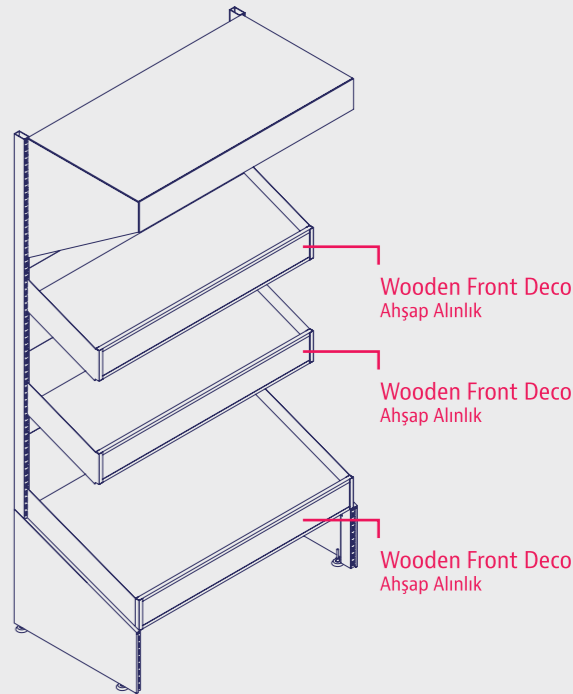
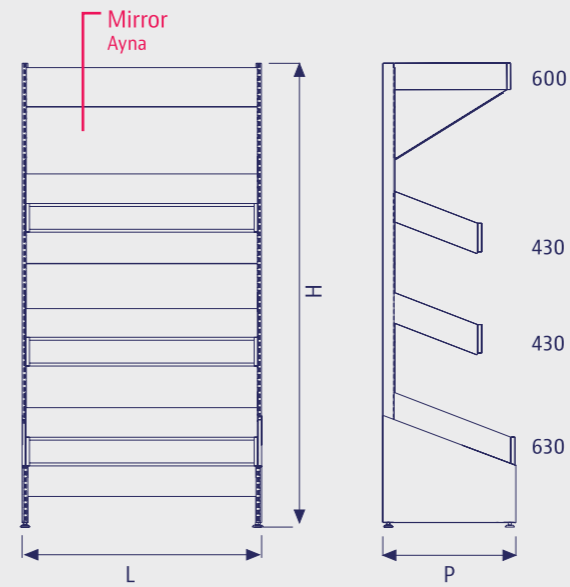

Code / Kod	P	H	L	Description / Açıklama
15C0000002U	630	2270	1250	For 7pcs F&V basket 7 adet sepet için



**FRUIT &
VEGETABLE
UNIT**
MEYVE VE
SEBZE REYONU

VEGA FRUIT & VEGETABLE WALL UNIT
VEGA MEYVE SEBZE DUVAR REYONU

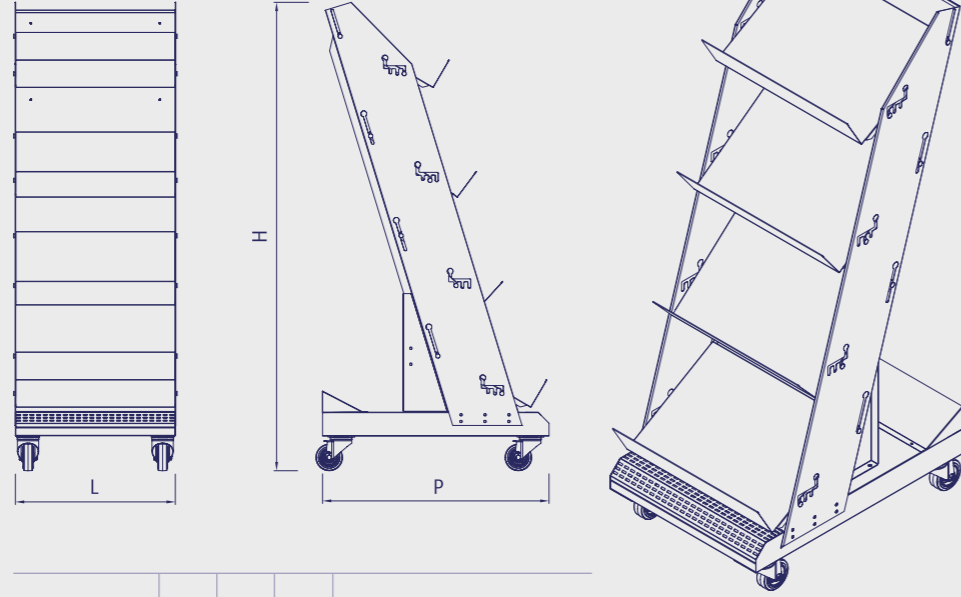

Code / Kod	P	H	L	Description / Açıklama
15D0000001U	850	1750	600	Painted / Boyalı
15D0000002U	850	1750	600	Stainless Steel / Paslanmaz

PEGASUS FRUIT & VEGETABLE WALL UNIT
PEGASUS MEYVE SEBZE DUVAR REYONU

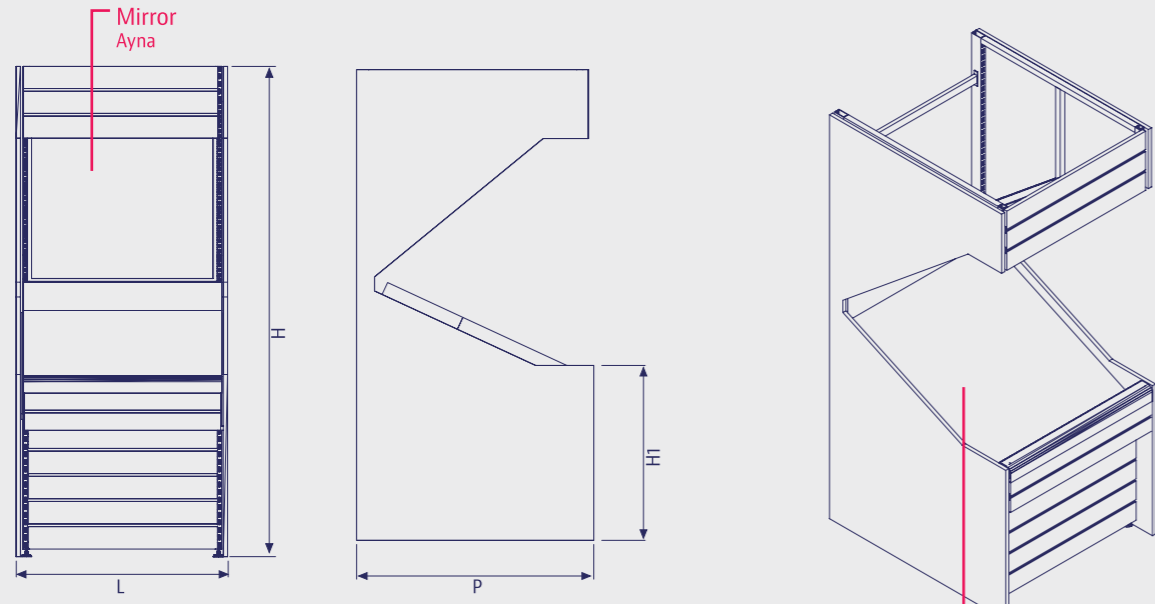

Code / Kod	P	H	H1	L	Description / Açıklama
15E0000001U	1290	2270	850	1000	Painted or Stainless Steel Option
15E0000002U	1290	2270	850	1250	Boya ve Paslanmaz Opsiyonlu

Stainless Steel
Paslanmaz

ALGO FRUIT & VEGETABLE UNIT
ALGO SEBZE REYONU

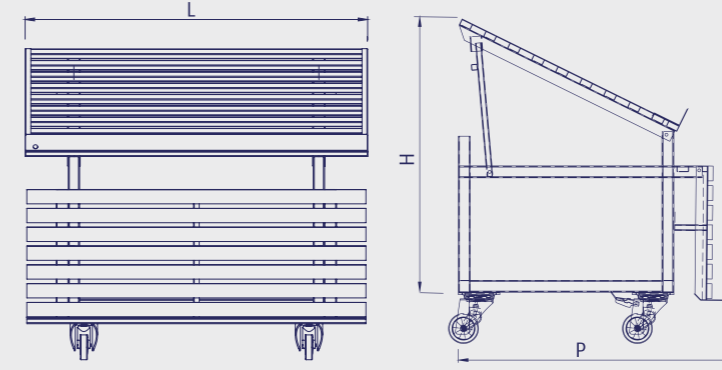

Code / Kod	P	H	L	Description / Açıklama
97000000082	925	1100	1200	

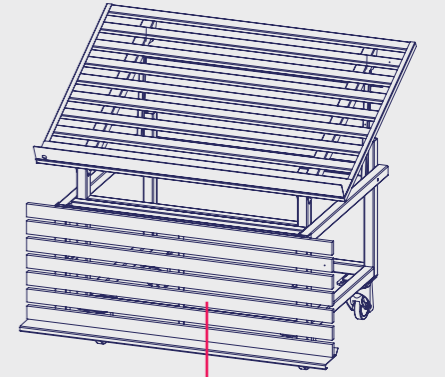

Wooden
Ahşap

ANTA FRUIT & VEGETABLE UNIT
ANTA MEYVE SEBZE REYONU

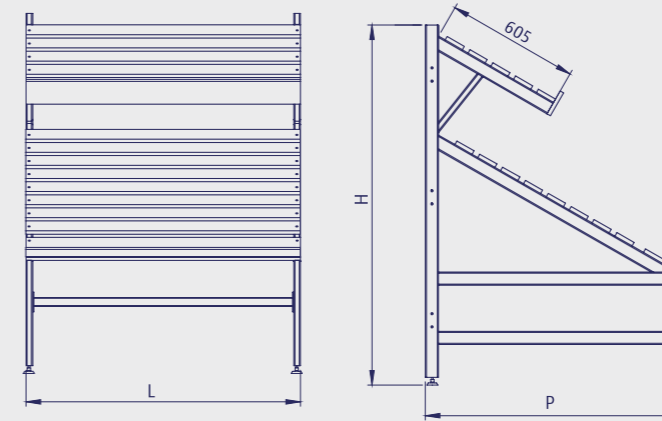

Code / Kod	P	H	L	Description / Açıklama
15G0000001U	1150	1640	1250	

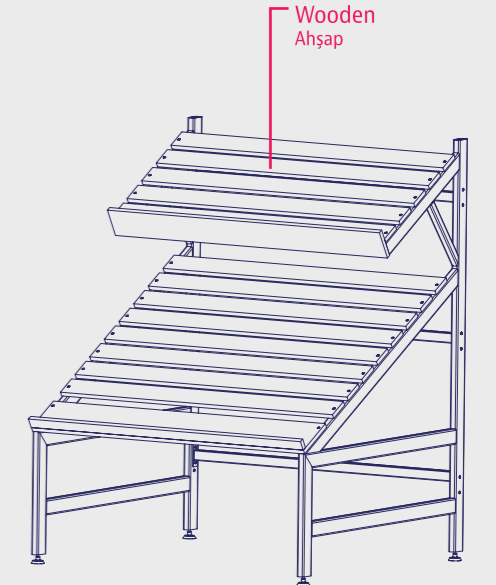

Wooden
Ahşap



**FRUIT &
VEGETABLE
UNIT**
MEYVE VE
SEBZE REYONU

ORION FRUIT & VEGETABLE GONDOLA UNIT
ORION MEYVE SEBZE ORTA REYON

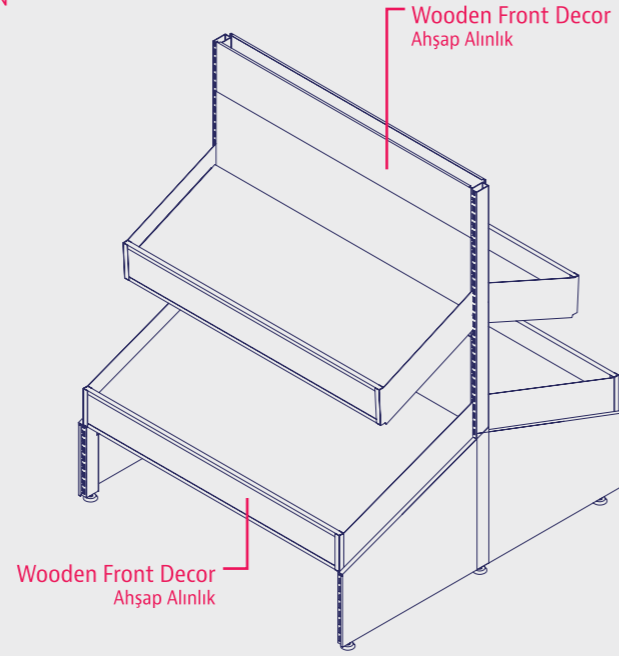
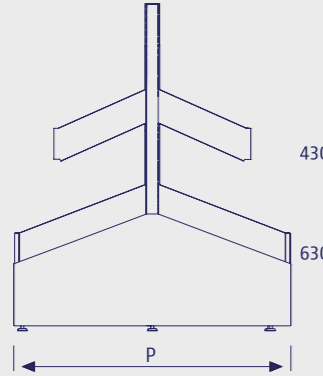
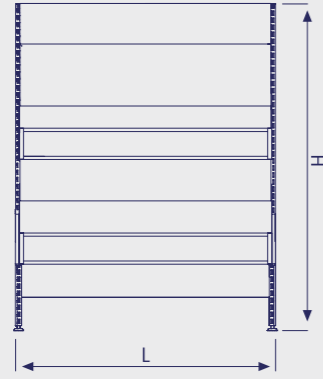

Code / Kod	P	H	L	Description / Açıklama
15C000003U	1320	1640	1250	For 10pcs F&V basket 10 adet sepet için

AURA FRUIT & VEGETABLE GONDOLA UNIT
AURA MEYVE SEBZE ORTA REYON

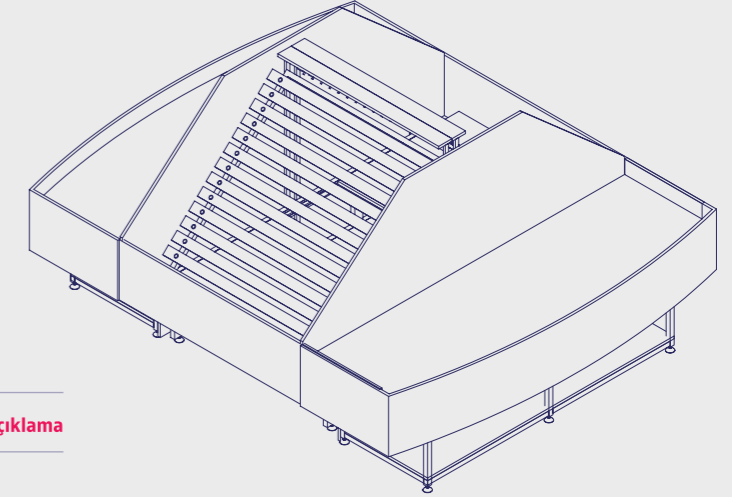
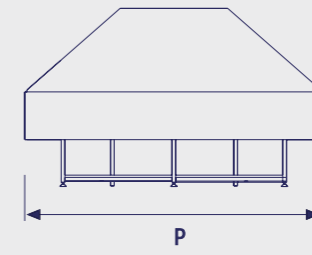
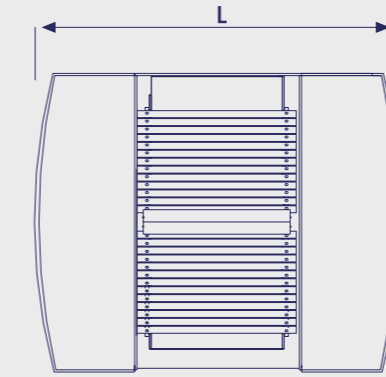
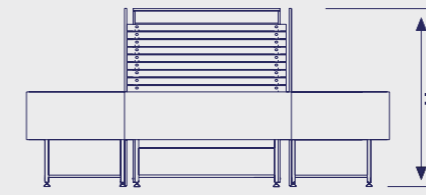

Code / Kod	P	H	L	Description / Açıklama
15J000001U	2400	1335	2500	

SOLAR FRUIT & VEGETABLE UNIT
SOLAR MEYVE SEBZE REYONU

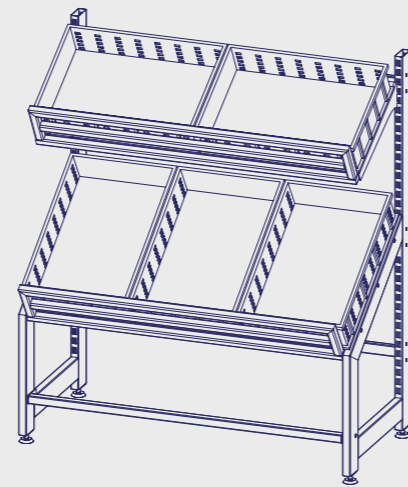
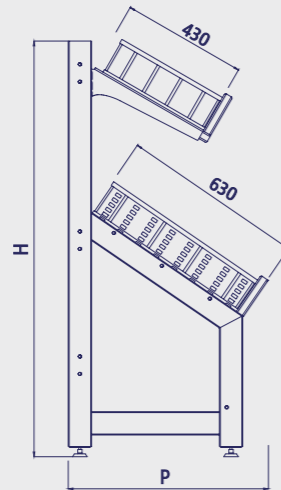
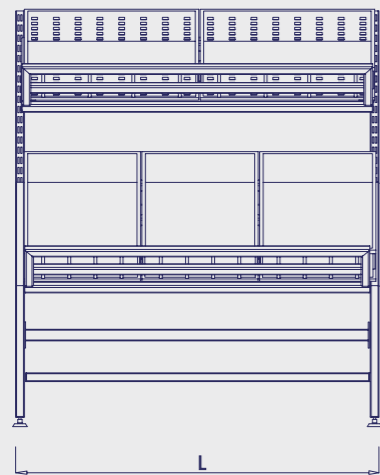

Code / Kod	P	H	L	Description / Açıklama
15I0000001U	690	1430	1250	For 5 pcs F&V basket 5 adet sepet için

CASTOR FRUIT & VEGETABLE UNIT
CASTOR MEYVE SEBZE REYONU

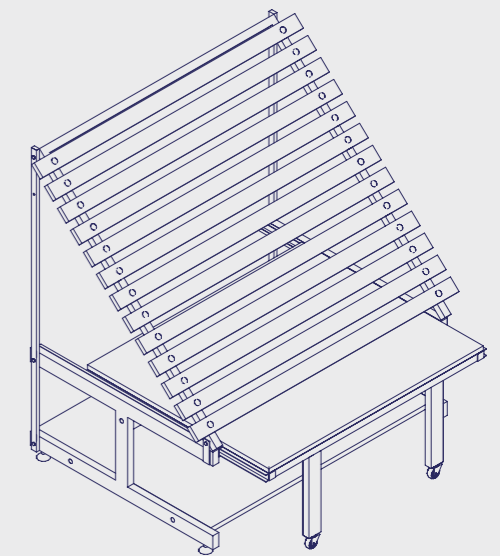
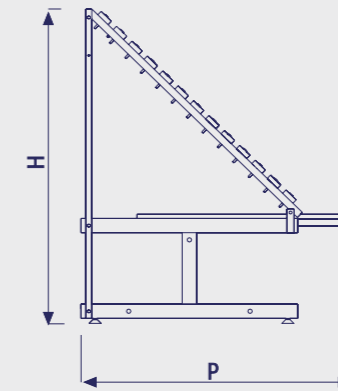
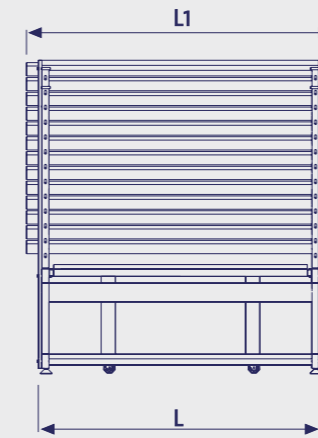

Code / Kod	P	H	L	L1	Description / Açıklama
15K0000001U	1200	1335	1200	1300	



**FRUIT &
VEGETABLE
UNIT**
MEYVE VE
SEBZE REYONU

POLLUX FRUIT & VEGETABLE GONDOLA UNIT
POLLUX MEYVE SEBZE ORTA REYON

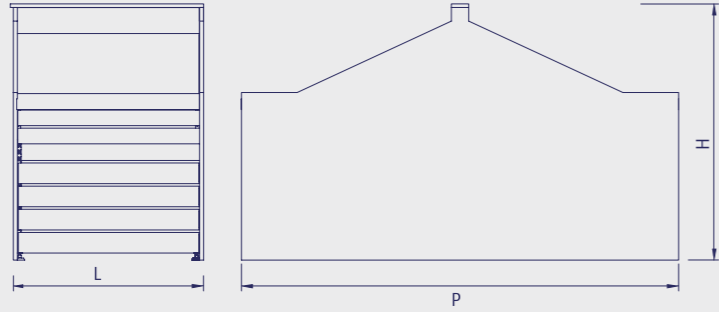

Code / Kod	P	H	L	Description / Açıklama
15L0000001U	2200	1250	700	
15L0000002U	2200	1250	900	
15L0000003U	2200	1250	1000	
15L0000004U	2200	1250	1250	

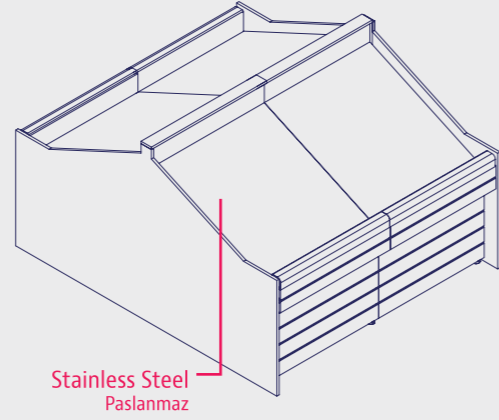

EARTH FRUIT & VEGETABLE GONDOLA UNIT
EARTH MEYVE SEBZE ORTA REYON

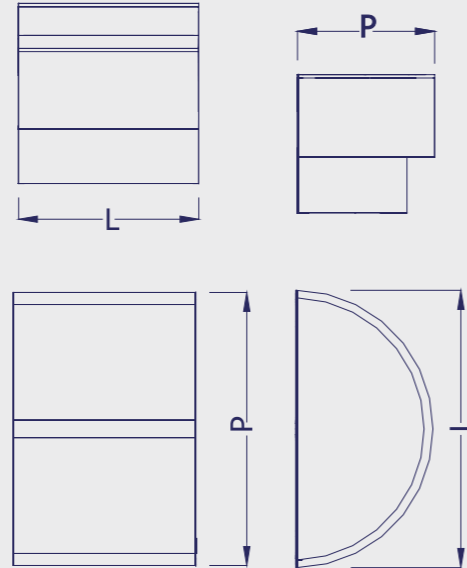
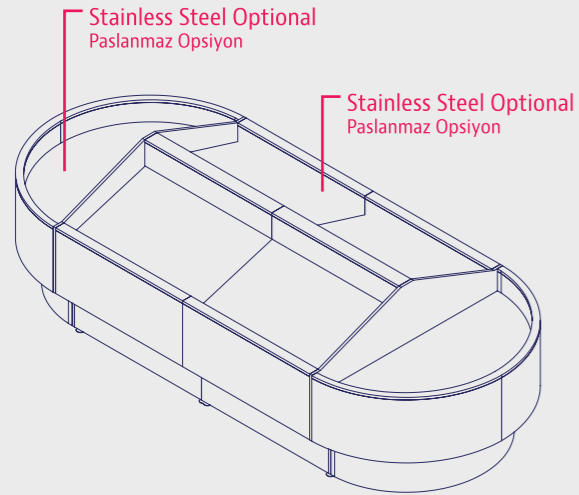

Code / Kod	P	H	L	Description / Açıklama
15M0000001U	950	1850		Earth Gondola Head / EarthGondolbaşı
15M0000002U	1850	1200		Earth Gondola / Earth Orta Reyon

* Length may change depending on project.
* Uzunluk ölçüsü projeye göre değişebilir.



**FRUIT &
VEGETABLE
UNIT**
MEYVE VE
SEBZE REYONU

STAR FRUIT & VEGETABLE GONDOLA UNIT
STAR MEYVE SEBZE ORTA REYON

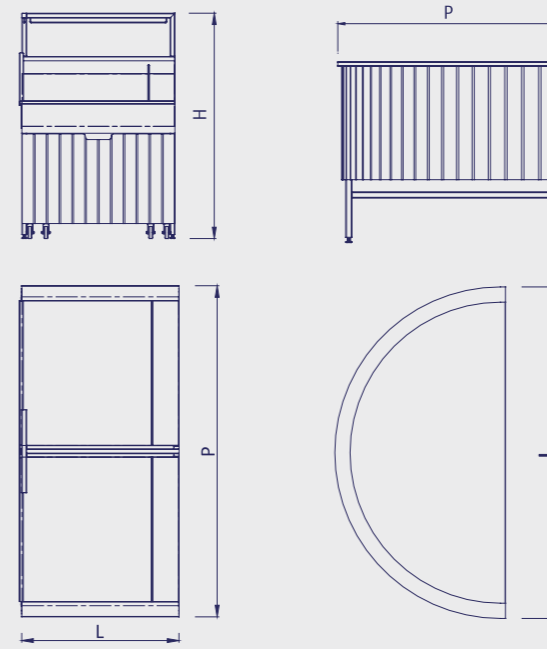

Code / Kod	P	H	L	Description / Açıklama
15N0000003U	1000	2000		Star Gondola Head / StarGondolbaşı
15N0000004U	2000	950		Star Gondola / Star Orta Reyon

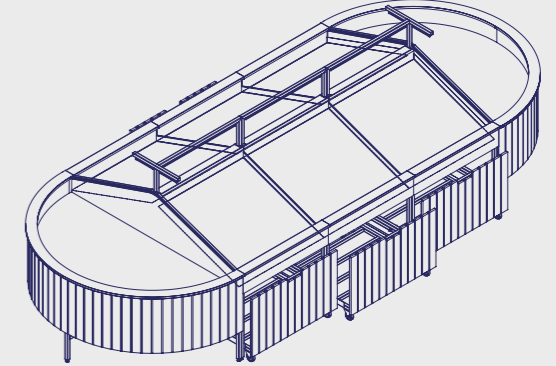

ANTARES FRUIT & VEGETABLE GONDOLA UNIT
ANTARES MEYVE SEBZE ORTA REYON

Code / Kod	P	H	L	Description / Açıklama
15M0000003U	2000	1400	3317	

Wooden Basket
Ahşap Kasa

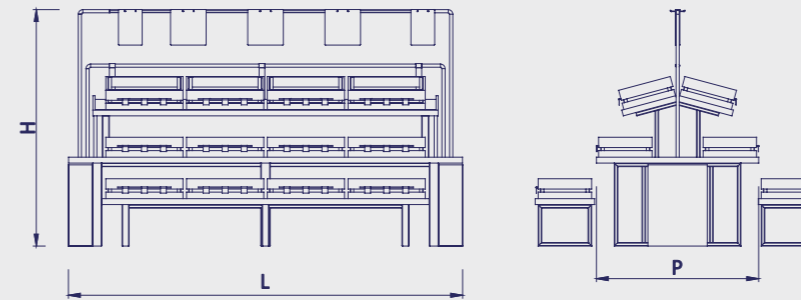
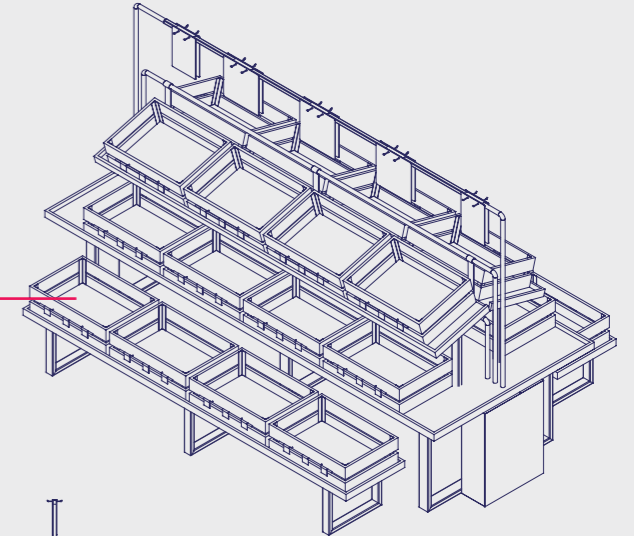



**FRUIT &
VEGETABLE
UNIT**
MEYVE VE
SEBZE REYONU

NEPTUN FRUIT & VEGETABLE ONE SIDED GONDOLA UNIT
NEPTUN MEYVE SEBZE TEK YÖNLÜ ORTA REYON

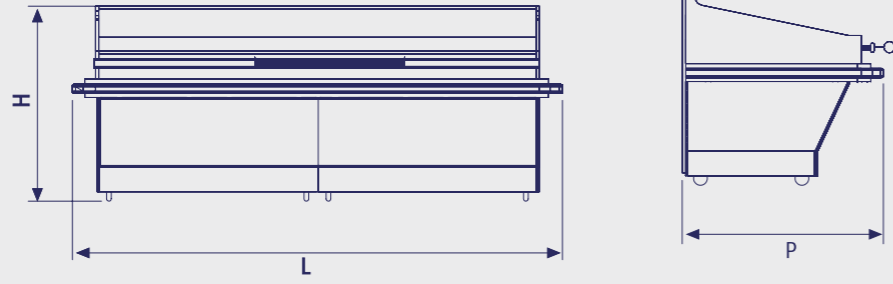

Stainless Steel Optional
Paslanmaz Opsiyon

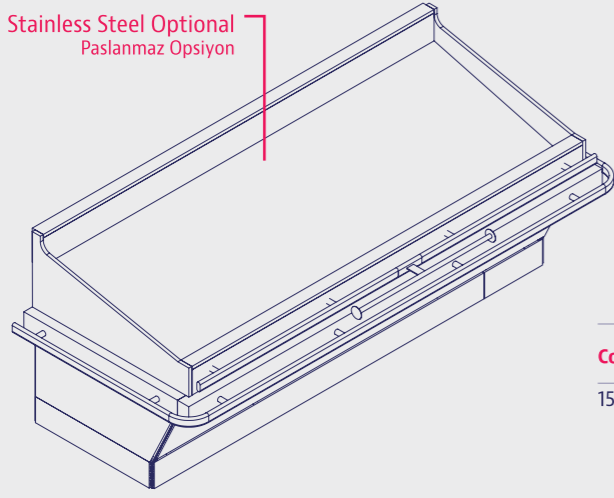

Code / Kod	P	H	L	Description / Açıklama
15P0000001U	1050	1100	2100	Together with wheels Tekerlekli

NEPTUN FRUIT & VEGETABLE DOUBLE SIDED
NEPTUN MEYVE SEBZE ÇİFT YÖNLÜ ORTA REYON

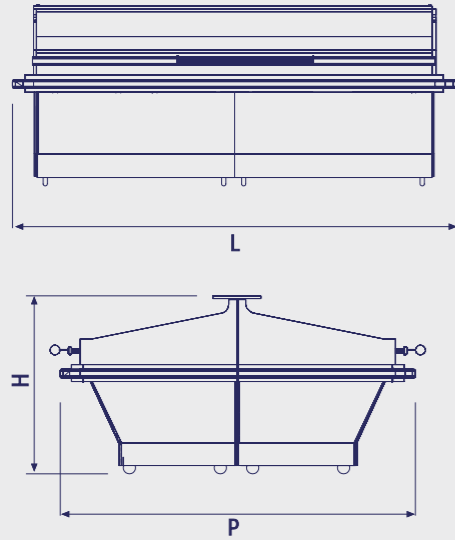

Stainless Steel Optional
Paslanmaz Opsiyon

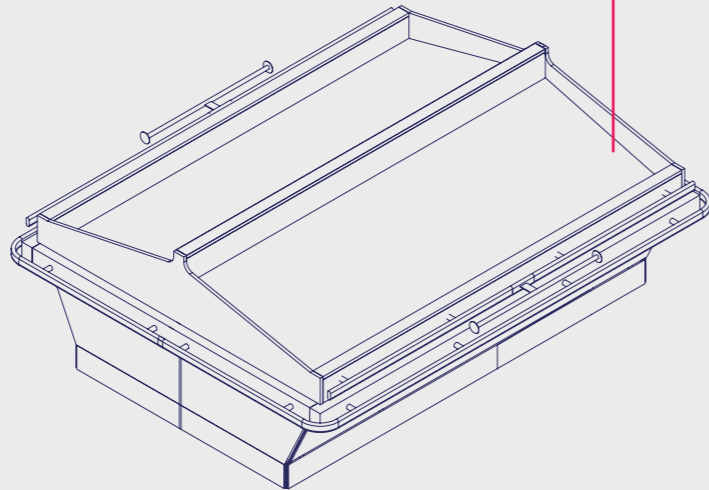

Code / Kod	P	H	L	Description / Açıklama
15P0000002U	2100	1100	2100	Together with wheels Tekerlekli



**FRUIT &
VEGETABLE
UNIT**
MEYVE VE
SEBZE REYONU

RİGEL FRUIT & VEGETABLE WALL UNIT
RİGEL MEYVE SEBZE REYONU

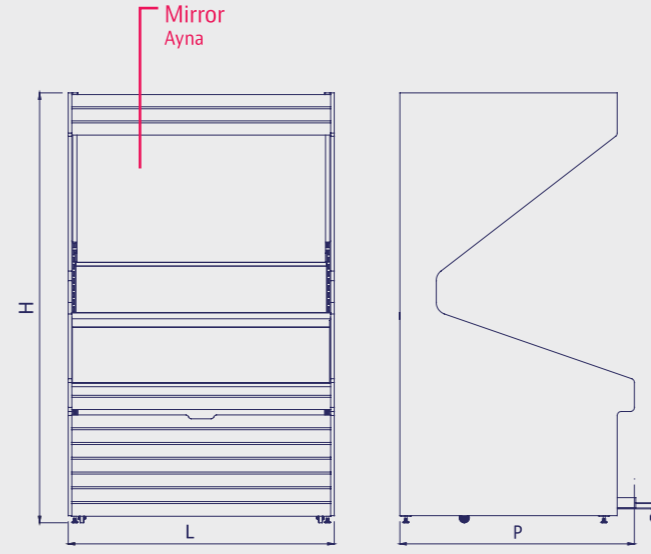

Code / Kod	P	H	L	Description / Açıklama
15E0000004U	1152	2125	1316	

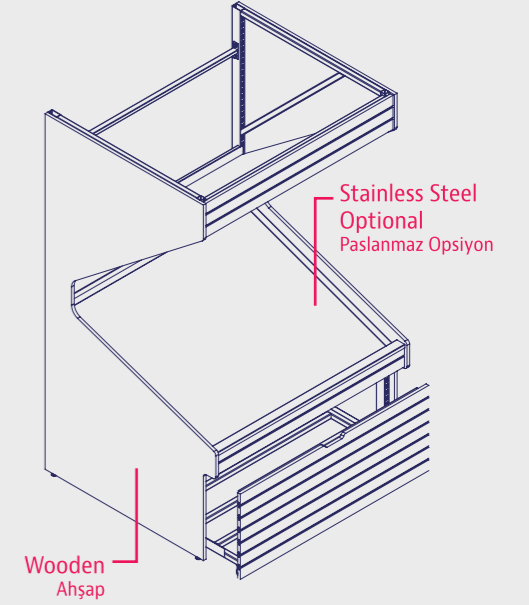

Wooden
Ahşap

AGENA FRUIT & VEGETABLE GONDOLA UNIT
AGENA MEYVE SEBZE ORTA REYON

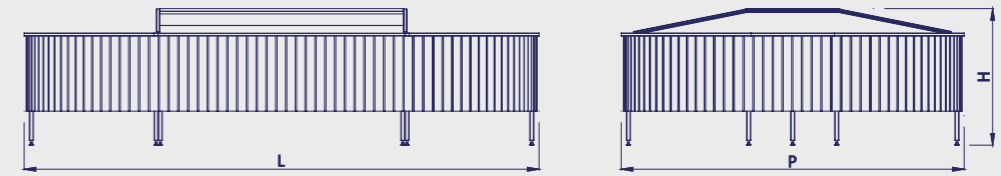

Code / Kod	P	H	L	Description / Açıklama
15M0000004U	2474	985	3700	

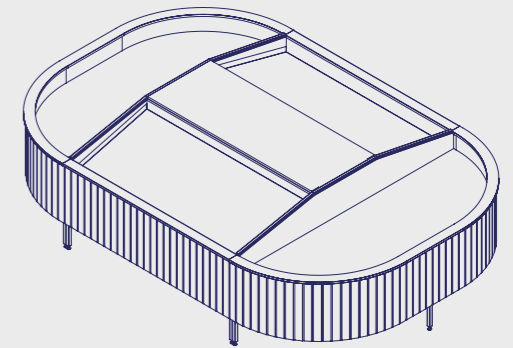



**FRUIT &
VEGETABLE
UNIT**
MEYVE VE
SEBZE REYONU

SPARK FRUIT & VEGETABLE UNIT WITH PROFILE BACK PANEL
SPARK MEYVE SEBZE REYONU - PROFİL ARKA PANOLU

Code / Kod	P	H	L	Description / Açıklama
15D6033004U	1148	1854	1280	

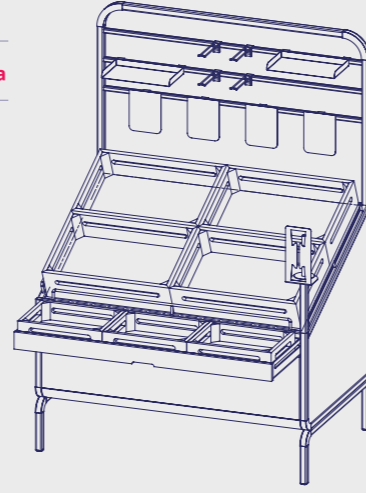
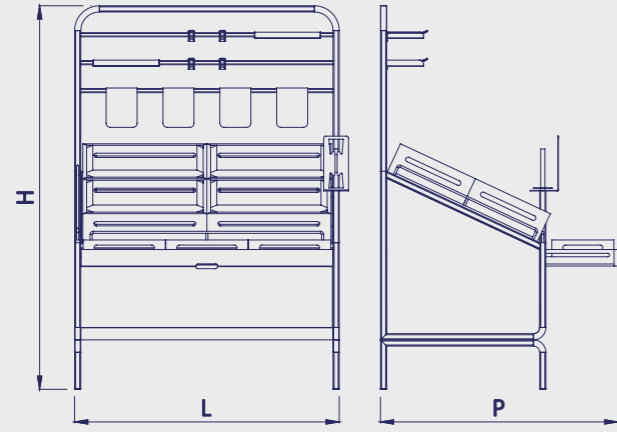

SPARK FRUIT & VEGETABLE UNIT WITH HEADER
SPARK MEYVE SEBZE REYONU - ŞAPKALI

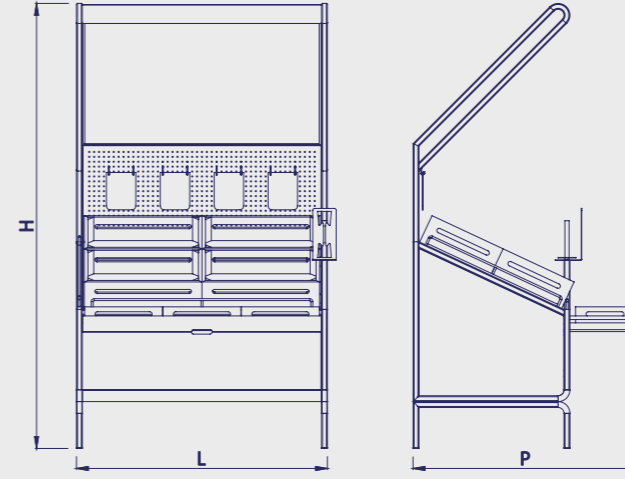

Code / Kod	P	H	L	Description / Açıklama
15D6033005U	1148	2270	1280	

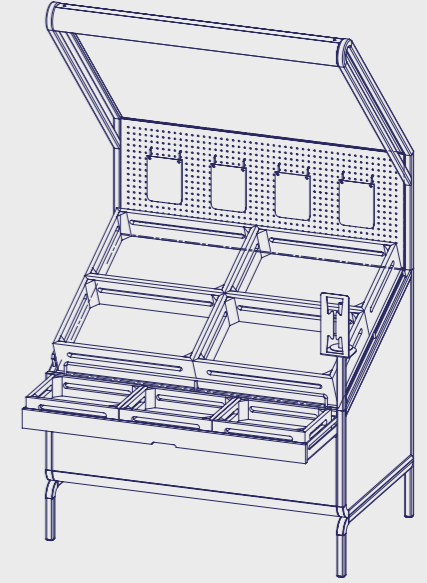

**FRUIT &
VEGETABLE
UNIT**
MEYVE VE
SEBZE REYONU

SPARK FRUIT & VEGETABLE UNIT WITH PERFORATED BACK PANEL
SPARK MEYVE SEBZE REYONU - DELİKLİ ARKA PANOLU

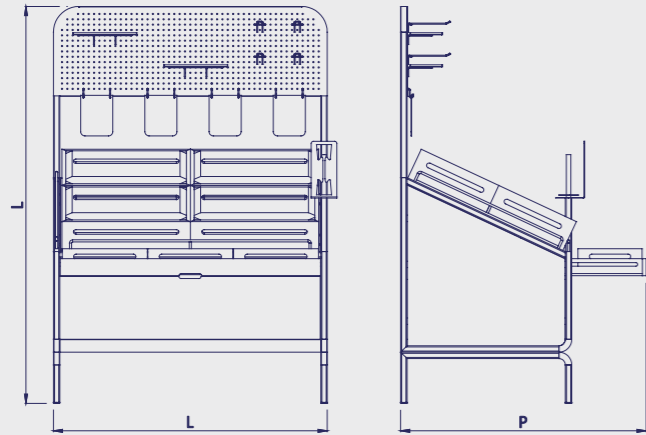

Code / Kod	P	H	L	Description / Açıklama
15D6033003U	1148	1854	1280	

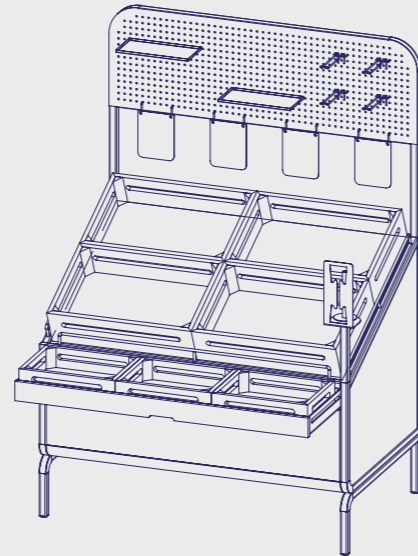

FRUIT & VEGETABLE PLASTIC BASKET
MEYVE SEBZE SEPETİ



Code / Kod	P	H	L	Description / Açıklama
97000000081	400	150	600	



**FRUIT &
VEGETABLE
UNIT**
MEYVE VE
SEBZE REYONU

ORBİT WOODEN TABLE FOR SCALES
ORBİT TERAZİ BANKOSU (TAKIM)

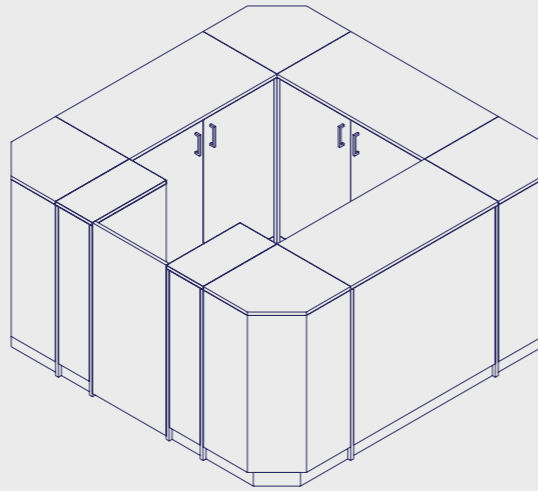
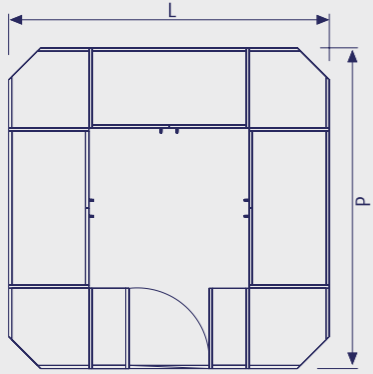
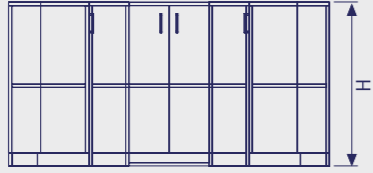

Code / Kod	P	H	L	Description / Açıklama
15U0000001U	2000	1000	2000	

ORTBİT 2 WOODEN TABLE FOR SCALES
ORBİT 2 TERAZİ BANKOSU (TAKIM)

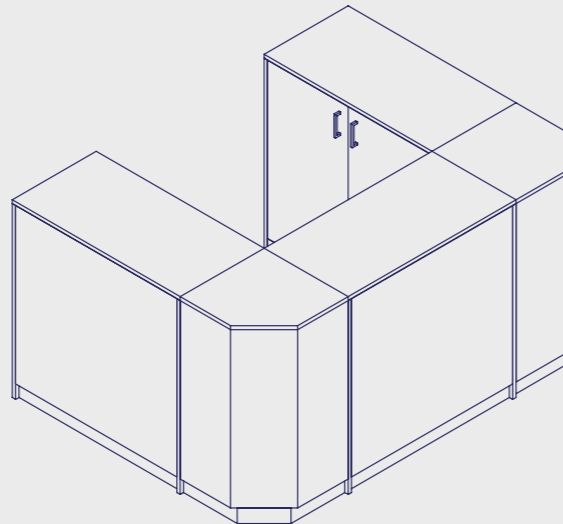
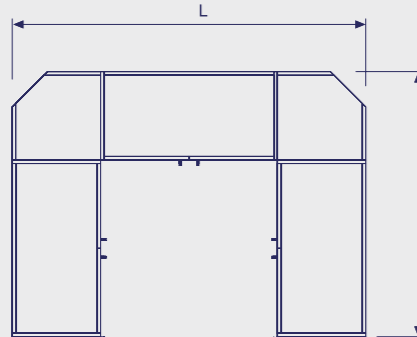
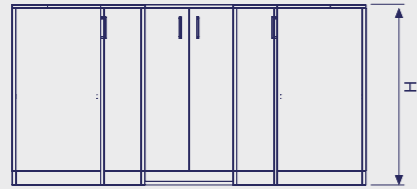

Code / Kod	P	H	L	Description / Açıklama
15U0000002U	1500	1000	2000	

RAS WOODEN TABLE FOR SCALES
RAS TERAZİ BANKOSU

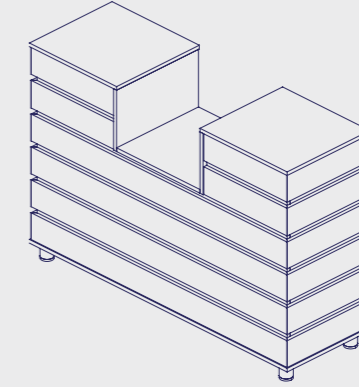
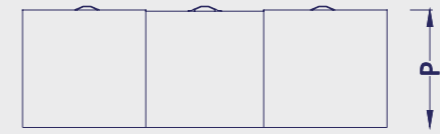
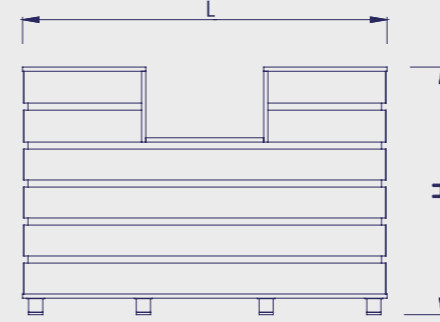

Code / Kod	P	H	L	Description / Açıklama
15T0000002U	500	750	1500	



**FRUIT &
VEGETABLE
UNIT**
MEYVE VE
SEBZE REYONU

RASTABAN WOODEN TABLE FOR SCALES
RASTABAN TERAZİ BANKOSU

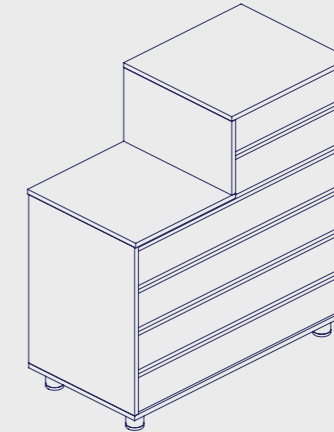
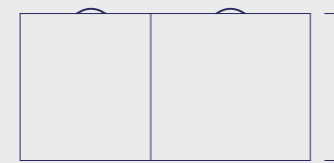
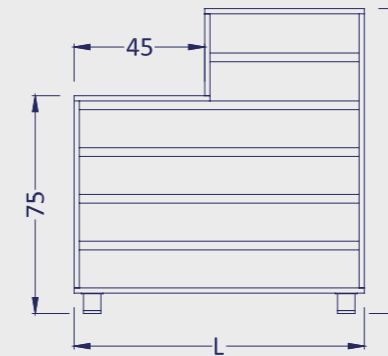

Code / Kod	P	H	L	Description / Açıklama
15T0000001U	500	1050	1000	



**ELECTRONIC &
MUSIC & BOOK**

ELEKTRONİK &
MÜZİK & KİTAP



**ELECTRONIC &
MUSIC & BOOK**
ELEKTRONİK &
MÜZİK & KİTAP

LCD STAND
LCD ÜNİTESİ

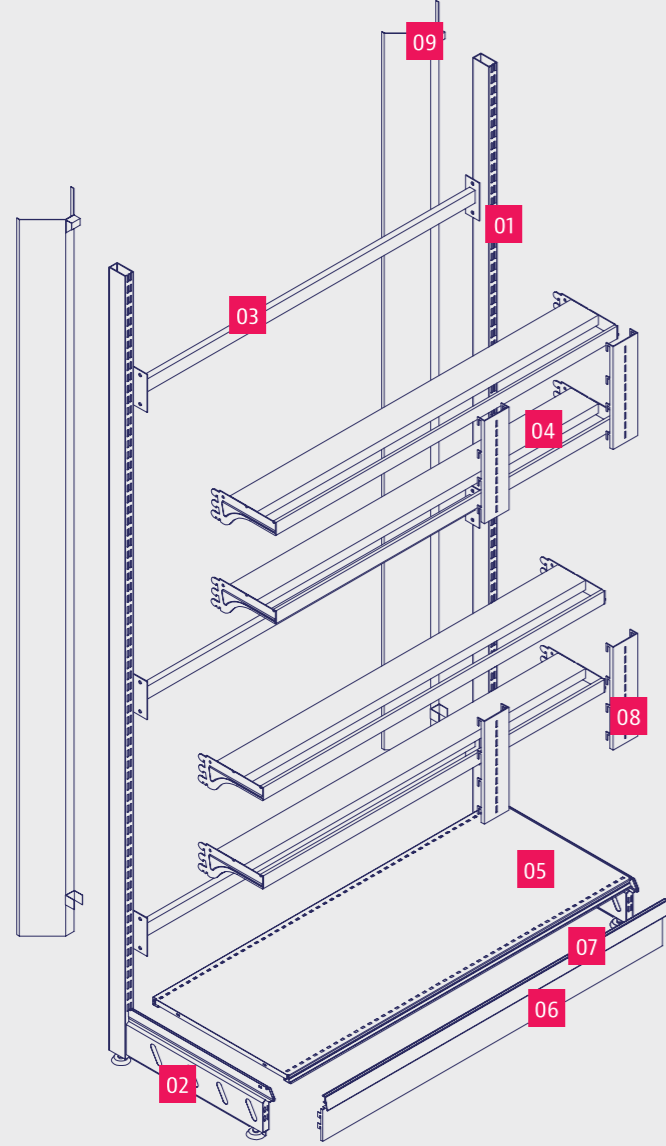

01
Upright 30x80 Box Profile
30x80 Kutu Profil

02
Base Leg
Geçme Ayak

03
Fixing Beam
Ara Bağlantı Profili

04
LCD Holder Bar
LCD Tutucu Bar

05
Shelf
Blok Raf

06
Front Panel
Alt Ön Panel

07
Label Holder
Raf Etiketliği

08
LCD Holder
LCD Tutucu

09
Channel For Led light
Led Aydınlatma Kanalı

LCD HOLDER BAR
LCD TUTUCU BAR

Code / Kod	P	H	L	Description / Açıklama
17C0000001B	200		700	
17C0000002B	200		900	
17C0000003B	200		1000	
17C0000004B	200		1250	
17C0000005B	200		1330	

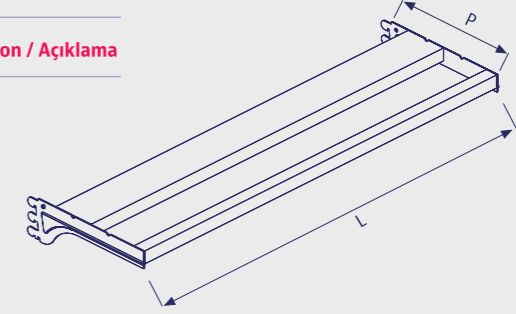

**ELECTRONIC &
MUSIC & BOOK**
ELEKTRONİK &
MÜZİK & KİTAP

LCD HOLDER
LCD TUTUCU

Code / Kod	P	H	L	Description / Açıklama
16C0000001B		500		

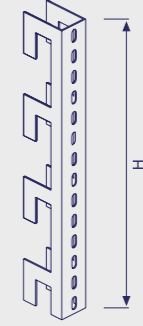

CABLE HOLDER WITH 2 PLUG HOLES
KABLO KANALI 2 PRİZ DELİKLİ

Code / Kod	P	H	L	Description / Açıklama
16C0000006U		100	500	
16C0000007U		100	700	

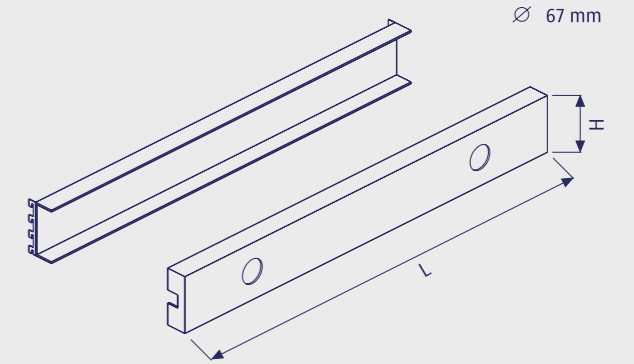

CABLE HOLDER WITH 4 PLUG HOLES
KABLO KANALI 4 PRİZ DELİKLİ

Code / Kod	P	H	L	Description / Açıklama
16C0000012U		100	900	
16C0000002U		100	1000	
16C0000013U		100	1250	
16C0000014U		100	1330	

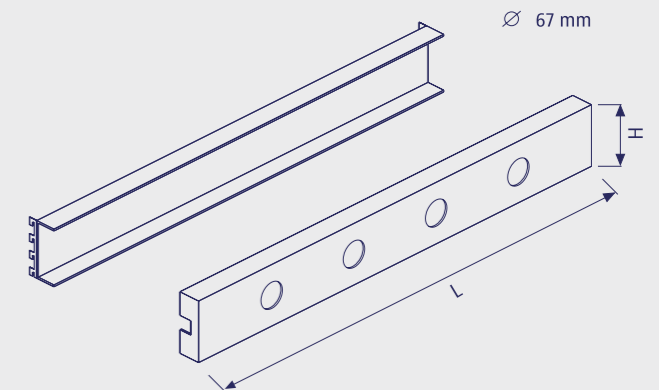



**ELECTRONIC &
MUSIC & BOOK**
ELEKTRONİK &
MÜZİK & KİTAP

REAR BAR ASKI TUTUCU

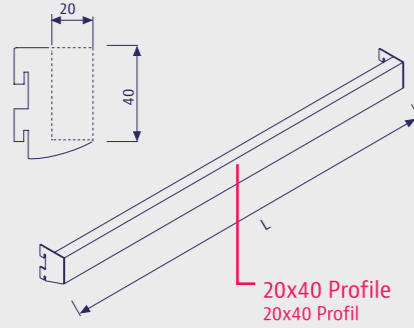

Code / Kod	P	H	L	Description / Açıklama
11I0000001N		500		Chrome coated
11I0000003N		700		Nikel kaplama
11I0000005N		900		Zinc coated
11I0000006N		1000		Çinko kaplama için
11I0000007N		1250		müşteri temsilcisine
11I0000008N		1330		başvurun.

AIRCONDITION HOLDER FOR REAR BAR ASKI TUTUCUYA GEÇME KLİMA TUTUCU

Code / Kod	P	H	L	Description / Açıklama
11D0000026B		200		

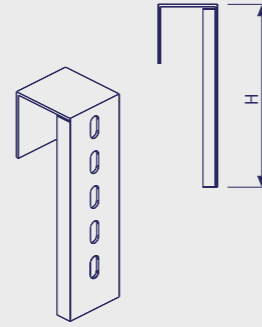

FRONT PANEL WITH PLEXY FRAME PLEKSİ ÇERÇEVELİ ALT ÖN PANEL

Code / Kod	P	H	L	Description / Açıklama
10A0000037U		100	500	Together with plexy
10A0000039U		100	700	Pleksİ ile beraber
10A0000041U		100	900	Led light to be calculated
10A0000042U		100	1000	seperately.
10A0000044U		100	1250	Led ışık ayrıca
10A0000045U		100	1330	hesaplanacaktır.

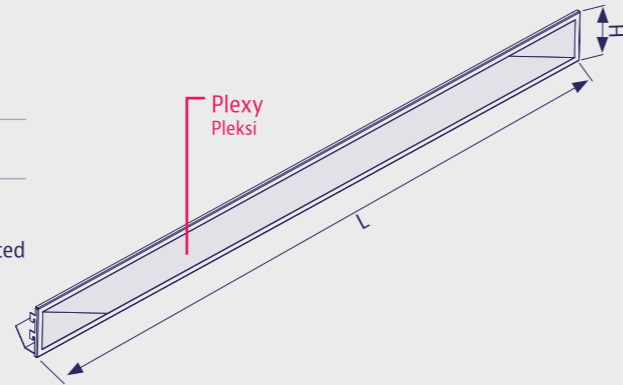

TOP COVER FOR GONDOLA WITH PLEXY CHANNEL ORTA REYON KAPAĞI PLEKSİ KANALLI

Code / Kod	P	H	L	Description / Açıklama
10B0000130U	60	500		*For 30x60 Upright
10B0000132U	60	700		*30x60 dikme için
10B0000134U	60	900		
10B0000135U	60	1000		
10B0000137U	60	1250		
10B0000138U	60	1330		
10B0000139U	80	500		*For 30x80 Upright
10B0000141U	80	700		*30x80 dikme için
10B0000143U	80	900		
10B0000144U	80	1000		
10B0000146U	80	1250		
10B0000147U	80	1330		

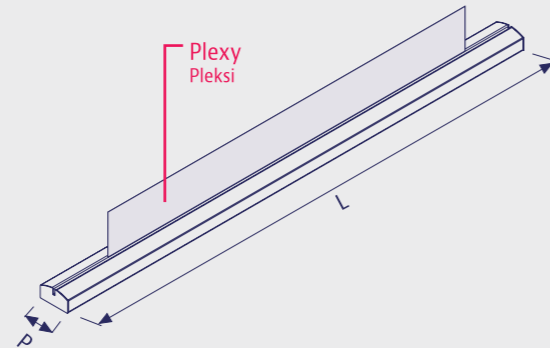

CHANNEL FOR LED LIGHT LED AYDINLATMA KANALI

Code / Kod	P	H	L	Description / Açıklama
16C0000015B		1430		
16C0000016B		1640		
16C0000017B		1850		
16C0000018B		2060		
16C0000004B		2480		
16C0000005B		2690		

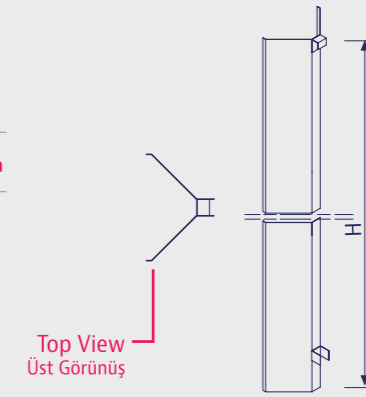

**ELECTRONIC &
MUSIC & BOOK**
ELEKTRONİK &
MÜZİK & KİTAP

HOSE HOLDER FOR REAR BAR ASKI TUTUCUYA GEÇME HORTUM TUTUCU

Code / Kod	P	H	L	Description / Açıklama
11E0000013B	121	190	320	Chrome coated / Nikel kaplama Painted / Boyalı

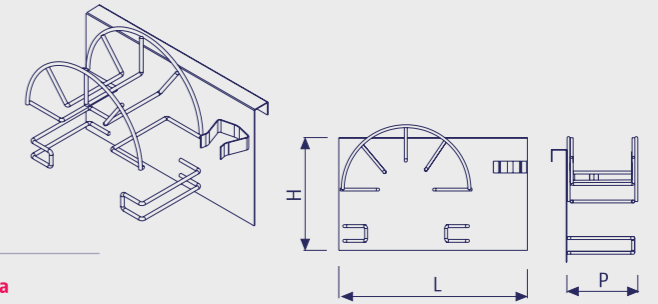

VACUUM CLEANER HOLDER FOR REAR BAR ASKI TUTUCUYA GEÇME ELEKTRİK SÜPÜRGESİ TUTUCU

Code / Kod	P	H	L	Description / Açıklama
11E0000012B	420	400	300	Will be used with 2 rear bar 2 askı tutucu ile kullanılır.

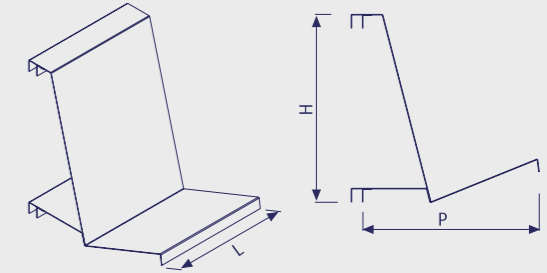

HAIR DRYER HOLDER FOR REAR BAR ASKI TUTUCUYA GEÇME FÖN MAKİNASI TUTUCU

Code / Kod	P	H	L	Description / Açıklama
11E0000010B	160	115		Chrome coated / Nikel kaplama Zinc coated / Çinko kaplama

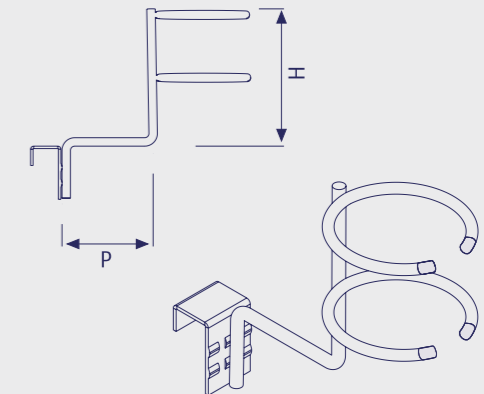



**ELECTRONIC &
MUSIC & BOOK**
ELEKTRONİK &
MÜZİK & KİTAP

HAIR CURLER HOLDER FOR REAR BAR
ASKI TUTUCUYA GEÇME SAC ŞEKİLLENDİRİCİ TUTUCU

Code / Kod	P	H	L	Description / Açıklama
11E0000011B	390			Chrome coated / Nikel kaplama Zinc coated / Çinko kaplama

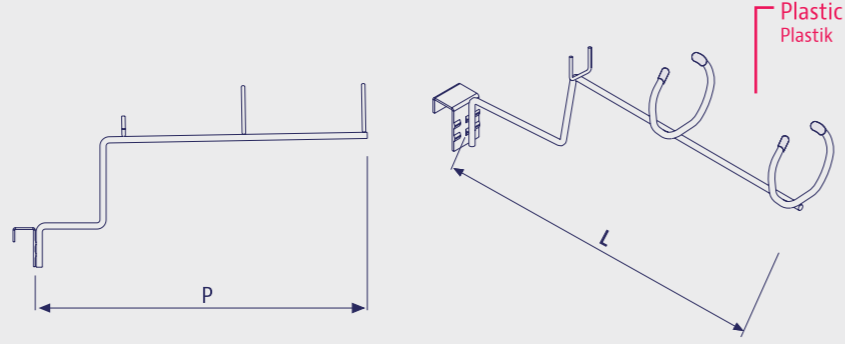

MAYA WOODEN GLASS COUNTER
MAYA AHSAP CAM BANKO

Code / Kod	P	H	L	Description / Açıklama
16B0000018U	550	1000	1200	

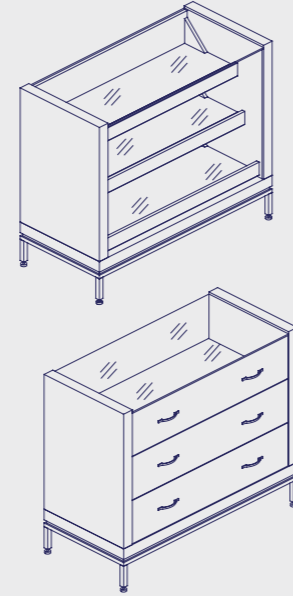
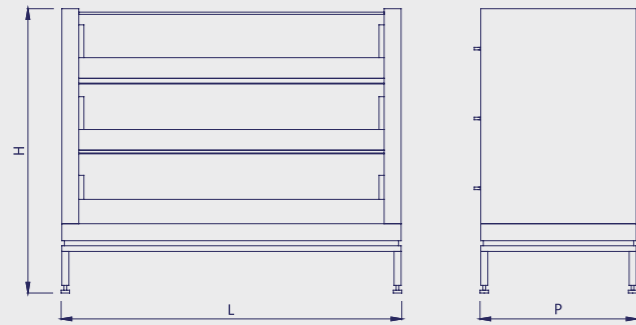

**MONO WOODEN
GLASS COUNTER**
MONO AHSAP
CAM BANKO

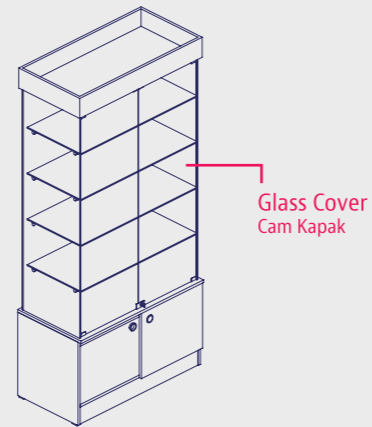
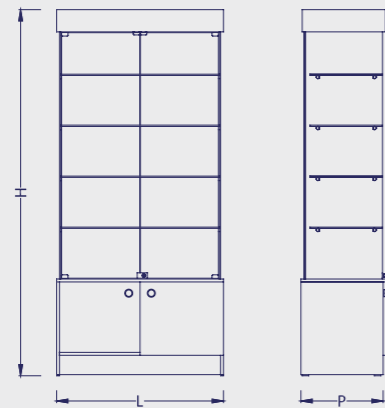

Code / Kod	P	H	L	Description / Açıklama
16B0000019U	550	1000	1200	

VOLGA WOODEN GLASS COUNTER
VOLGA AHSAP BANKO

Code / Kod	P	H	L	Description / Açıklama
16B0000005U	600	1000	1200	

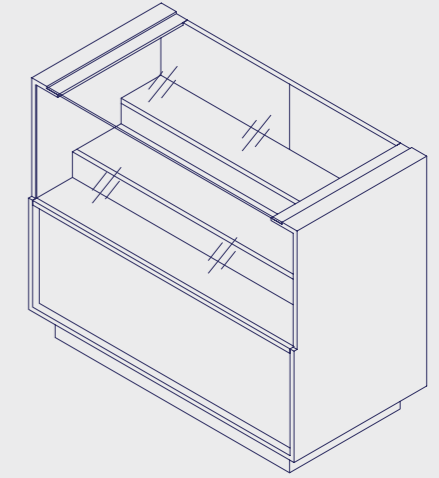
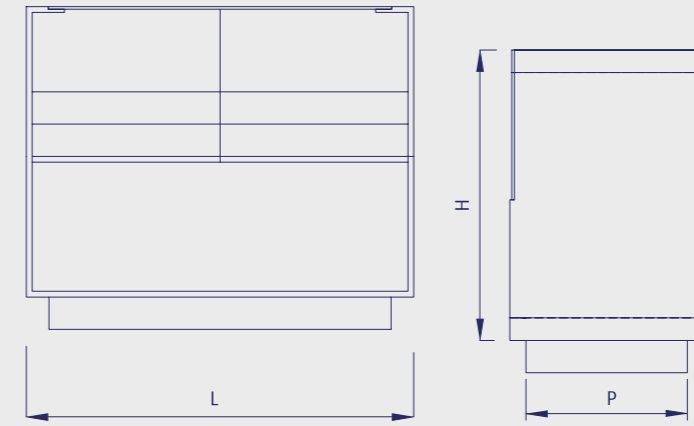

TUNA METAL COUNTER WITH GLASS SLIDING DOORS
TUNA METAL BANKO

Code / Kod	P	H	L	Description / Açıklama
16B0000006U	500	1100	1200	

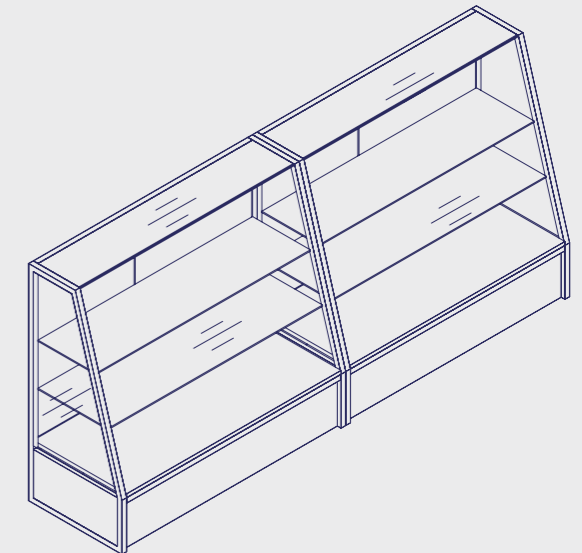
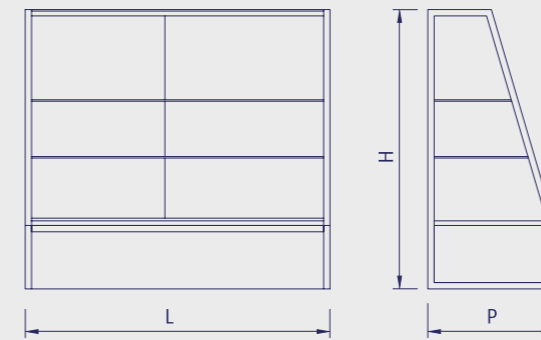

**ELECTRONIC &
MUSIC & BOOK**
ELEKTRONİK &
MÜZİK & KİTAP



**ELECTRONIC &
MUSIC & BOOK**
ELEKTRONİK &
MÜZİK & KİTAP

REN WOODEN GLASS COUNTER - MODULE 1
REN AĖŞAP CAM BANKO - MODÜL 1

Module 1
Modül 1

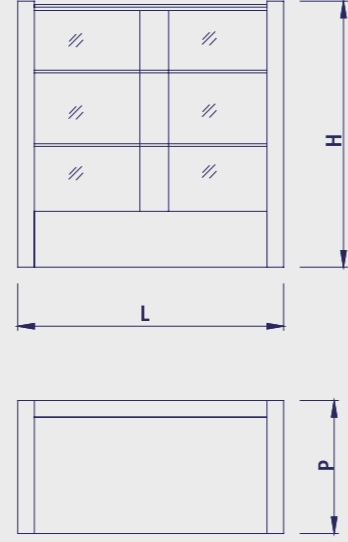
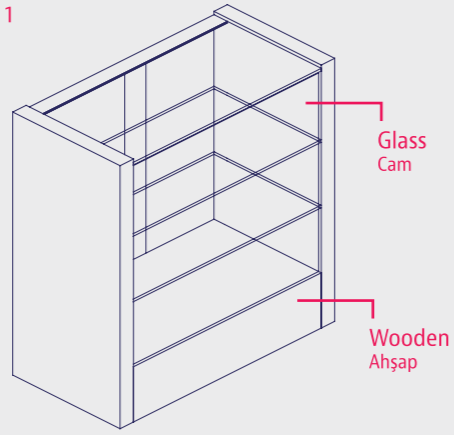

REN WOODEN GLASS COUNTER - MODULE 2
REN AĖŞAP CAM BANKO - MODÜL 2

Module 2
Modül 2

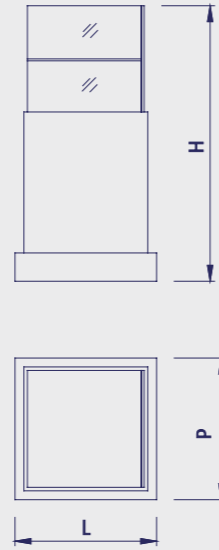
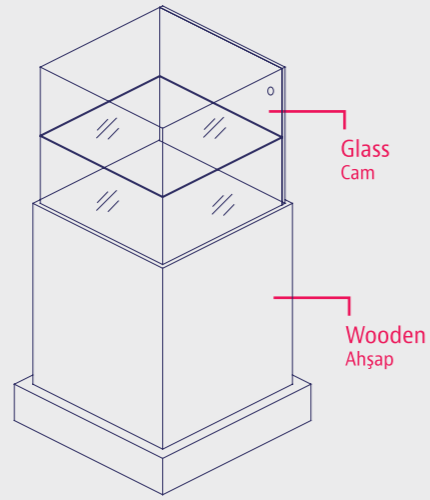

REN WOODEN GLASS COUNTER - MODULE 3
REN AĖŞAP CAM BANKO - MODÜL 3

Module 3
Modül 3

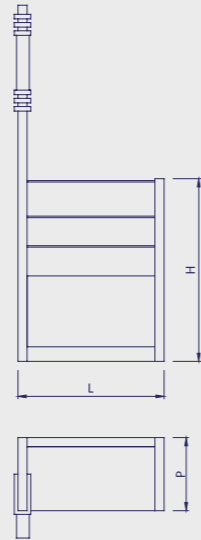
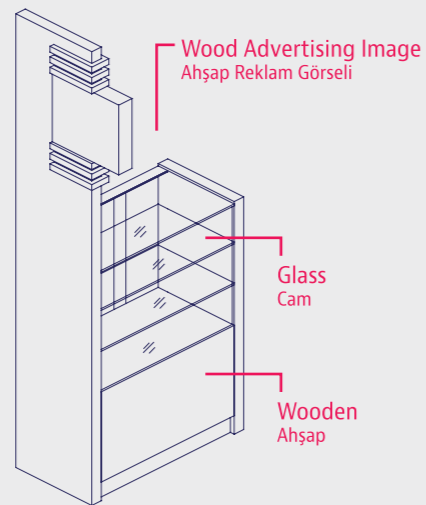

■ Reklam görseli yerin
yüksekliğine göre deęişebilir.
Ad image may vary by height of place.



**ELECTRONIC &
MUSIC & BOOK**
ELEKTRONİK &
MÜZİK & KİTAP

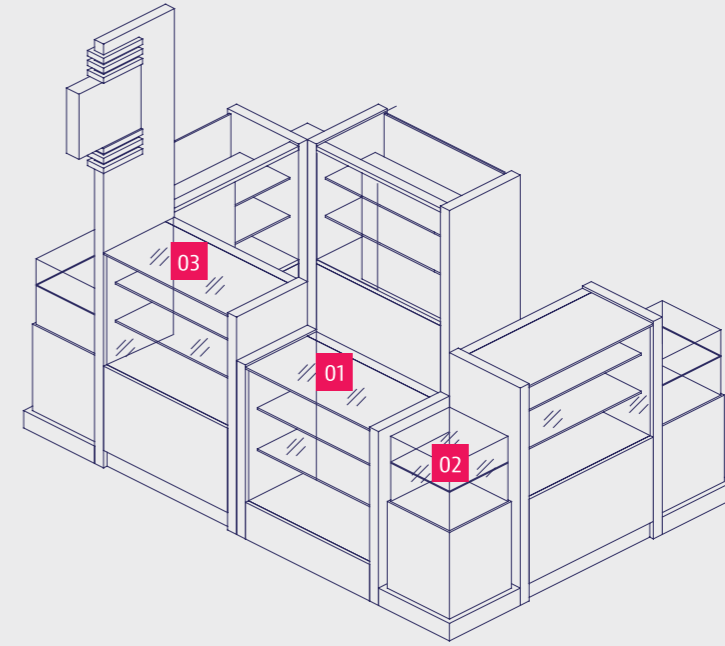
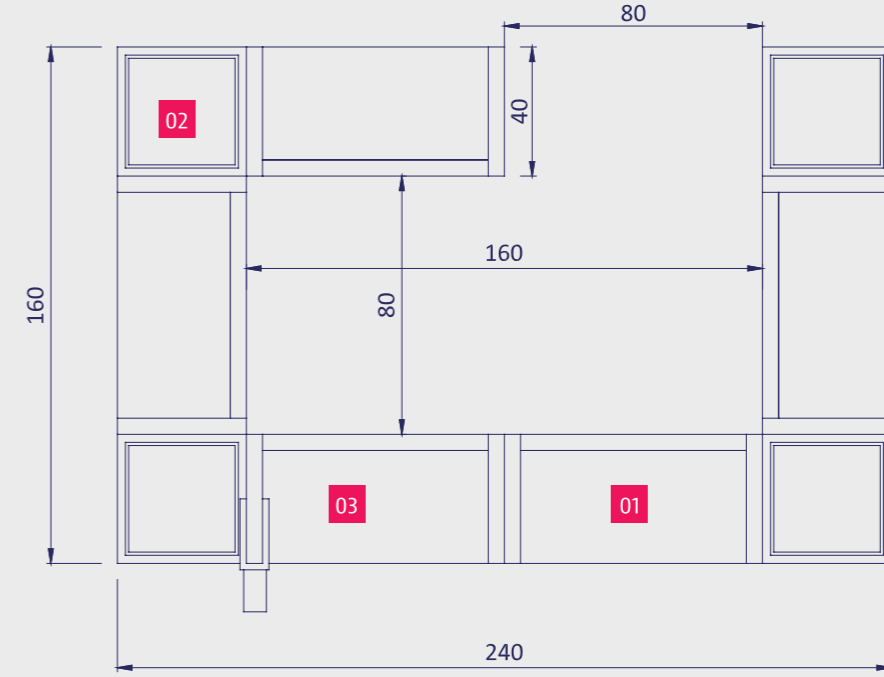

Code / Kod	P	H	L	Description / Açıklama
16B0000007U	400	800	800	Module 1
16B0000008U	400	800	400	Module 2
16B0000009U	400	1000	1345	Module 3



**ELECTRONIC &
MUSIC & BOOK**
ELEKTRONİK &
MÜZİK & KİTAP

SEİN WOODEN GLASS COUNTER - MODULE 1
SEİN AHŞAP CAM BANKO - MODÜL 1

Module 1
Modül 1

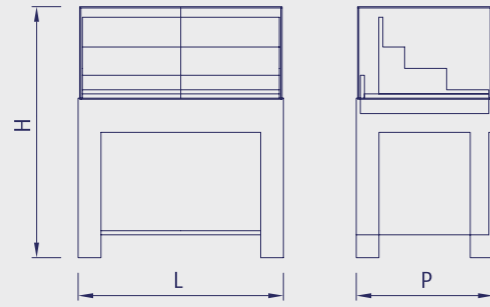

SEİN WOODEN GLASS COUNTER - MODULE 2
SEİN AHŞAP CAM BANKO - MODÜL 2

Module 2
Modül 2

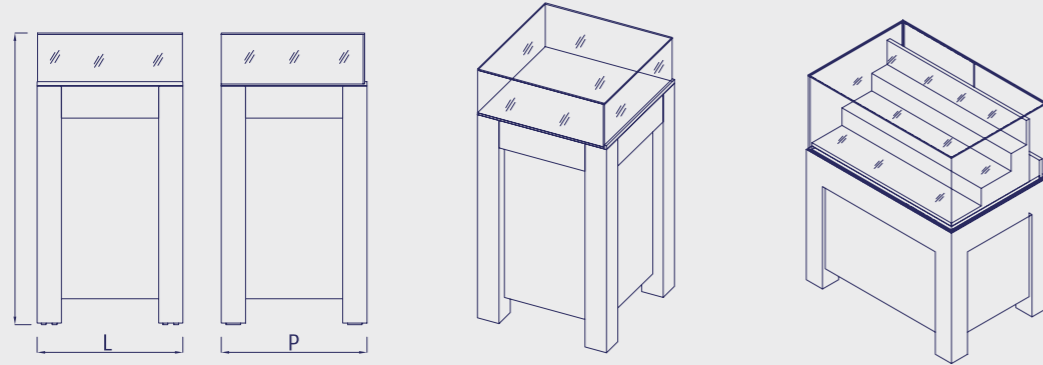

SEİN WOODEN GLASS COUNTER - MODULE 3
SEİN AHŞAP CAM BANKO - MODÜL 3

Module 3
Modül 3

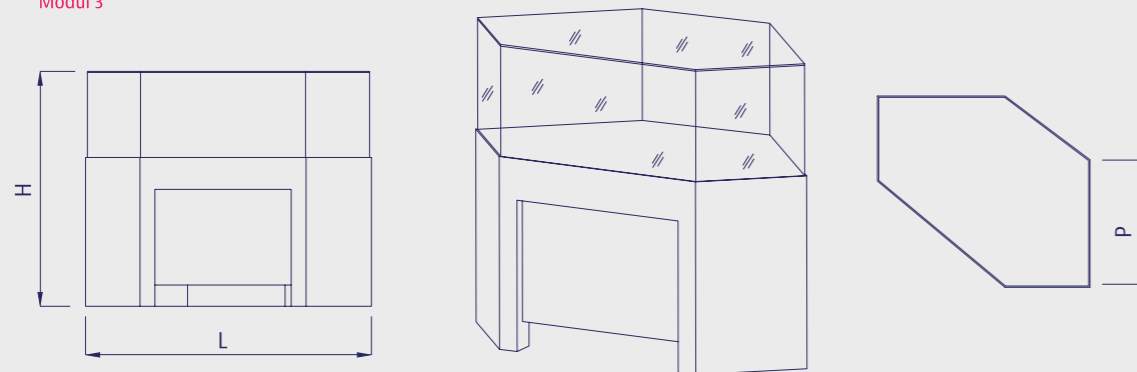

**ELECTRONIC &
MUSIC & BOOK**
ELEKTRONİK &
MÜZİK & KİTAP

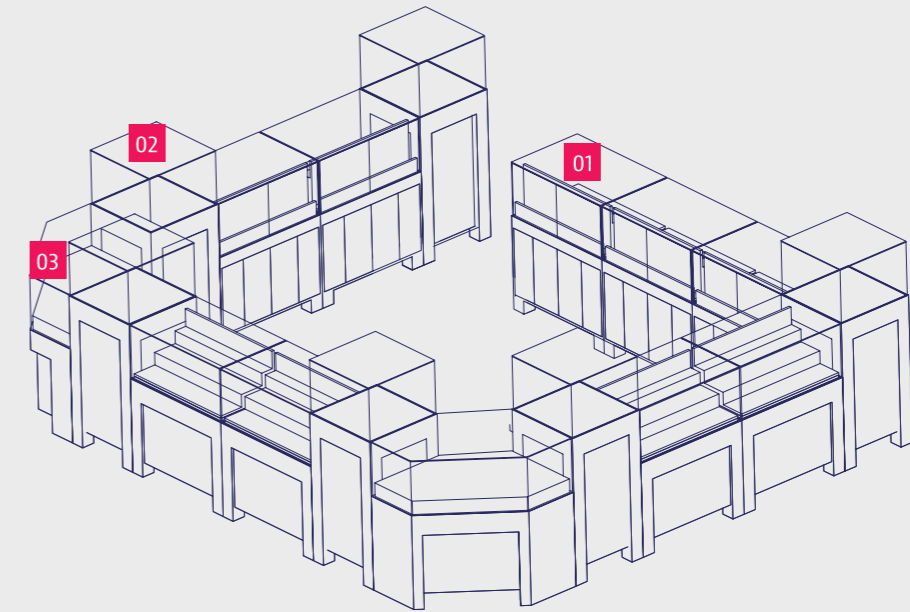
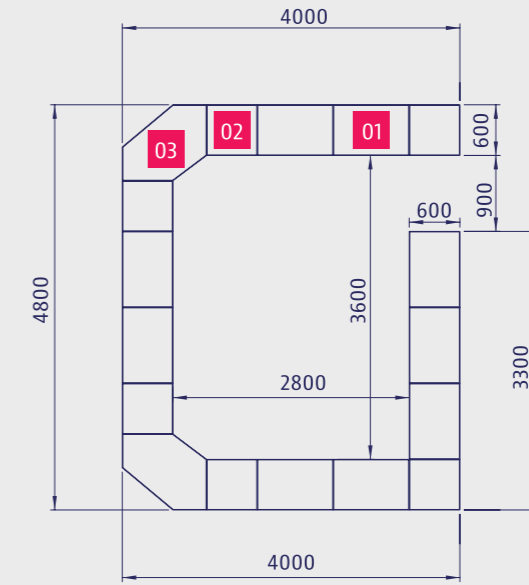

Code / Kod	P	H	L	Description / Açıklama
16B0000010U	600	1100	900	Module 1
16B0000011U	600	1500	600	Module 2
16B0000012U	600	1100	1345	Module 3



**ELECTRONIC &
MUSIC & BOOK**
ELEKTRONİK &
MÜZİK & KİTAP

NİL WOODEN COUNTER FOR ELECTRONIC
NİL AHŞAP ELEKTRONİK BANKOSU

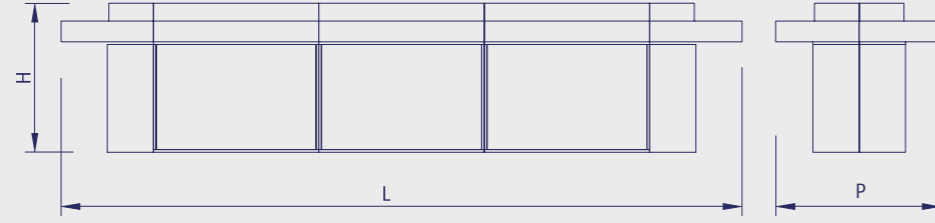

Code / Kod	P	H	L	Description / Açıklama
16B0000013U	1000	1100	4570	Length may change depending on project. Uzunluk ölçüsü projeye göre değişebilir.

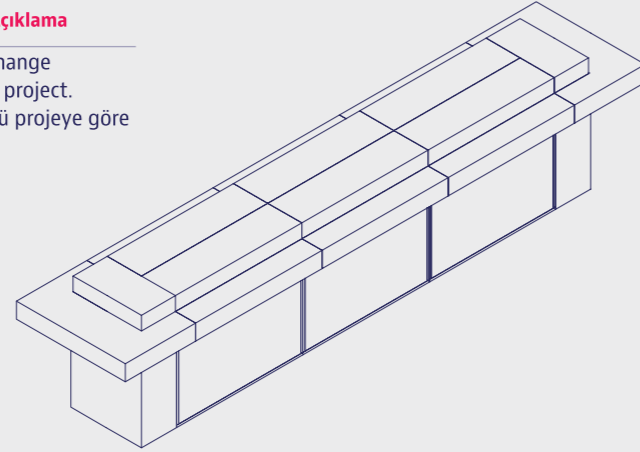

LENA WOODEN COUNTER FOR NOTEBOOK
LENA AHŞAP NOTEBOOK BANKOSU

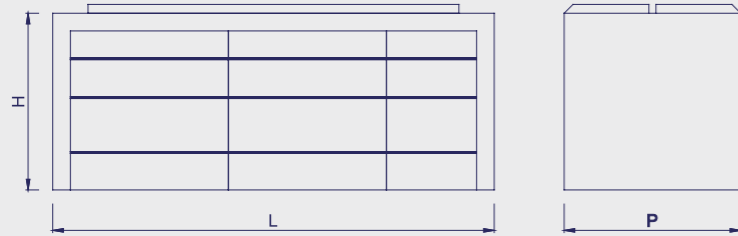

Code / Kod	P	H	L	Description / Açıklama
16B0000014U	1000	1100	2200	Length may change depending on project. Uzunluk ölçüsü projeye göre değişebilir.

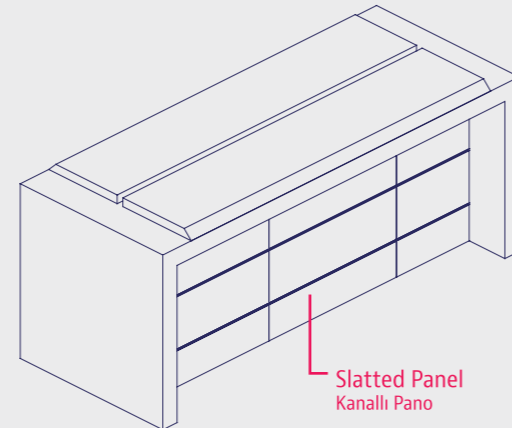

FIRAT WOODEN COUNTER FOR CAMERA & MOBILE PHONE
FIRAT AHŞAP KAMERA VE CEP TELEFONU BANKOSU

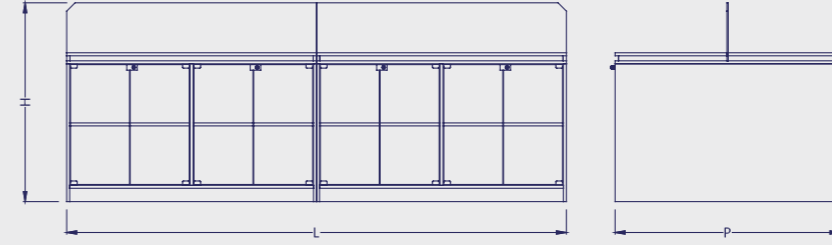

Code / Kod	P	H	L	Description / Açıklama
16B0000016U	1350	1200		Length may change depending on project. Uzunluk ölçüsü projeye göre değişebilir.

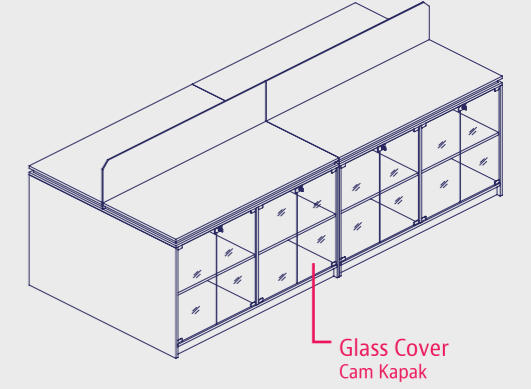

ARAS WOODEN COUNTER FOR CAMERA & MOBILE PHONE
ARAS AHŞAP BANKO

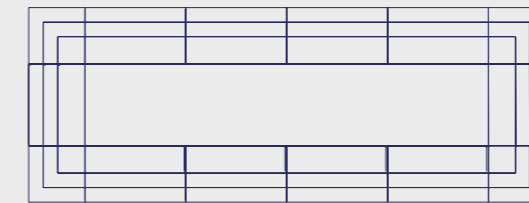
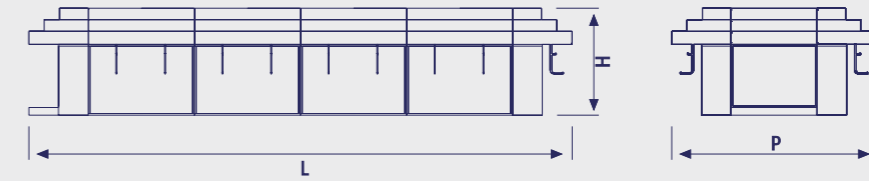

Code / Kod	P	H	L	Description / Açıklama
16B0000017U	2140	1100		Length may change depending on project. Uzunluk ölçüsü projeye göre değişebilir.

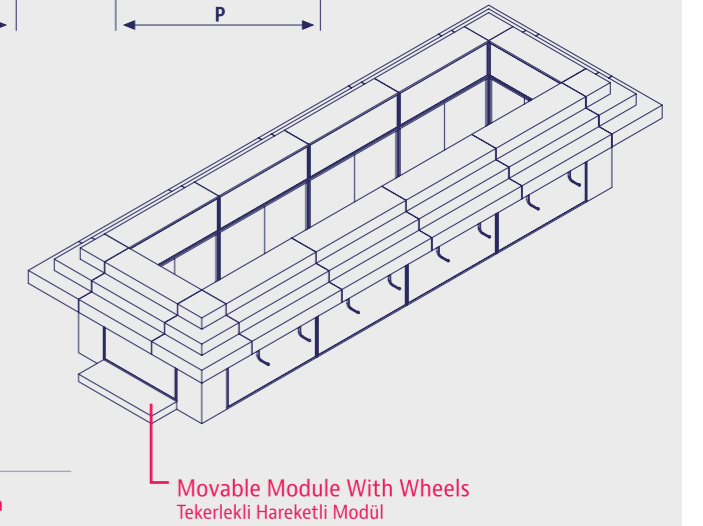

**ELECTRONIC &
MUSIC & BOOK**
ELEKTRONİK &
MÜZİK & KİTAP



**ELECTRONIC &
MUSIC & BOOK**
ELEKTRONİK &
MÜZİK & KİTAP

MAGMA ALUMINUM COUNTER WITH WOODEN CUPBOARD
MAGMA ALÜMİNYUM BANKO ALTI AHAŞAP DOLAPLI

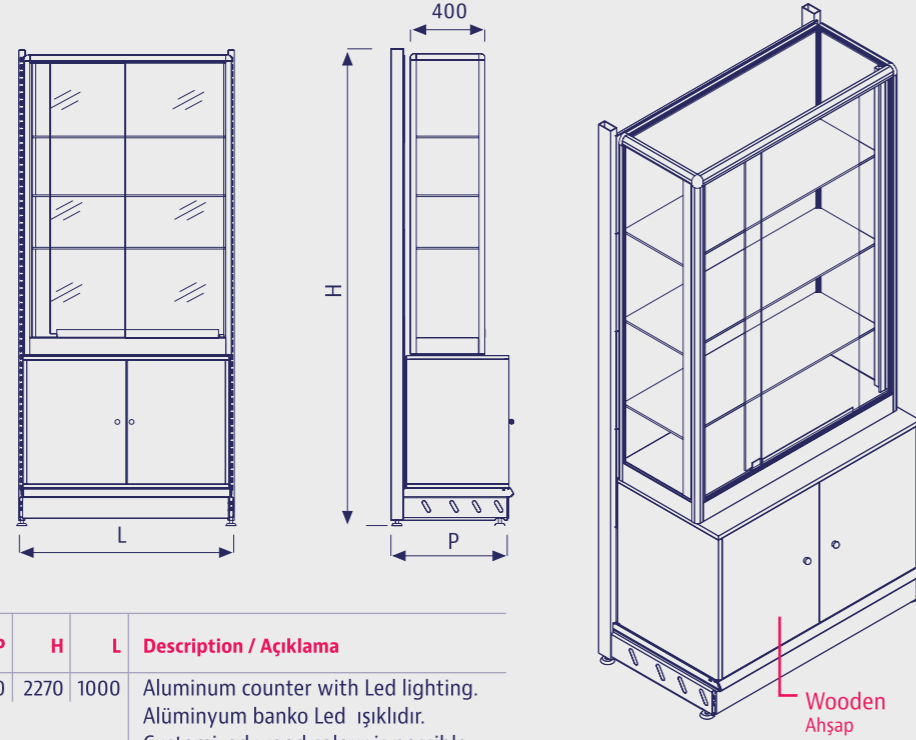

Code / Kod	P	H	L	Description / Açıklama
16B0000015U	560	2270	1000	Aluminum counter with Led lighting. Alüminyum banko Led ışıklıdır. Customized wood colour is possible. Ahşap renkleri müşteri isteğine bağlıdır.

MODUS ALUMINUM GLASS COUNTER
MODUS ALÜMİNYUM CAM BANKO



Code / Kod	P	H	L	Description / Açıklama
16B0000001U	500	2000	1000	Aluminum counter with Led lighting. Alüminyum banko Led ışıklıdır.



**ELECTRONIC &
MUSIC & BOOK**
ELEKTRONİK &
MÜZİK & KİTAP

SHELF FOR CD
CD RAFI

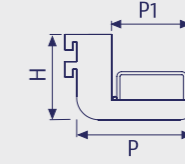

Code / Kod	P	P1	H	L	Description / Açıklama
17E0000019B	150	101	110	500	
17E0000020B	150	101	110	700	
17E0000021B	150	101	110	900	
17E0000022B	150	101	110	1000	
17E0000023B	150	101	110	1250	
17E0000024B	150	101	110	1330	

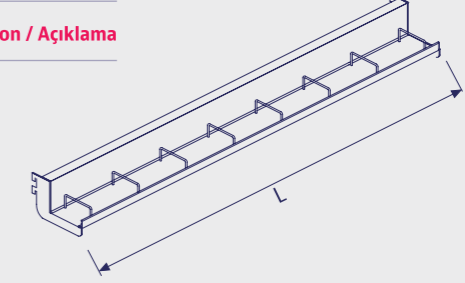

SHELF FOR CD (4 STEPS)
CD RAFI (4 BASAMAKLI)

Code / Kod	P	H	L	Description / Açıklama
17E0000025B	470	190	500	
17E0000026B	470	190	700	
17E0000027B	470	190	900	
17E0000028B	470	190	1000	
17E0000029B	470	190	1250	
17E0000030B	470	190	1330	

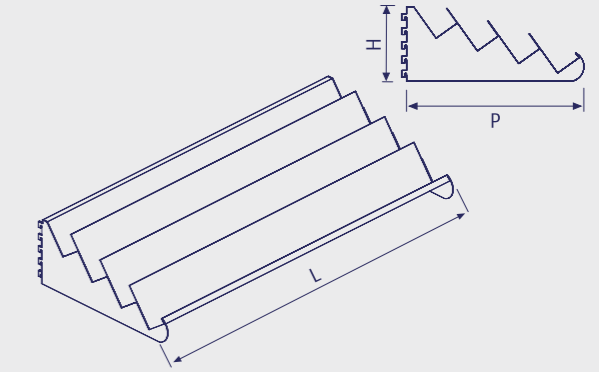

SHELF FOR CD (5 STEPS)
CD RAFI (5 BASAMAKLI)

Code / Kod	P	H	L	Description / Açıklama
17E0000031B	570	260	500	
17E0000032B	570	260	700	
17E0000033B	570	260	900	
17E0000034B	570	260	1000	
17E0000035B	570	260	1250	
17E0000036B	570	260	1330	

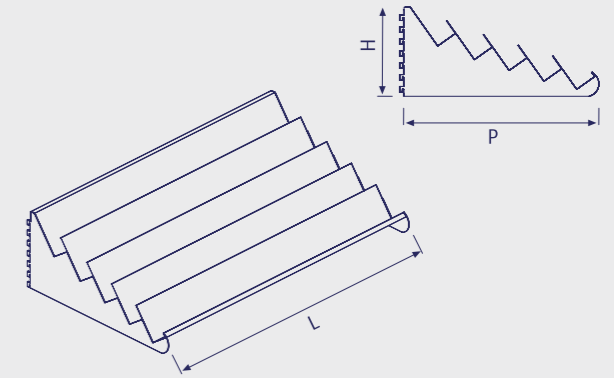

ZIGZAG BOOK SHELF
ZİGZAG KİTAP RAF

Code / Kod	P	H	L	Description / Açıklama
17B0000006U	200	155	500	
17B0000001U	200	155	700	
17B0000002U	200	155	900	
17B0000003U	200	155	1000	
17B0000004U	200	155	1250	
17B0000005U	200	155	1330	

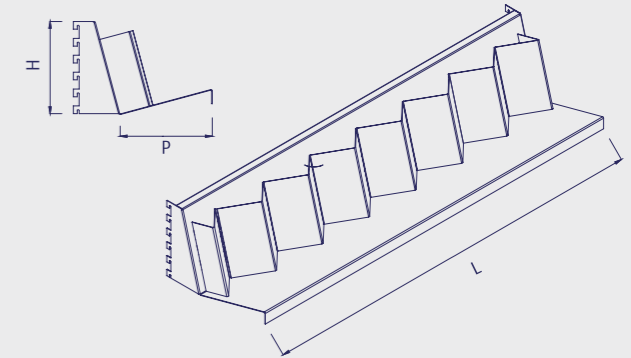



**ELECTRONIC &
MUSIC & BOOK**
ELEKTRONİK &
MÜZİK & KİTAP

SHELF FOR MAGAZINE (5 STEPS)
5'Lİ MAGAZİN RAFI (5 BASAMAKLI)

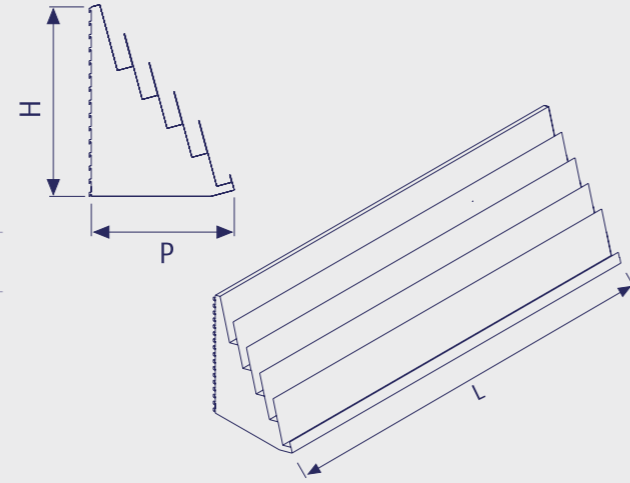

Code / Kod	P	H	L	Description / Açıklama
17A0000025B	530	700	500	
17A0000026B	530	700	700	
17A0000027B	530	700	900	
17A0000028B	530	700	1000	
17A0000029B	530	700	1250	
17A0000030B	530	700	1330	

SHELF FOR CD (2 STEPS)
OVAL CD RAFI (2 BASAMAKLI)

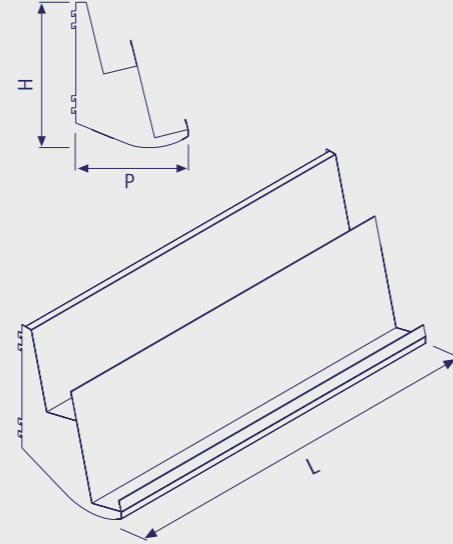

Code / Kod	P	H	L	Description / Açıklama
17E0000007B	325	420	500	
17E0000008B	325	420	700	
17E0000009B	325	420	900	
17E0000010B	325	420	1000	
17E0000011B	325	420	1250	
17E0000012B	325	420	1330	

SHELF FOR CD (1 STEPS)
OVAL CD RAFI (1 BASAMAKLI)

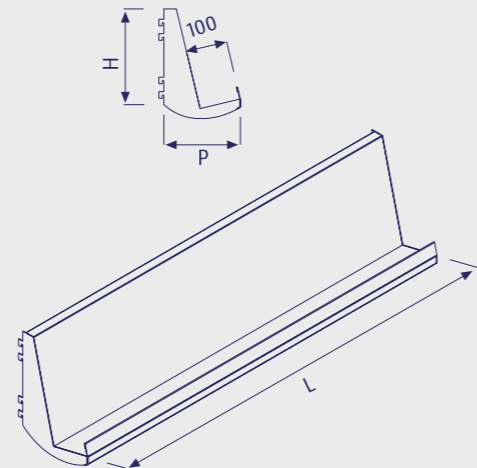

Code / Kod	P	H	L	Description / Açıklama
17E0000001B	185	265	500	
17E0000002B	185	265	700	
17E0000003B	185	265	900	
17E0000004B	185	265	1000	
17E0000005B	185	265	1250	
17E0000006B	185	265	1330	



**ELECTRONIC &
MUSIC & BOOK**
ELEKTRONİK &
MÜZİK & KİTAP

BOOK SHELF WITH ANGLE 78°
AÇILI KİTAP RAFI 78°

Code / Kod	P	H	L	Description / Açıklama
17D0000001B	200	260	700	Separator quantities can be change according to needs.
17D0000002B	200	260	900	
17D0000003B	200	260	1000	Separatör sayısı ihtiyaca göre değişebilir.

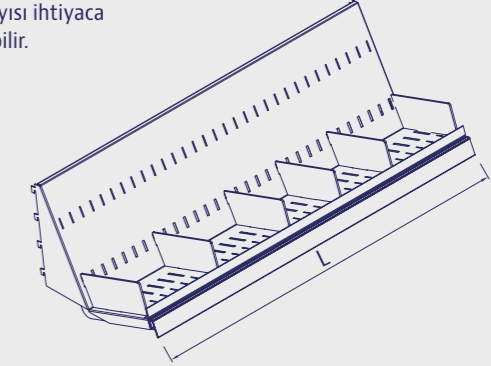
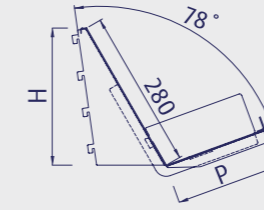

BOOK SHELF WITH ANGLE 70°
AÇILI KİTAP RAFI 70°

Code / Kod	P	H	L	Description / Açıklama
17D0000004B	200	260	700	Separator quantities can be change according to needs.
17D0000005B	200	260	900	
17D0000006B	200	260	1000	Separatör sayısı ihtiyaca göre değişebilir.

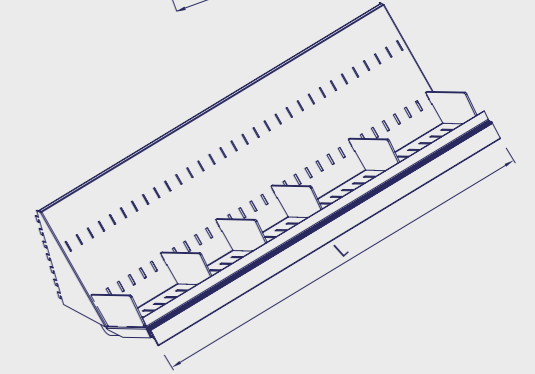
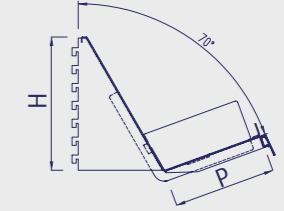

BOOK SHELF WITH ANGLE 100°
AÇILI KİTAP RAFI 100°

Code / Kod	P	H	L	Description / Açıklama
17D0000007B	200	236	700	Separator quantities can be change according to needs.
17D0000008B	200	236	900	
17D0000009B	200	236	1000	Separatör sayısı ihtiyaca göre değişebilir.
17D0000010B	250	236	700	
17D0000011B	250	236	900	
17D0000012B	250	236	1000	

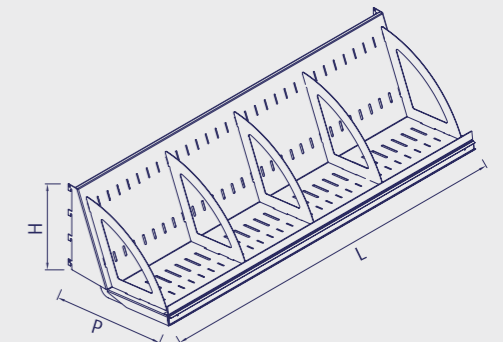
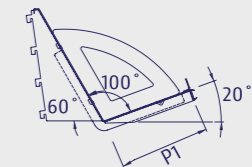



**ELECTRONIC &
MUSIC & BOOK**
ELEKTRONİK &
MÜZİK & KİTAP

ELECTRONIC & MUSIC & BOOK EXAMPLES UNIT
ELEKTRONİK & MÜZİK & KİTAP REYON ÖRNEKLERİ

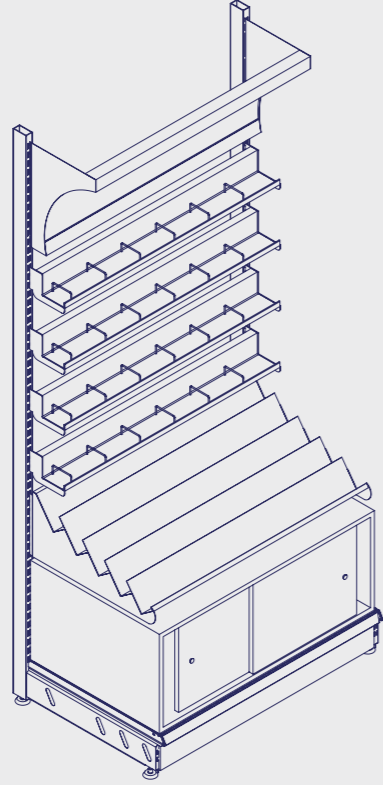

MAGAZINE & BOOK STAND
DERGİ & KİTAP STANDI

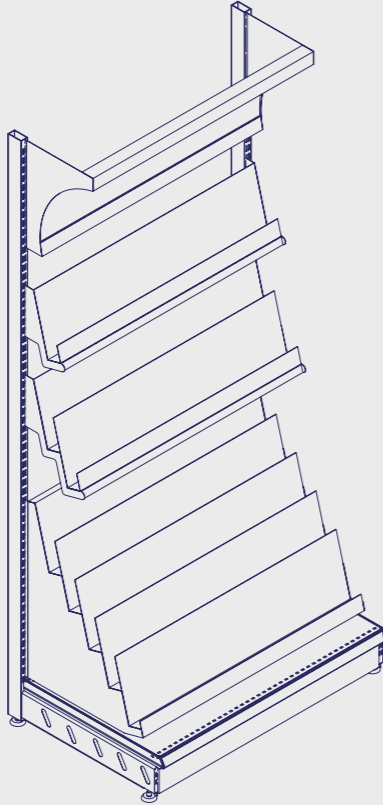

VCD & DVD GONDOLA HEAD STAND
VCD & DVD GONDOLBAŞI STANDI

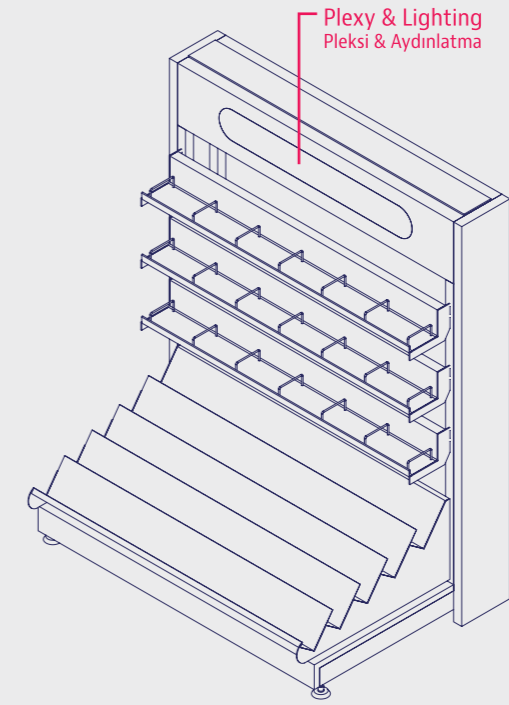

**ELECTRONIC &
MUSIC & BOOK**
ELEKTRONİK &
MÜZİK & KİTAP

VCD & DVD GONDOLA STAND
VCD & DVD ÇİFT YÖNLÜ ORTA STAND

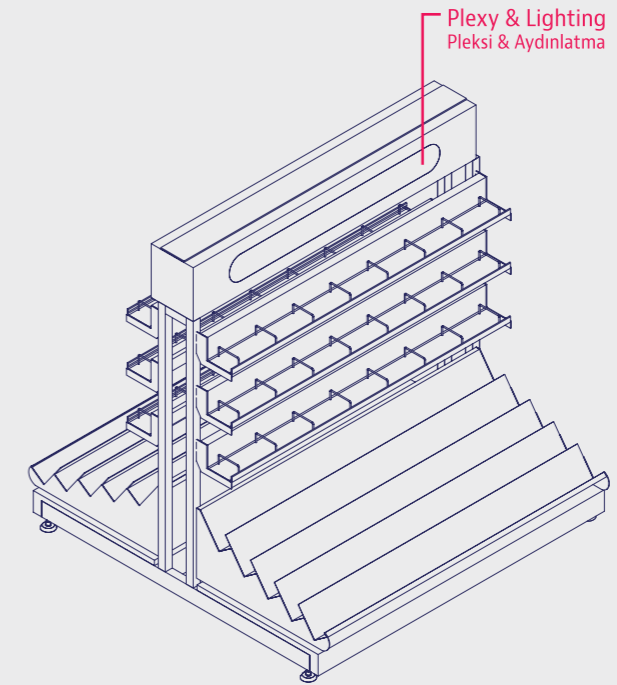



**ELECTRONIC &
MUSIC & BOOK**
ELEKTRONİK &
MÜZİK & KİTAP

VCD & DVD GONDOLA HEAD STAND
VCD & DVD GONDOLBAŞI STANDI

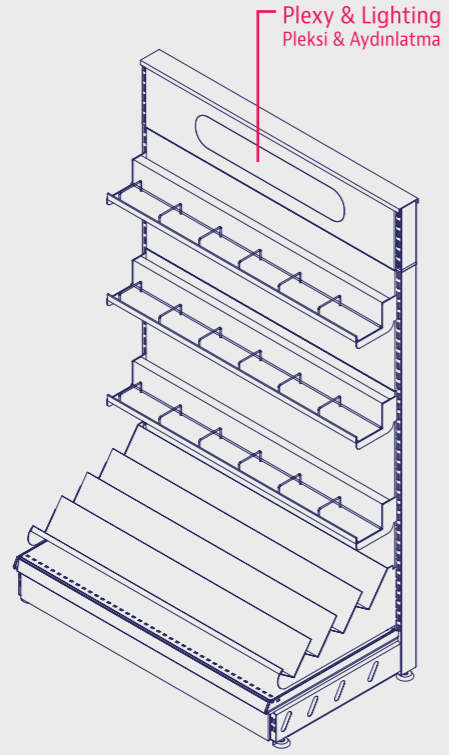

VCD & DVD GONDOLA STAND
VCD & DVD ÇİFT YÖNLÜ ORTA STANDI

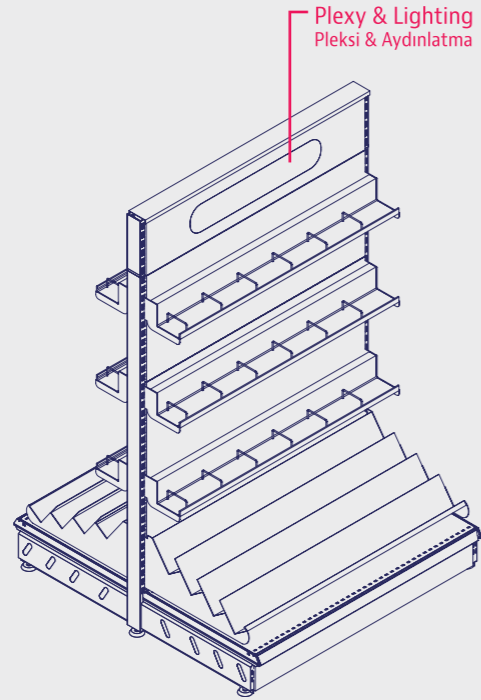

MAGAZINE & BOOK STAND
DERGİ & KİTAP STANDI

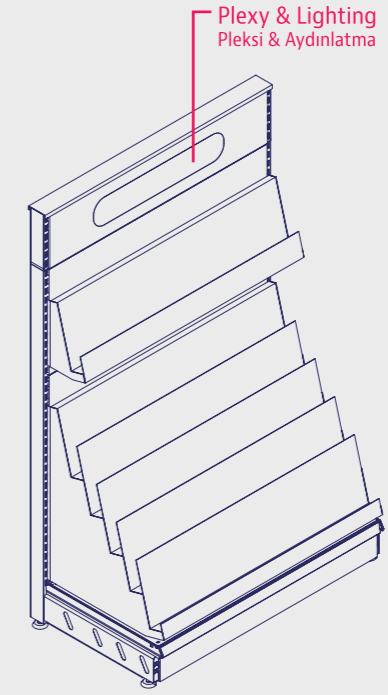

VCD & DVD STAND
VCD & DVD STANDI

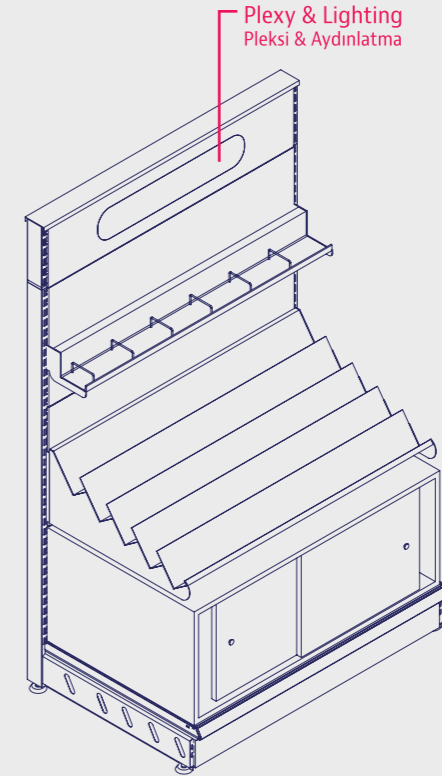

**ELECTRONIC &
MUSIC & BOOK**
ELEKTRONİK &
MÜZİK & KİTAP



**ELECTRONIC &
MUSIC & BOOK**
ELEKTRONİK &
MÜZİK & KİTAP

BOOK STAND
KİTAP STANDI

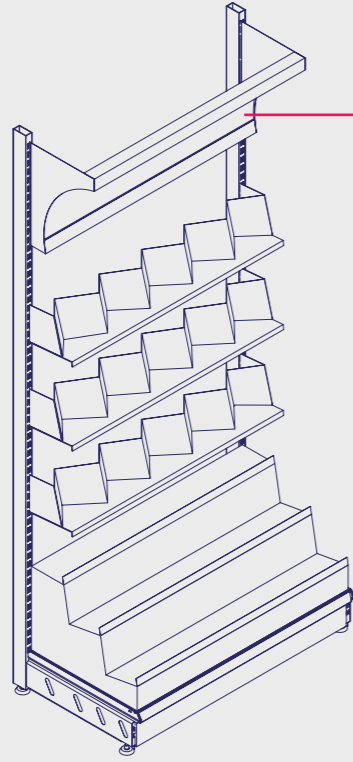

Plexy & Lighting
Pleksi & Aydınlatma

WOODEN STAND FOR BOOKS
AHŞAP KİTAP STANDI

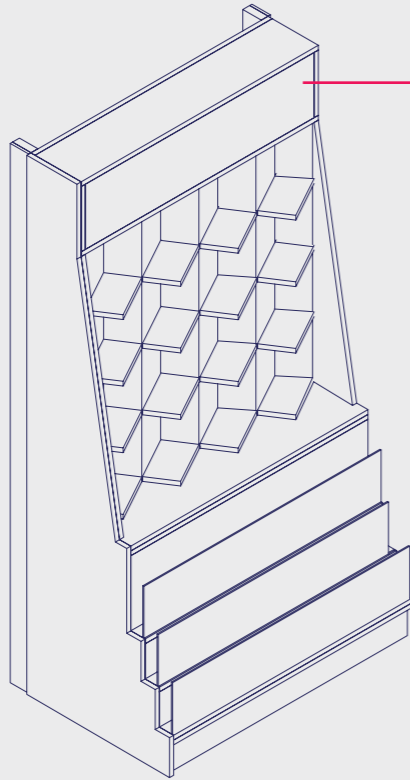

Plexy & Lighting
Pleksi & Aydınlatma



**ELECTRONIC &
MUSIC & BOOK**
ELEKTRONİK &
MÜZİK & KİTAP

WOODEN STAND FOR BOOKS
AHŞAP KİTAP STANDI

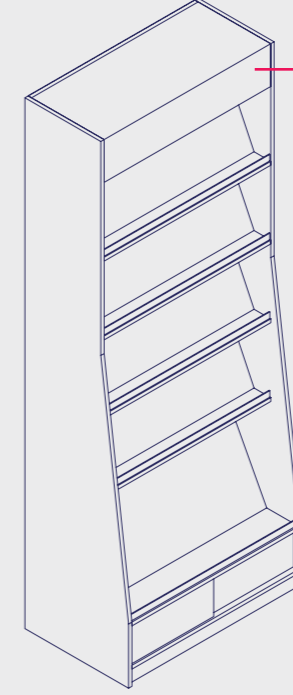

Plexy & Lighting
Pleksi & Aydınlatma

WOODEN STAND FOR BOOKS
AHŞAP KİTAP STANDI

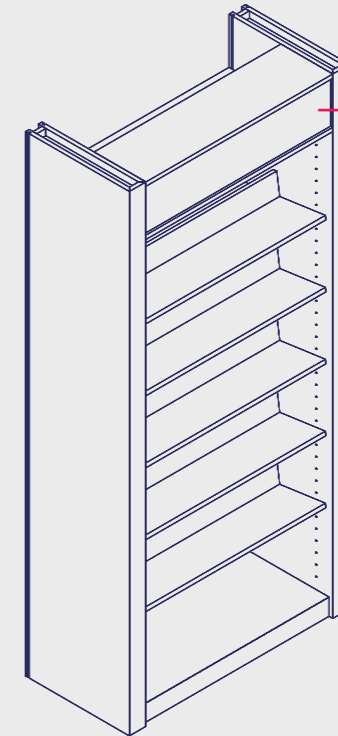

Plexy & Lighting
Pleksi & Aydınlatma



**ELECTRONIC &
MUSIC & BOOK**
ELEKTRONİK &
MÜZİK & KİTAP

STAND FOR BAGS (METAL)
ÇANTA STANDI - METAL

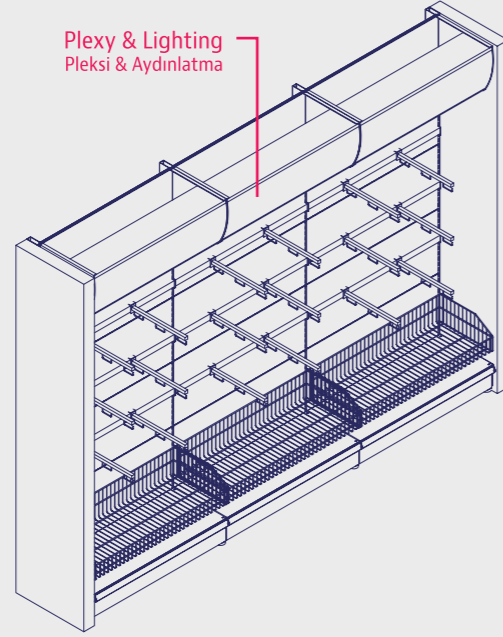

STAND FOR STATIONERY (METAL)
KIRTASIYE STANDI-METAL

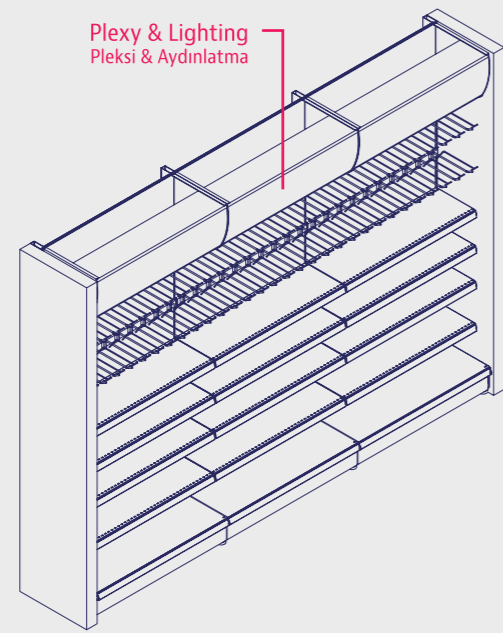

**ELECTRONIC &
MUSIC & BOOK**
ELEKTRONİK &
MÜZİK & KİTAP

STAND FOR NOTEBOOK (METAL)
METAL DEFTER STANDI

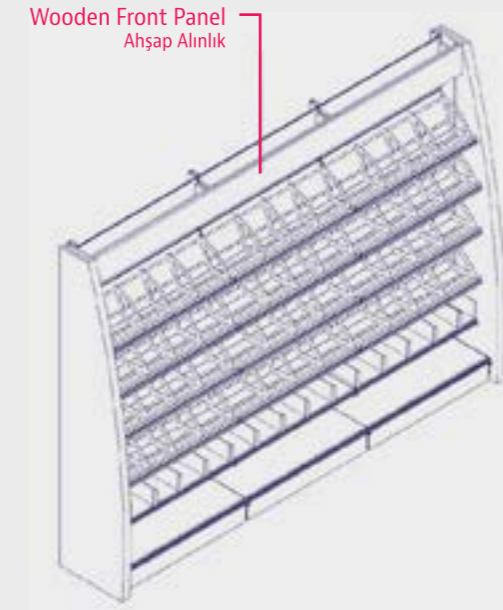

STAND FOR NOTEBOOK (METAL)
METAL DEFTER STANDI

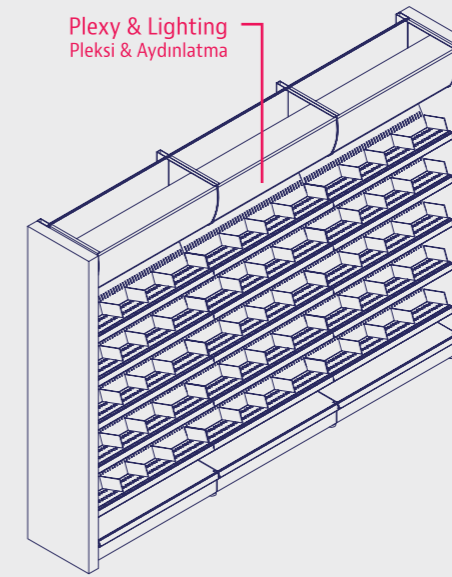



TURNSTILES & BARRIERS

**TURNİKELER &
BARIYERLER**



TURNSTILES & BARRIERS
TURNİKELER & BARİYERLER

UPRIGHT FOR TURNSTILE WITH 2 SOCKETS ONE DIRECTION
TEK TARAFLI TURNİKE DİKMESİ

Code / Kod	P	H	L	Description / Açıklama
12A0000001		1070		Chrome Coated Nikel Kaplama

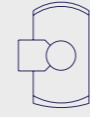
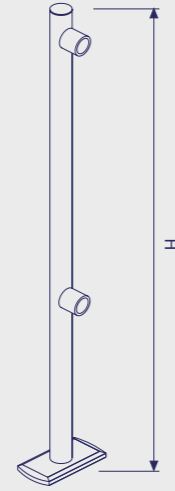

UPRIGHT FOR TURNSTILE WITH 4 SOCKETS DOUBLE DIRECTION 180°
ÇİFT TARAFLI TURNİKE DİKMESİ 180°

Code / Kod	P	H	L	Description / Açıklama
12A0000002		1070		Chrome Coated Nikel Kaplama

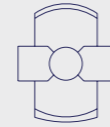
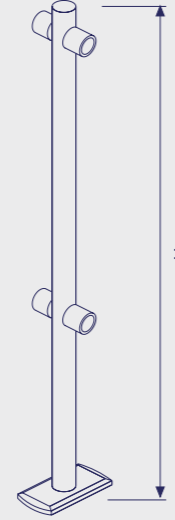

UPRIGHT FOR TURNSTILE WITH 4 SOCKETS DOUBLE DIRECTION 90°
ÇİFT TARAFLI TURNİKE DİKMESİ 90°

Code / Kod	P	H	L	Description / Açıklama
12A0000003		1070		Chrome Coated Nikel Kaplama

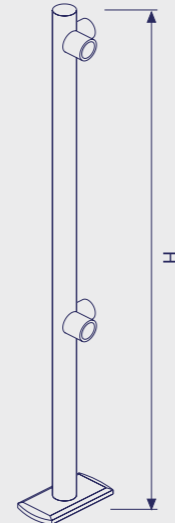

TURNSTILES & BARRIERS
TURNİKELER & BARİYERLER

UPRIGHT FOR TURNSTILE WITH 6 SOCKETS THREE DIRECTION
ÜÇ TARAFLI TURNİKE DİKMESİ

Code / Kod	P	H	L	Description / Açıklama
12A0000004		1070		Chrome Coated Nikel Kaplama

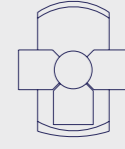
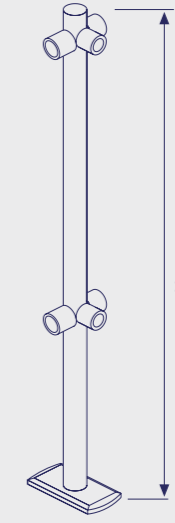

UPRIGHT FOR TURNSTILE WITH 8 SOCKETS FOUR DIRECTION
DÖRT TARAFLI TURNİKE DİKMESİ

Code / Kod	P	H	L	Description / Açıklama
12A0000005		1070		Chrome Coated Nikel Kaplama

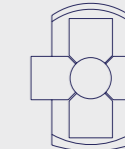
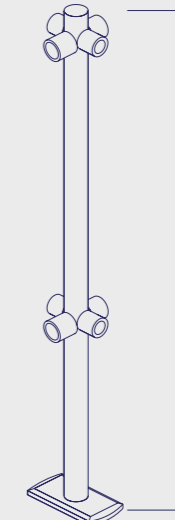

TURNSTILE BARRIER
TURNİKE BORUSU

Code / Kod	P	H	L	Description / Açıklama
12B0000005N			500	Chrome Coated
12B0000004N			750	Nikel Kaplama
12B0000003N			1000	
12B0000001N			1500	
12B0000002N			2000	

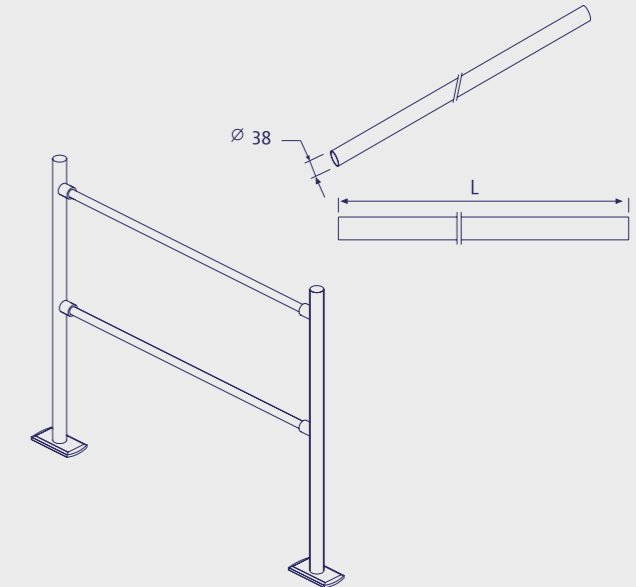



**TURNSTILES &
BARRIERS**
TURNİKELER &
BARİYERLER

LEFT MECHANICAL ACCESS GATE
SOL AÇILIR YAPRAK TURNİKE

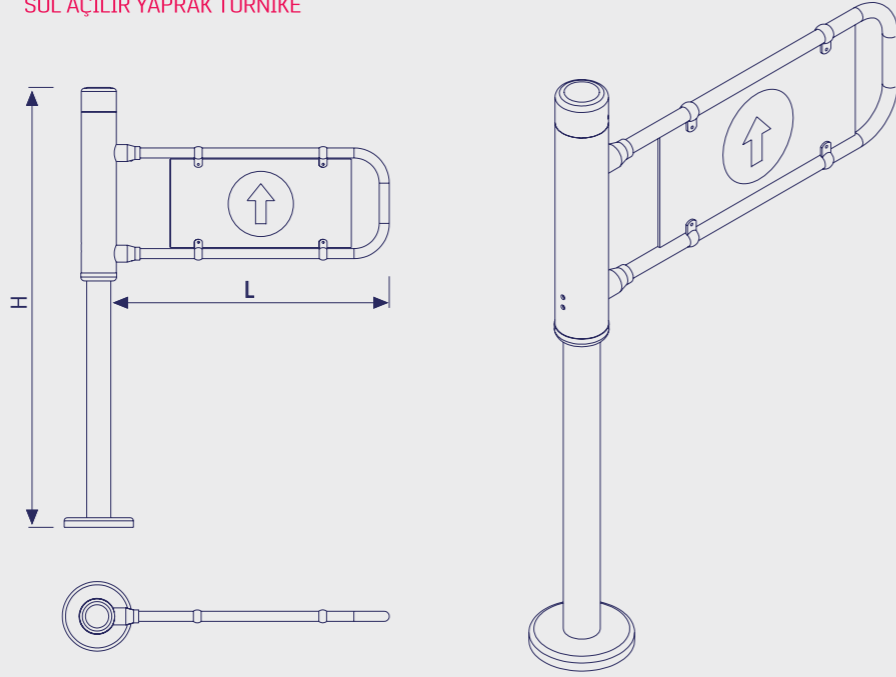

Code / Kod	P	H	L	Description / Açıklama
12D0000002N		1135	650	Chrome Coated Nikel Kaplama

RIGHT MECHANICAL ACCESS GATE
SAĞ AÇILIR YAPRAK TURNİKE

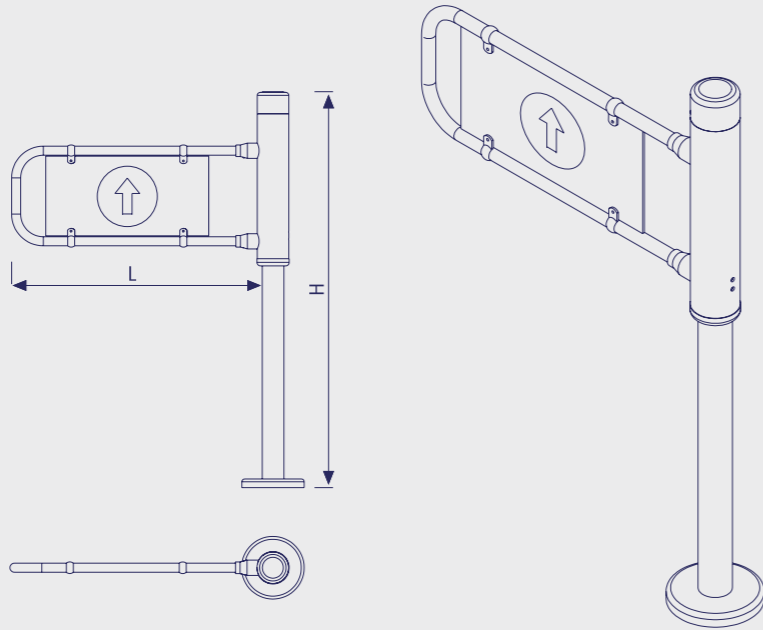

Code / Kod	P	H	L	Description / Açıklama
12D0000001N		1135	650	Chrome Coated Nikel Kaplama



**TURNSTILES &
BARRIERS**
TURNİKELER &
BARİYERLER

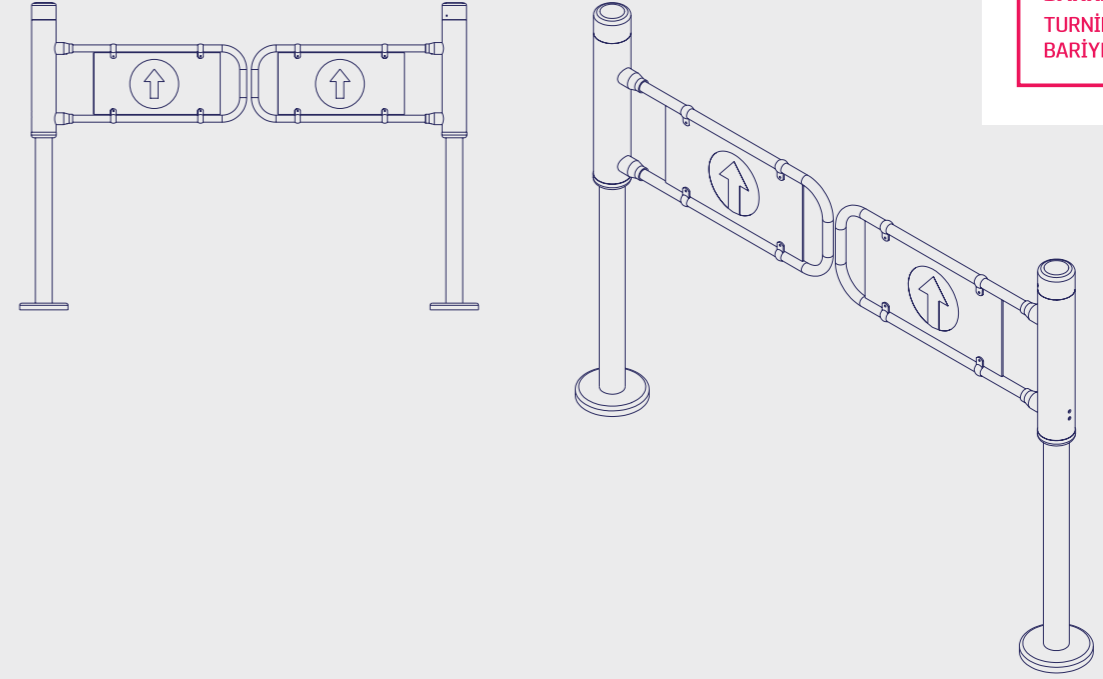

MECHANICAL TURNSTILE SET
DÖNER TURNİKE TAKIMI

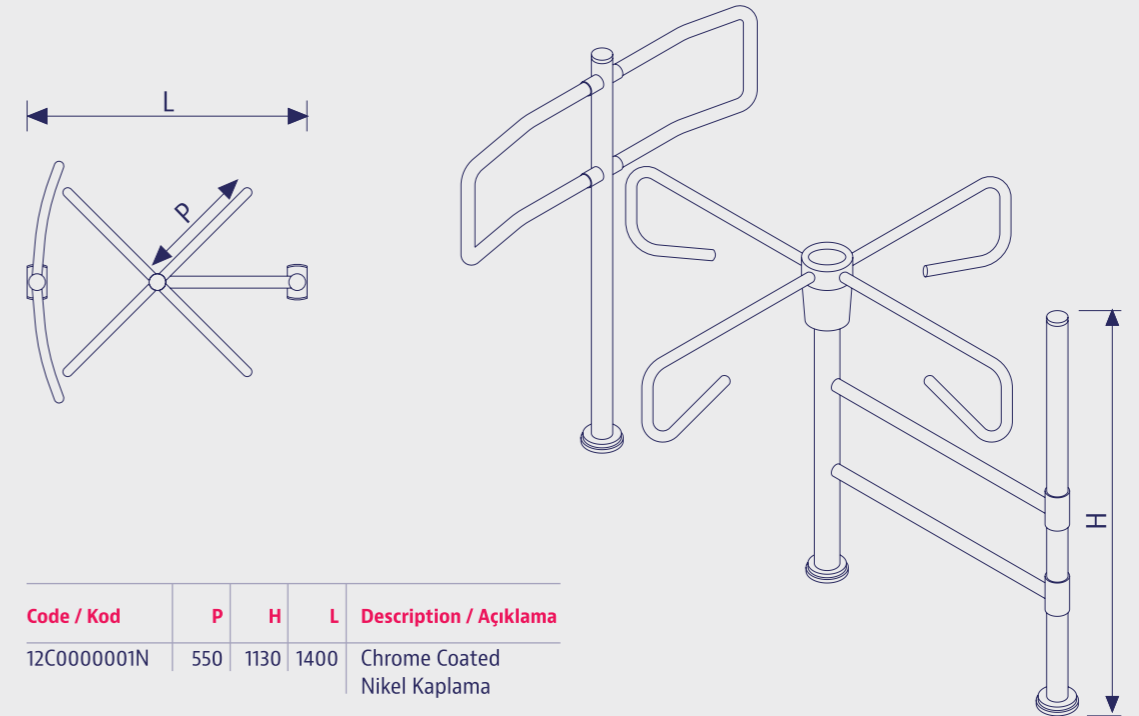

Code / Kod	P	H	L	Description / Açıklama
12C0000001N	550	1130	1400	Chrome Coated Nikel Kaplama



TURNSTILES & BARRIERS
TURNİKELER & BARİYERLER

ELECTRONIC SINGLE DOOR ACCESS GATE
FOTOSELLİ TEK KAPILI YAPRAK TURNİKE

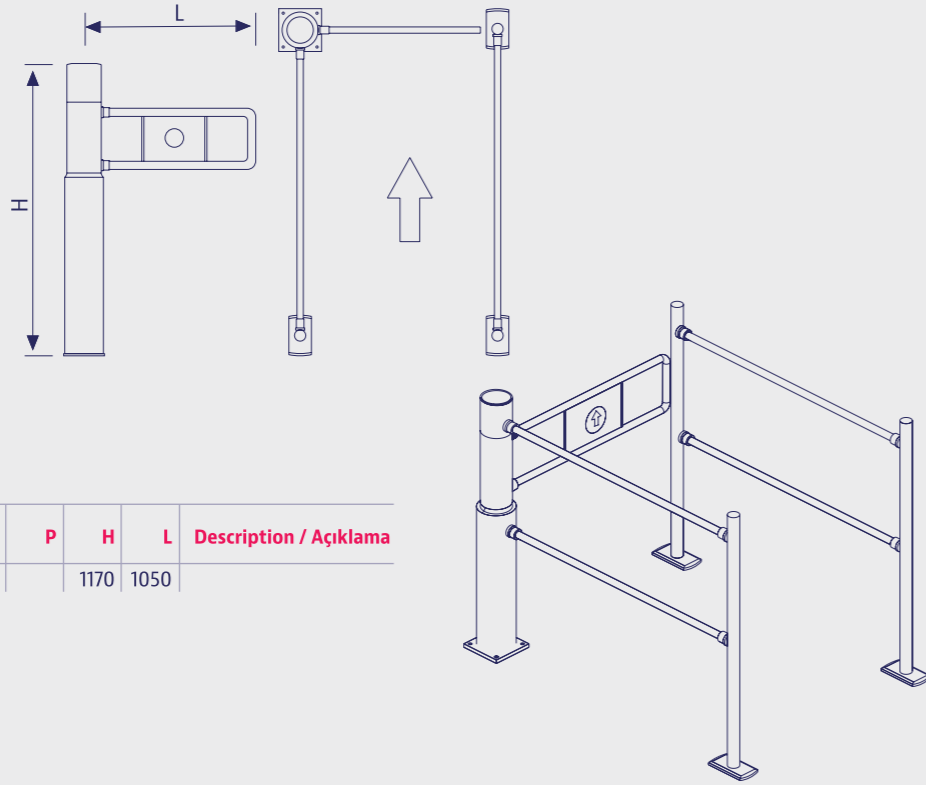

Code / Kod	P	H	L	Description / Açıklama
97000000055		1170	1050	

ELECTRONIC DOUBLE DOOR ACCESS GATE
FOTOSELLİ ÇİFT KAPILI YAPRAK TURNİKE

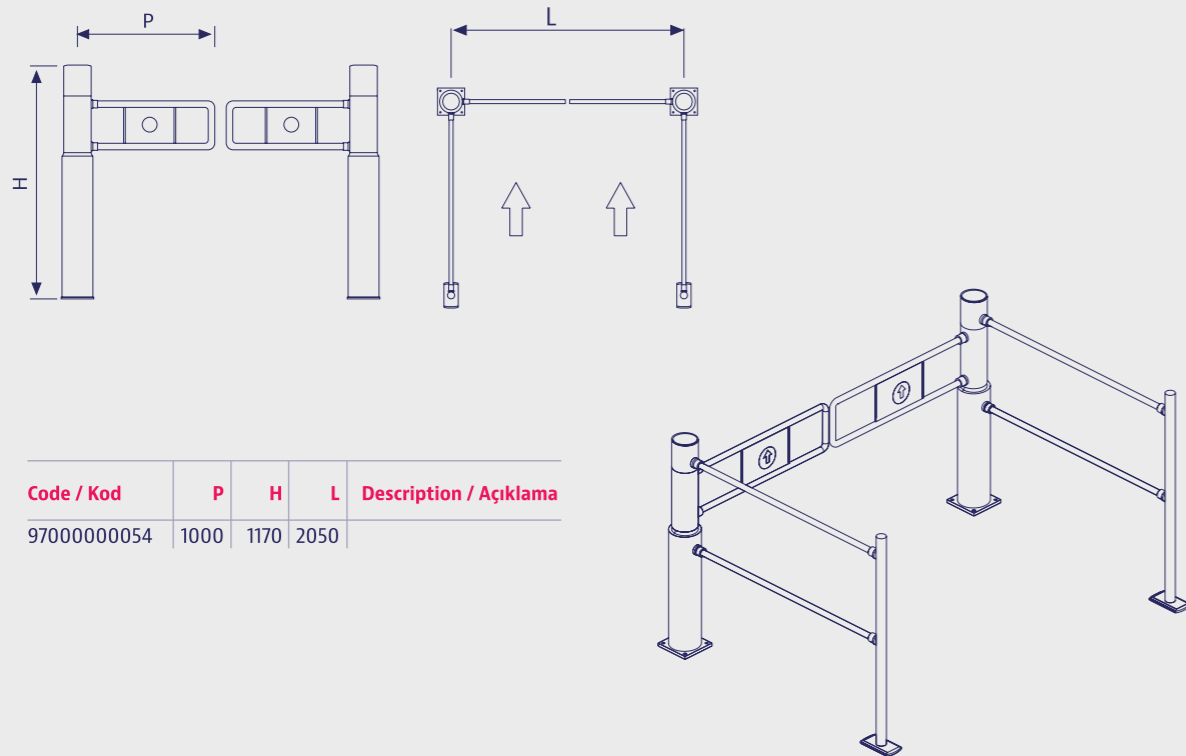

Code / Kod	P	H	L	Description / Açıklama
97000000054	1000	1170	2050	

BUMPER HOLDER FOR FLOOR - RIGHT
YER BARİYERİ TUTUCU SAĞ

Code / Kod	P	H	L	Description / Açıklama
12E0000001N		180		Chrome Coated Nikel Kaplama

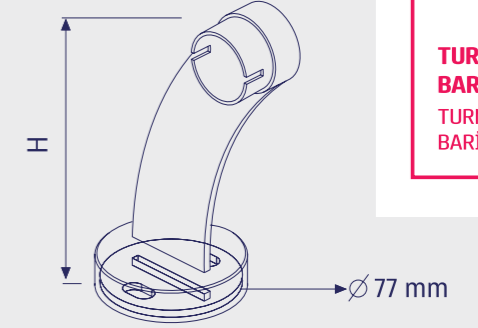

TURNSTILES & BARRIERS
TURNİKELER & BARİYERLER

BUMPER HOLDER FOR FLOOR - MIDDLE
YER BARİYERİ TUTUCU ORTA

Code / Kod	P	H	L	Description / Açıklama
12E0000003N		180		Chrome Coated Nikel Kaplama

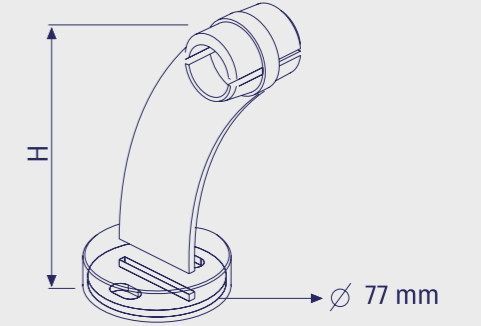

BUMPER HOLDER FOR FLOOR - LEFT
YER BARİYERİ TUTUCU SOL

Code / Kod	P	H	L	Description / Açıklama
12E0000002N		180		Chrome Coated Nikel Kaplama

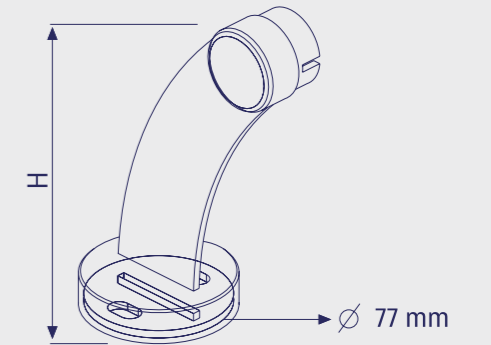

BUMPER FOR FLOOR
YER BARİYERİ BORUSU

Code / Kod	P	H	L	Description / Açıklama
12F0000001N			500	Chrome Coated Nikel Kaplama
12F0000002N			700	
12F0000003N			900	
12F0000004N			1000	
12F0000005N			1250	
12F0000006N			1330	





CHECK-OUT
KASAALTI





CHECK-OUT
KASAALTI

OPTIMAL CHECK - OUT WITH BELT
OPTİMAL BANTLI KASAALTI

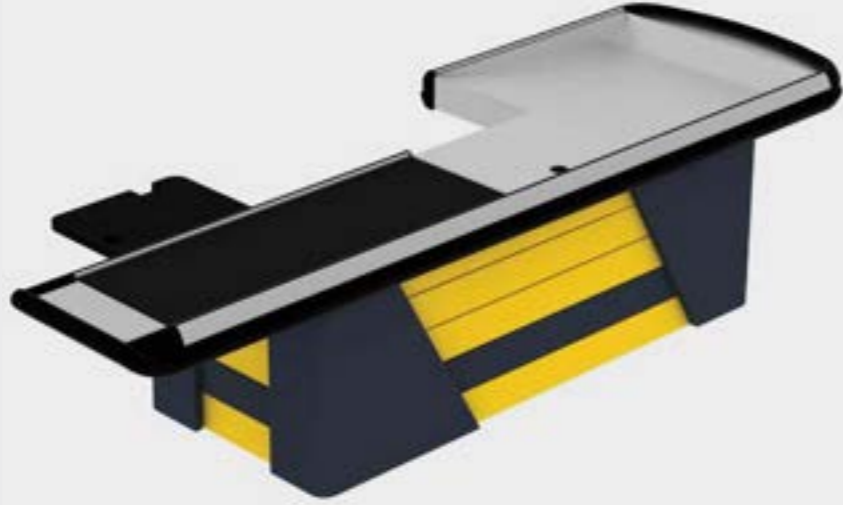

Code / Kod Right / Sağ	Code / Kod Left / Sol	A	B	C	L	W	W1	H	Description / Açıklama
18A0000005	18A0000006	720	475	755	2200	1050	1125	860	
18A0000009	18A0000010	720	575	755	2300	1050	1125	860	
18A0000056	18A0000057	820	575	755	2400	1050	1125	860	
18A0000001	18A0000002	820	475	955	2500	1050	1125	860	
18A0000013	18A0000014	820	575	955	2600	1050	1125	860	
18A0000017	18A0000018	920	575	955	2700	1050	1125	860	
18A0000058	18A0000051	920	575	1155	2900	1050	1125	860	
18A0000059	18A0000060	1120	575	1155	3100	1050	1125	860	

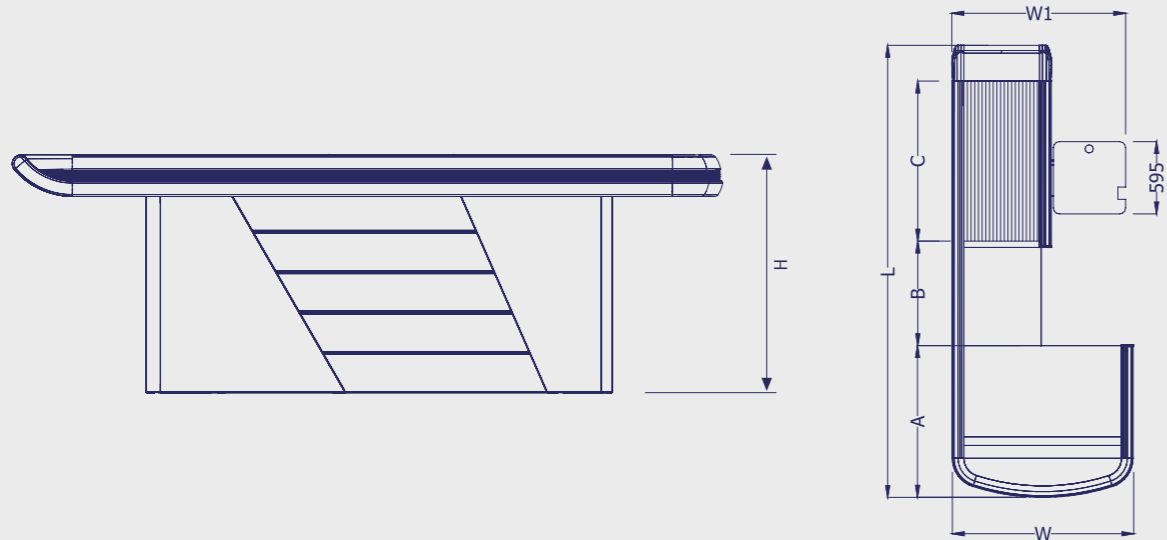

CHECK-OUT
KASAALTI

OPTIMAL CHECK - OUT WITHOUT BELT
OPTİMAL BANTSIZ KASAALTI



Code / Kod Right / Sağ	Code / Kod Left / Sol	A	B	C	L	W	W1	H	Description / Açıklama
18A0000011	18A0000012	720	430	950	2100	1050	1125	860	
18A0000015	18A0000016	720	430	1050	2200	1050	1125	860	
18A0000061	18A0000062	720	530	1050	2300	1050	1125	860	
18A0000063	18A0000064	820	530	1050	2400	1050	1125	860	
18A0000003	18A0000004	820	530	1150	2500	1050	1125	860	
18A0000027	18A0000028	820	530	1250	2600	1050	1125	860	
18A0000065	18A0000066	920	530	1250	2700	1050	1125	860	
18A0000067	18A0000068	1020	530	1350	2900	1050	1125	860	

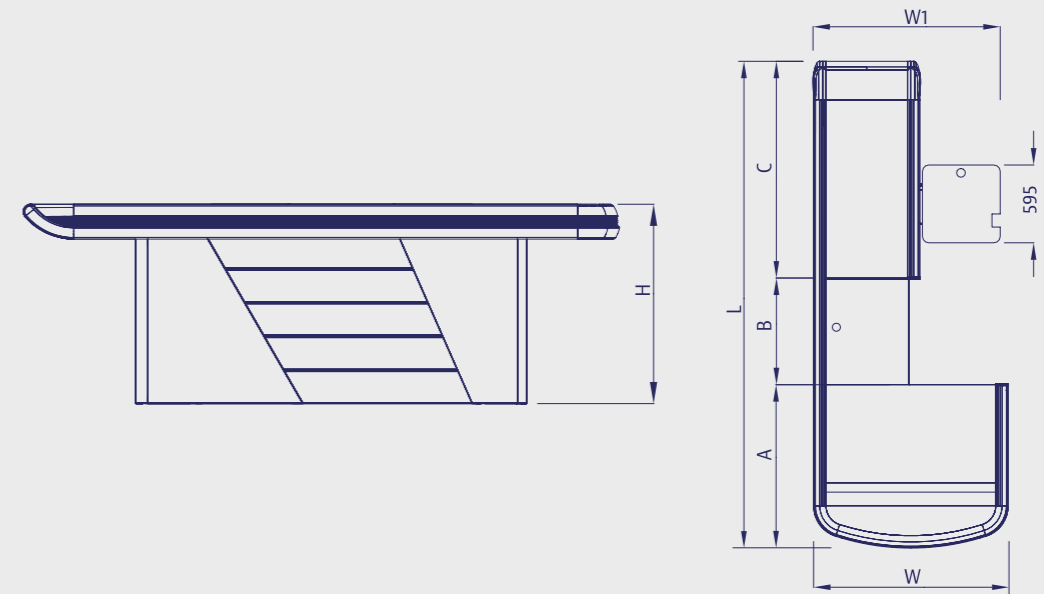



CHECK-OUT
KASAALTI

OPTIMAL TANDEM CHECK - OUT WITH BELT
OPTİMAL TANDEM BANTLI KASAALTI

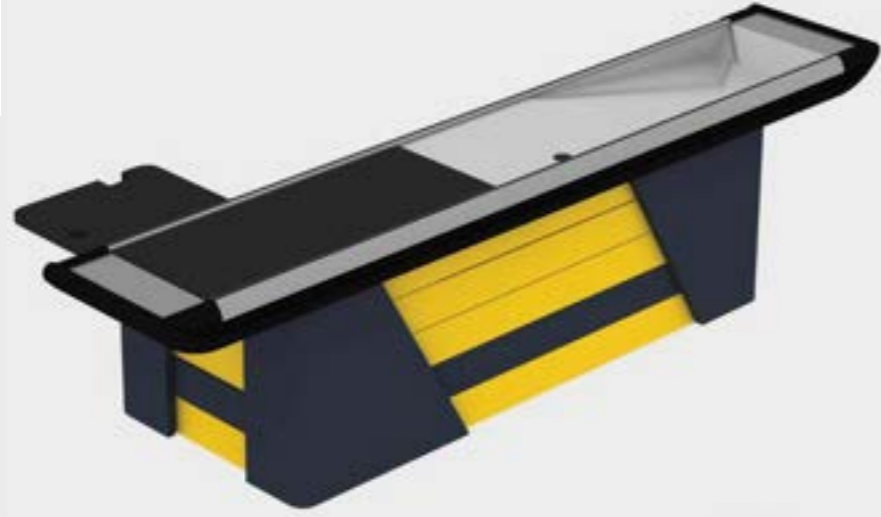

Code / Kod Right / Sağ	Code / Kod Left / Sol	A	B	C	L	W	W1	H	Description / Açıklama
18A0000035	18A0000036	720	475	755	2200	580	1125	860	
18A0000033	18A0000034	720	575	755	2300	580	1125	860	
18A0000069	18A0000070	820	575	755	2400	580	1125	860	
18A0000031	18A0000032	820	475	955	2500	580	1125	860	
18A0000071	18A0000072	820	575	955	2600	580	1125	860	
18A0000029	18A0000030	920	575	955	2700	580	1125	860	
18A0000073	18A0000074	920	575	1155	2900	580	1125	860	
18A0000075	18A0000076	1120	575	1155	3100	580	1125	860	

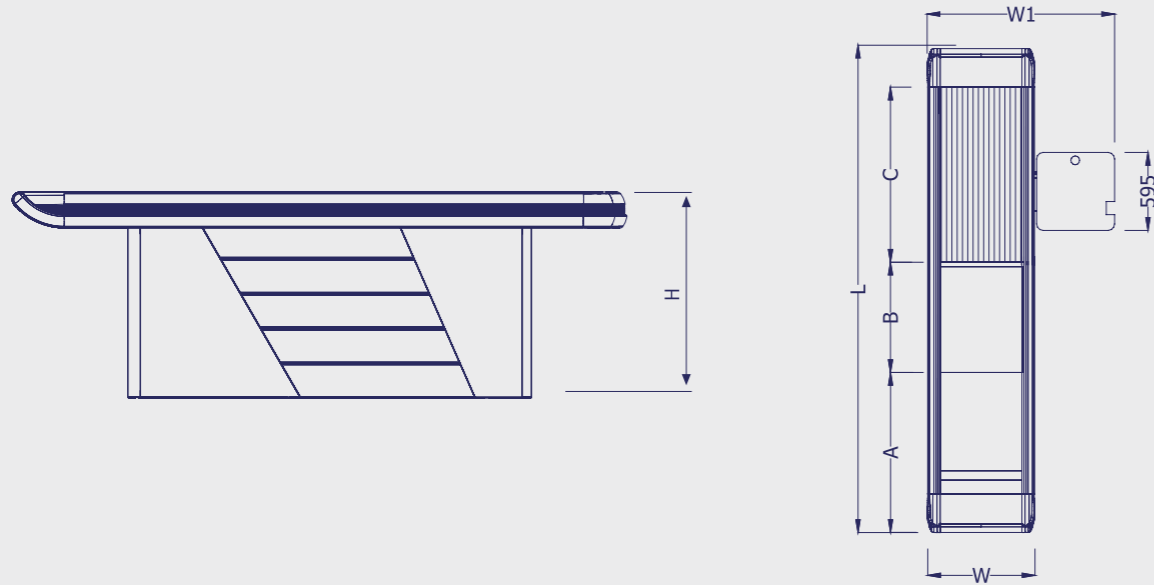

CHECK-OUT
KASAALTI

OPTIMAL TANDEM CHECK - OUT WITHOUT BELT
OPTİMAL TANDEM BANTSIZ KASAALTI

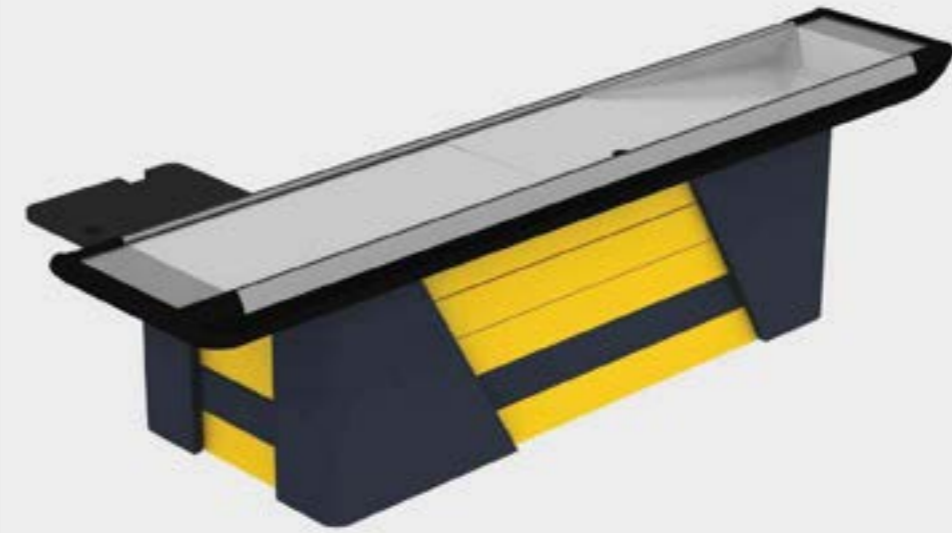

Code / Kod Right / Sağ	Code / Kod Left / Sol	A	B	C	L	W	W1	H	Description / Açıklama
18A0000043	18A0000044	720	430	950	2100	580	1125	860	
18A0000041	18A0000042	720	430	1050	2200	580	1125	860	
18A0000077	18A0000078	720	530	1050	2300	580	1125	860	
18A0000079	18A0000080	820	530	1050	2400	580	1125	860	
18A0000039	18A0000040	820	530	1150	2500	580	1125	860	
18A0000037	18A0000038	820	530	1250	2600	580	1125	860	
18A0000081	18A0000082	920	530	1250	2700	580	1125	860	

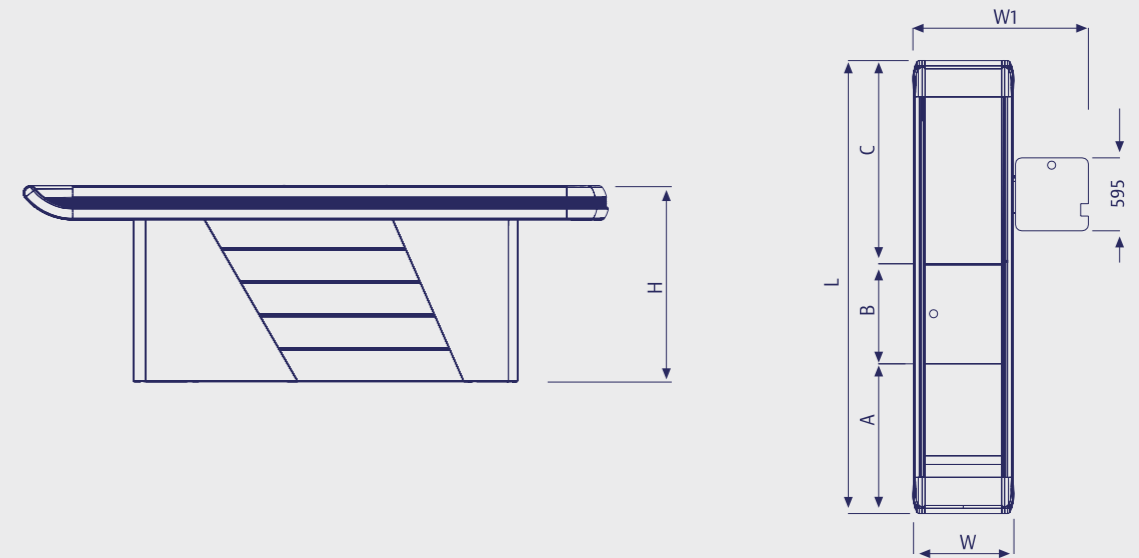



CHECK-OUT
KASAALTI

DUAL CHECK - OUT WITH BELT
İKİLİ KASAALTI BANTLI



Code / Kod	A	B	C	A1	B1	C1	L	W	W1	H	Description / Açıklama
1810000001	1350	575	725	720	575	1355	2900	580	1900	860	
1810000002	1350	575	825	820	575	1555	3100	580	1900	860	
1810000003	1520	575	955	920	575	1555	3300	580	1900	860	
1810000004	1520	575	1355	920	575	1955	3700	580	1900	860	
1810000005	1420	575	1855	1020	575	2250	4100	580	1900	860	

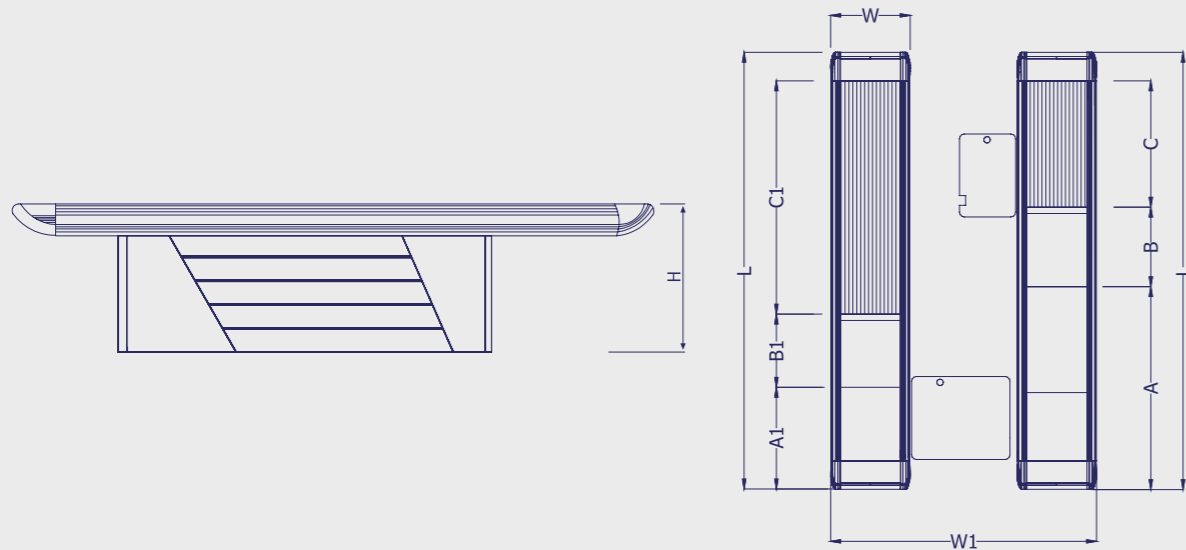

CHECK-OUT
KASAALTI

TWIN CHECK - OUT WITH BELT
İKİZ KASAALTI BANTLI

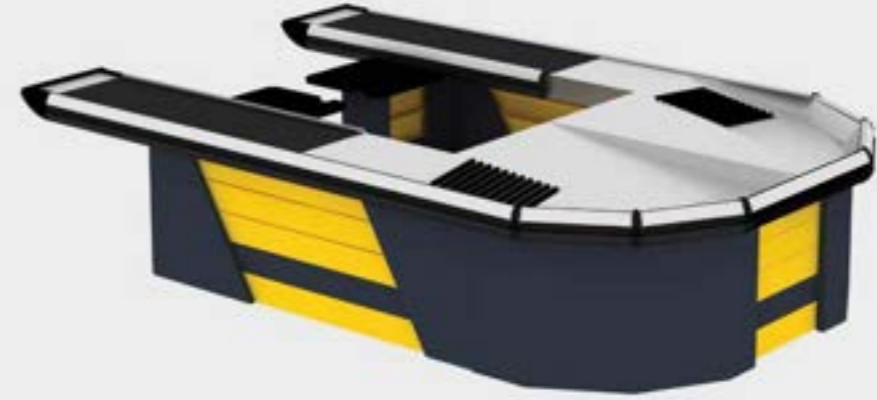

Code / Kod	A	B	C	L	W	W1	H	Description / Açıklama
18T0000004	940	475	835	2500	2410		860	
18T0000005	940	575	935	2700	2410		860	
18T0000006	1300	575	1225	3350	2410		860	
18T0000003	1300	575	1425	3550	2410		860	
18T0000002	1300	575	1625	3750	2410		860	
18T0000007	1300	675	1725	3950	2410		860	
18T0000008	1300	575	2025	4150	2410		860	

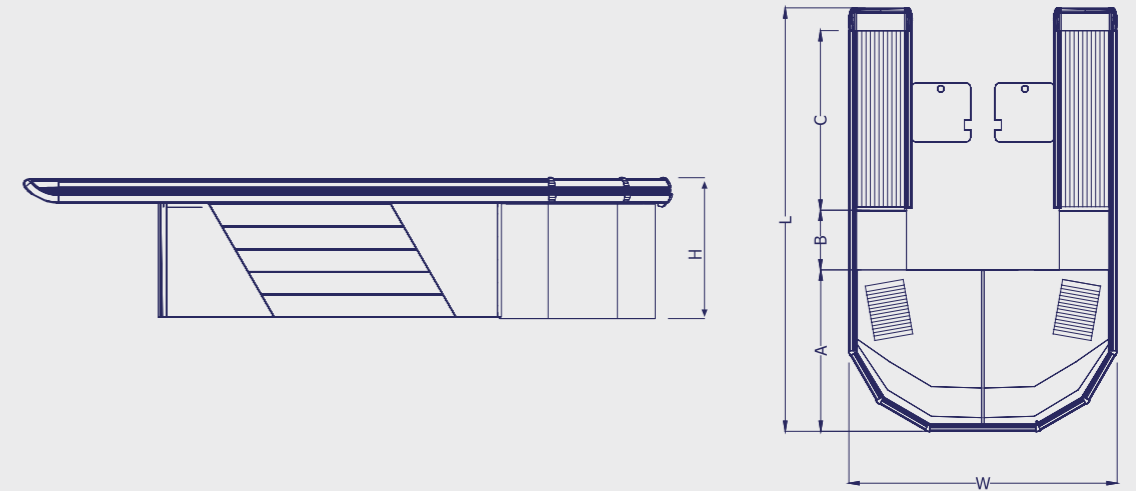



CHECK-OUT
KASAALTI

■ CHECK - OUT WITH BELT - COOL SERIES
BANTLI KASAALTI - COOL SERİSİ



Code / Kod Right / Sağ	Code / Kod Left / Sol	A	B	C	L	W	W1	H	Description / Açıklama
18C0000005	18C0000006	550	575	747	2000	1030	1120	860	
18C0000007	18C0000008	550	575	847	2100	1030	1120	860	
18C0000009	18C0000010	650	575	847	2200	1030	1120	860	
18C0000011	18C0000012	750	575	847	2300	1030	1120	860	
18C0000001	18C0000002	750	575	1047	2500	1030	1120	860	
18C0000013	18C0000014	750	575	1247	2700	1030	1120	860	
18C0000015	18C0000016	1050	575	1447	3200	1030	1120	860	

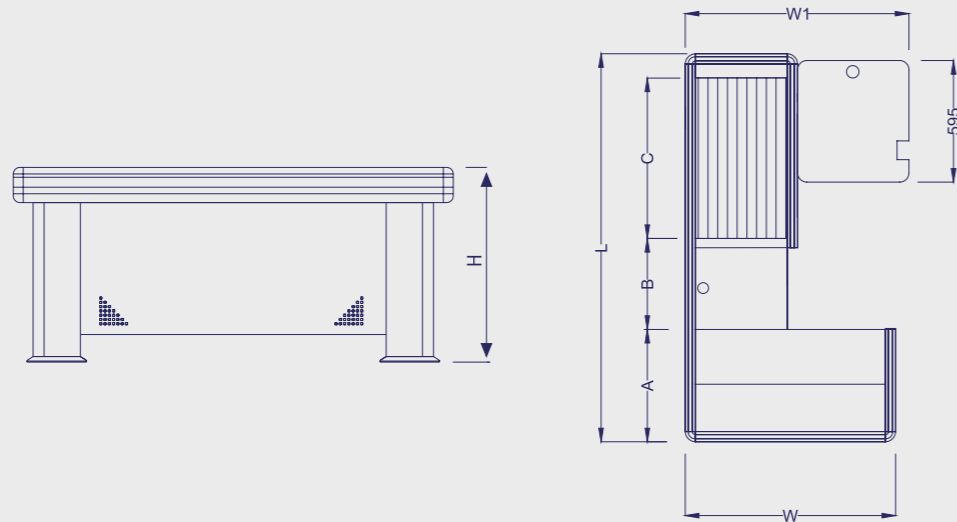

CHECK-OUT
KASAALTI

■ CHECK - OUT WITH OUT BELT - COOL SERIES
BANTSIZ KASAALTI - COOL SERİSİ



Code / Kod Right / Sağ	Code / Kod Left / Sol	A	B	C	L	W	W1	H	Description / Açıklama
18C0000027	18C0000028	550	530	820	1900	1030	1120	860	
18C0000025	18C0000026	550	530	920	2000	1030	1120	860	
18C0000023	18C0000024	550	530	1020	2100	1030	1120	860	
18C0000021	18C0000022	550	530	1120	2200	1030	1120	860	
18C0000019	18C0000020	650	530	1120	2300	1030	1120	860	
18C0000017	18C0000018	650	530	1220	2400	1030	1120	860	
18C0000003	18C0000004	750	530	1220	2500	1030	1120	860	

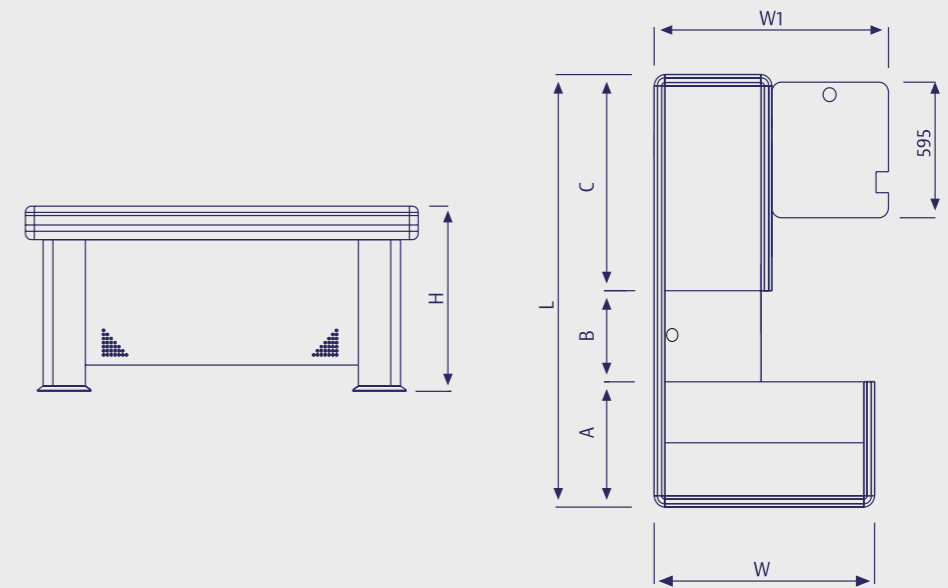



CHECK-OUT
KASAALTI

TANDEM CHECK - OUT WITH BELT COOL SERIES
TANDEM BANTLI KASAALTI COOL SERİSİ

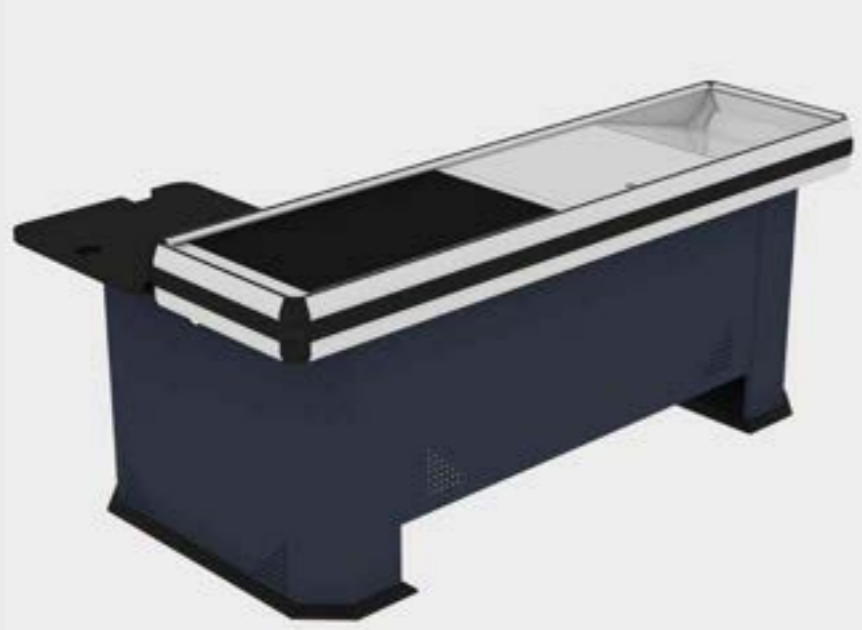

Code / Kod Right / Sağ	Code / Kod Left / Sol	A	B	C	L	W	W1	H	Description / Açıklama
18C0000043	18C0000044	550	575	747	2000	550	1120	860	
18C0000041	18C0000042	650	575	747	2100	550	1120	860	
18C0000039	18C0000040	650	575	847	2200	550	1120	860	
18C0000037	18C0000038	650	575	947	2300	550	1120	860	
18C0000033	18C0000034	750	575	1047	2500	550	1120	860	
18C0000035	18C0000036	750	575	1247	2700	550	1120	860	

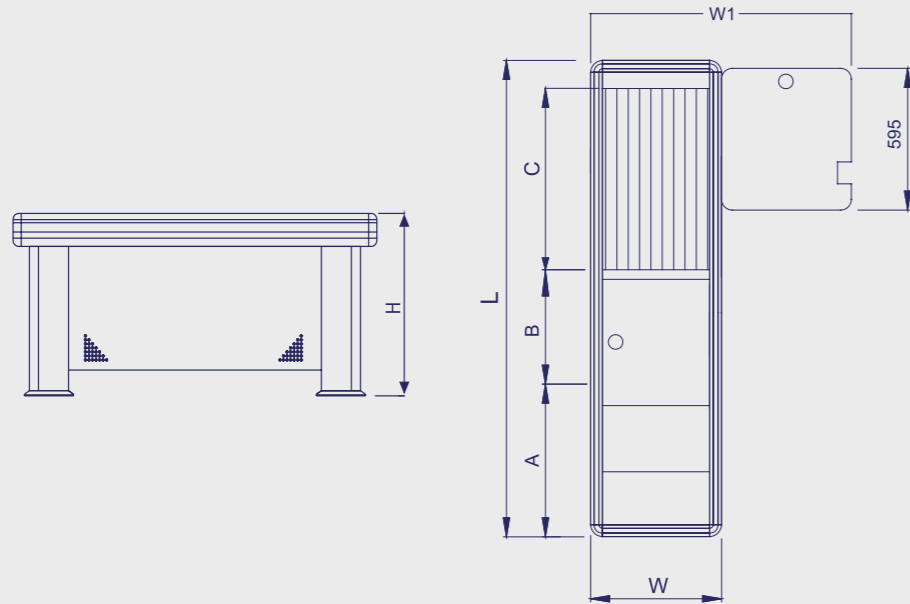

CHECK-OUT
KASAALTI

TANDEM CHECK - OUT WITHOUT BELT - COOL SERIES
TANDEM BANTSIZ KASAALTI - COOL SERİSİ



Code / Kod Right / Sağ	Code / Kod Left / Sol	A	B	C	L	W	W1	H	Description / Açıklama
18C0000055	18C0000056	550	530	820	1900	550	1120	860	
18C0000053	18C0000054	550	530	920	2000	550	1120	860	
18C0000051	18C0000052	650	530	875	2100	550	1120	860	
18C0000071	18C0000072	750	530	975	2200	550	1120	860	
18C0000049	18C0000050	750	530	1020	2300	550	1120	860	
18C0000047	18C0000048	750	530	1220	2500	550	1120	860	
18C0000045	18C0000046	850	530	1320	2700	550	1120	860	

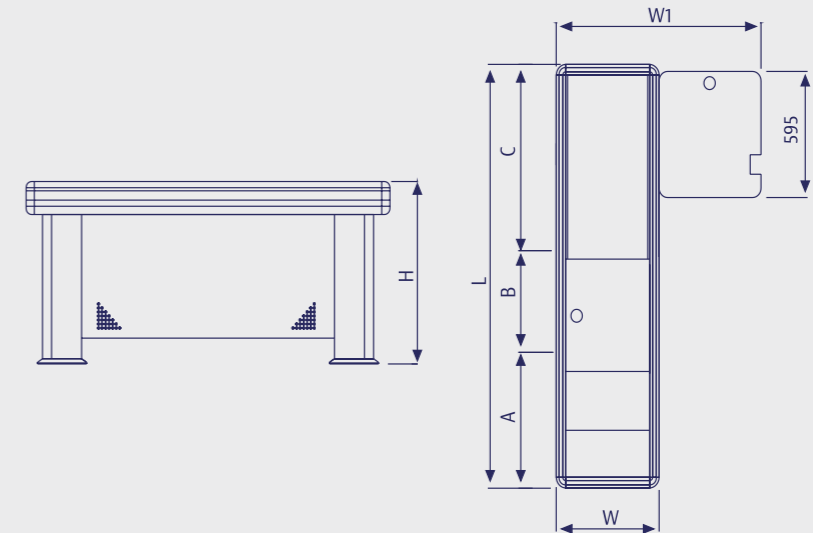



CHECK-OUT
KASAALTI

TANDEM CHECK - OUT WITHOUT BELT - COOL SERIES
KÜÇÜK BANTSIZ KASAALTI - COOL SERİSİ



Code / Kod Right / Sağ	Code / Kod Left / Sol	A	B	L	W	W1	H	Description / Açıklama
18C0000065	18C0000066	550	650	1200	550	1120	860	
18C0000059	18C0000060	550	950	1500	550	1120	860	
18C0000057	18C0000058	550	1100	1650	550	1120	860	

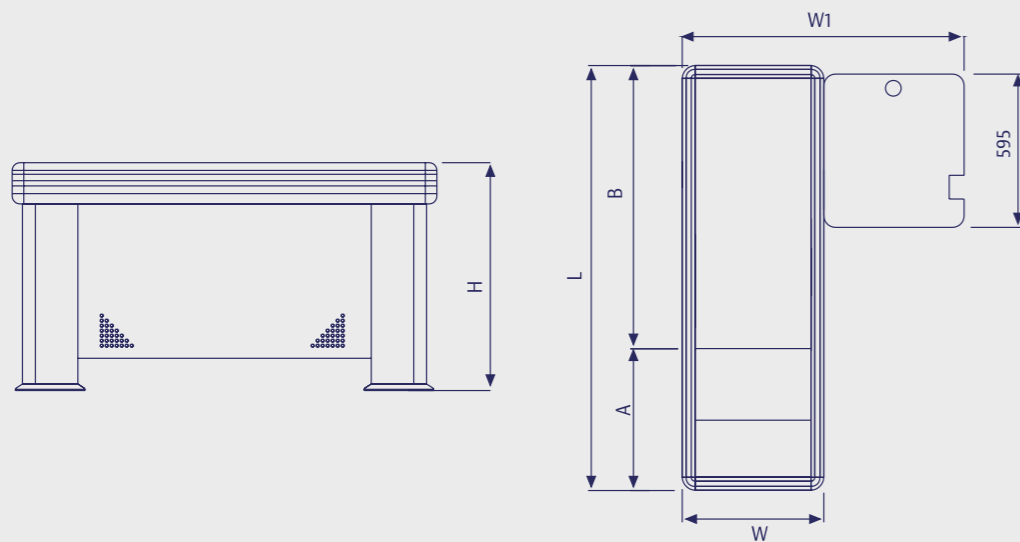

CHECK-OUT
KASAALTI

TWIST CHECK-OUT WITH BELT
TWIST BANTLI KASAALTI



Code / Kod Right / Sağ	Code / Kod Left / Sol	A	B	C	L	W	W1	H	Description / Açıklama
18T0000009	18T0000023	720	700	780	2200	580	1125	860	
18T0000010	18T0000024	720	700	880	2300	580	1125	860	
18T0000011	18T0000025	720	700	980	2400	580	1125	860	
18T0000012	18T0000026	720	700	1080	2500	580	1125	860	
18T0000013	18T0000027	720	700	1180	2600	580	1125	860	
18T0000014	18T0000028	720	700	1280	2700	580	1125	860	
18T0000015	18T0000029	720	700	1680	3100	580	1125	860	

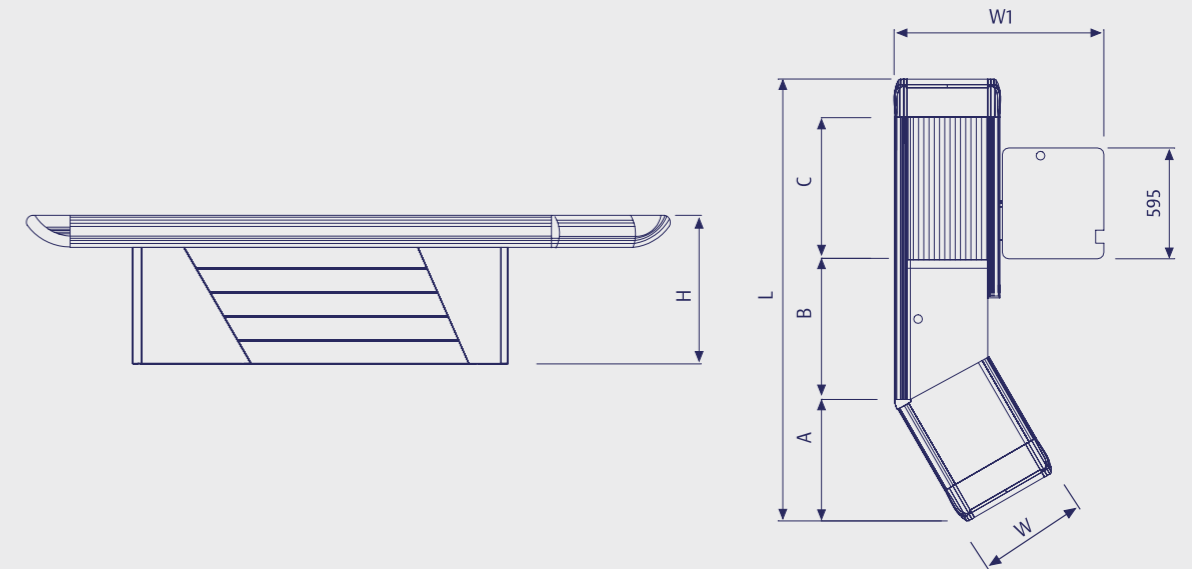



CHECK-OUT
KASAALTI

TWIST CHECK-OUT WITHOUT BELT
TWIST BANTSIZ KASAALTI



Code / Kod Right / Sağ	Code / Kod Left / Sol	A	B	C	L	W	W1	H	Description / Açıklama
18T0000016	18T0000030	720	700	780	2200	580	1125	860	
18T0000017	18T0000031	720	700	880	2300	580	1125	860	
18T0000018	18T0000032	720	700	980	2400	580	1125	860	
18T0000019	18T0000033	720	700	1080	2500	580	1125	860	
18T0000020	18T0000034	720	700	1180	2600	580	1125	860	
18T0000021	18T0000035	720	700	1280	2700	580	1125	860	
18T0000022	18T0000036	720	700	1680	3100	580	1125	860	

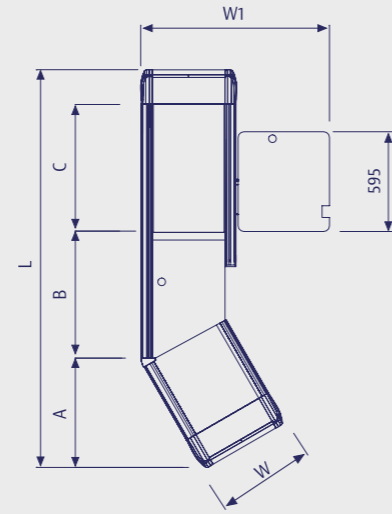
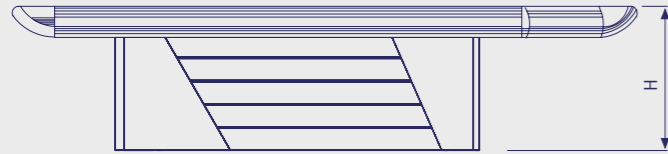

CHECK-OUT
KASAALTI

EXPRESS CHECK-OUT TİPE 1
EKSPRES KASAALTI TİP 1

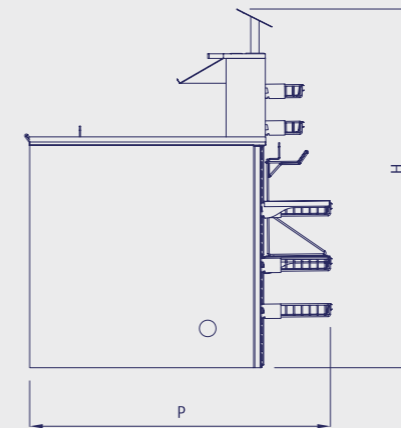
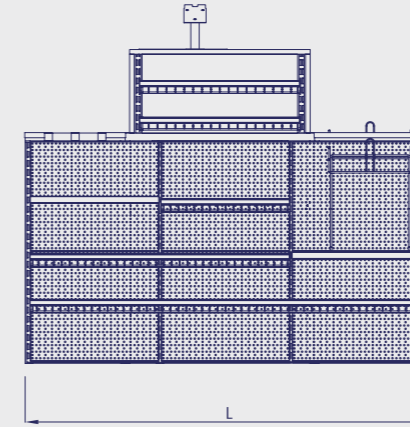
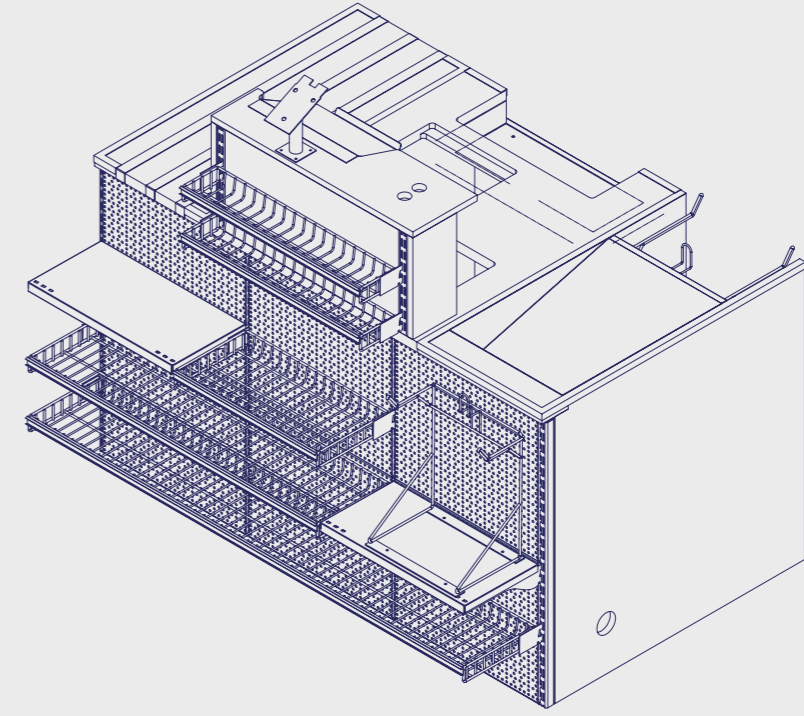

Code / Kod Right / Sağ	Code / Kod Left / Sol	P	H	L	Description / Açıklama
18E0000001	18E0000002	1150	1370	1530	*Front Panels Are Perforated *Ön Paneller Delikli Arka Sac

Accessories / Aksesuarlar

11F0000123N	PG Kasa Önü Sepet Raf 125x610
11F0000124N	PG Kasa Önü Sepet Raf 250x500
11F0000125N	PG Kasa Önü Sepet Raf 250x1000
11F0000126N	PG Kasa Önü Sepet Raf 250x1500
5E00000003B	Kendinden Yanaklı Raf 150x500



CHECK-OUT
KASAALTI

EXPRESS CHECK-OUT TYPE 2
EKSPRES KASAALTI TİP 2

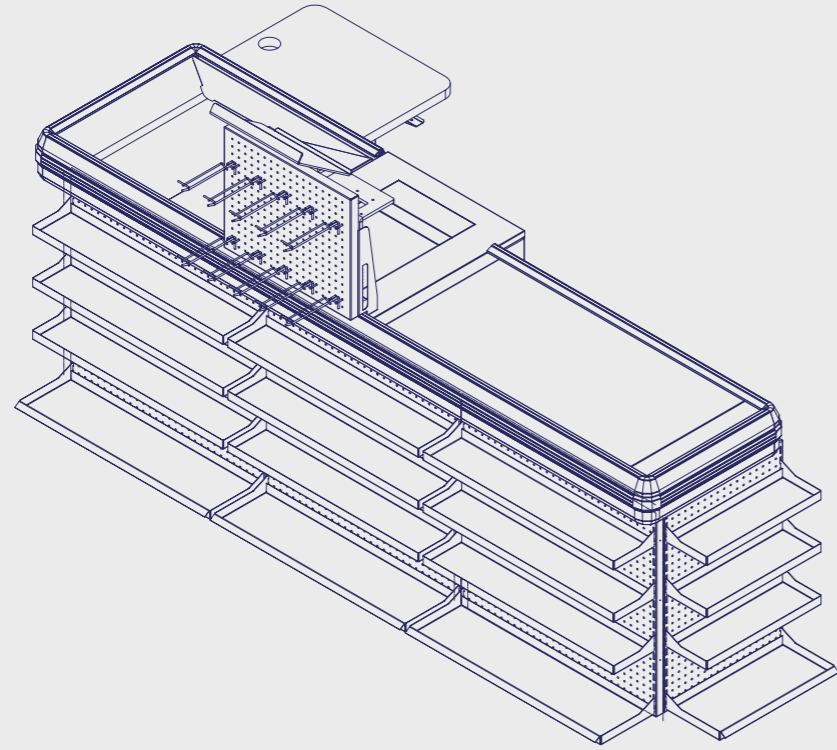

Code / Kod Right / Sağ	Code / Kod Left / Sol	P	H	L	Description / Açıklama
18S00000015	18S00000025	1250	1335	2400	*Front Panels Are Perforated *Ön Paneller Delikli Arka Sac

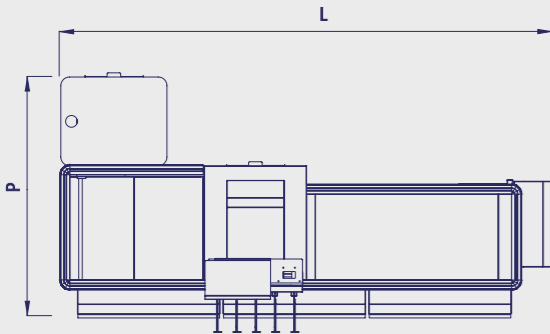
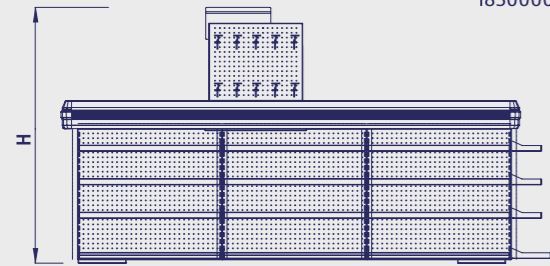

Accessories / Aksesuarlar

5L00000001B	Tava Raf Etk.li 444x200
5L00000002B	Tava Raf Etk.li 444x150
5L00000003B	Tava Raf Etk.li 739x200
5L00000004B	Tava Raf Etk.li 739x150
11C0000008N	Dsg Etk.li Spot Tel P: 100 N



CHECK-OUT
KASAALTI

EXPRESS CHECK-OUT TYPE3
EKSPRES KASAALTI TİP 3

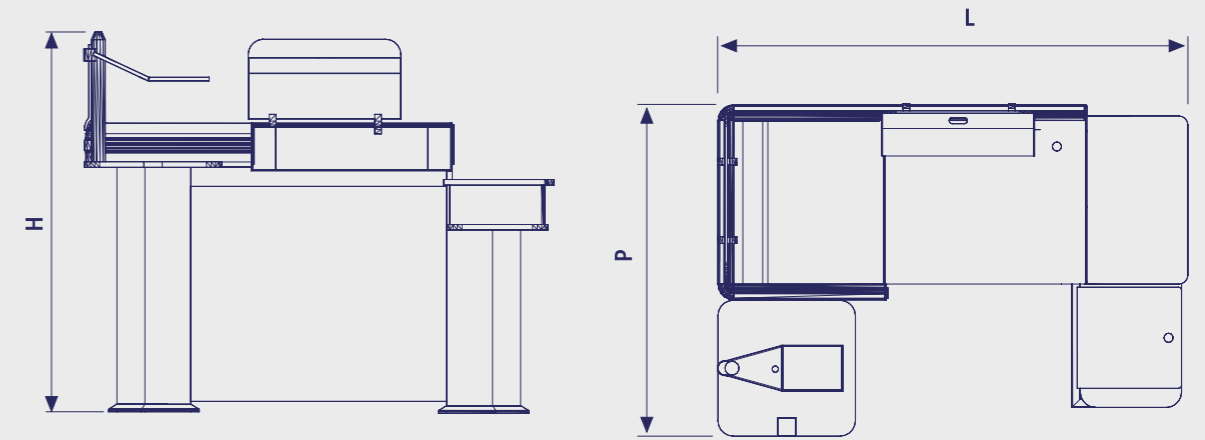

Code / Kod Right / Sağ	Code / Kod Left / Sol	P	H	L	Description / Açıklama
18E0000006	18E0000007	1000	1500	1450	



CHECK-OUT
KASAALTI

EXPRESS CHECK-OUT TYPE 4
EKSPRES KASAALTI TİP 4

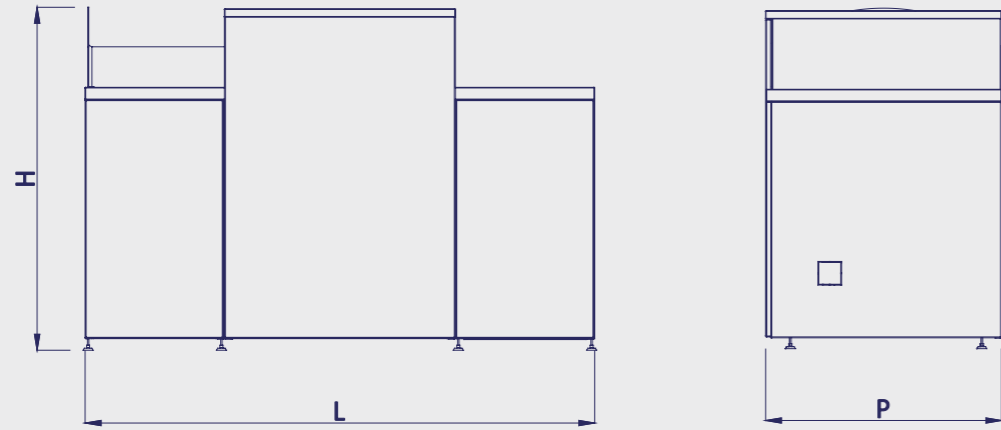
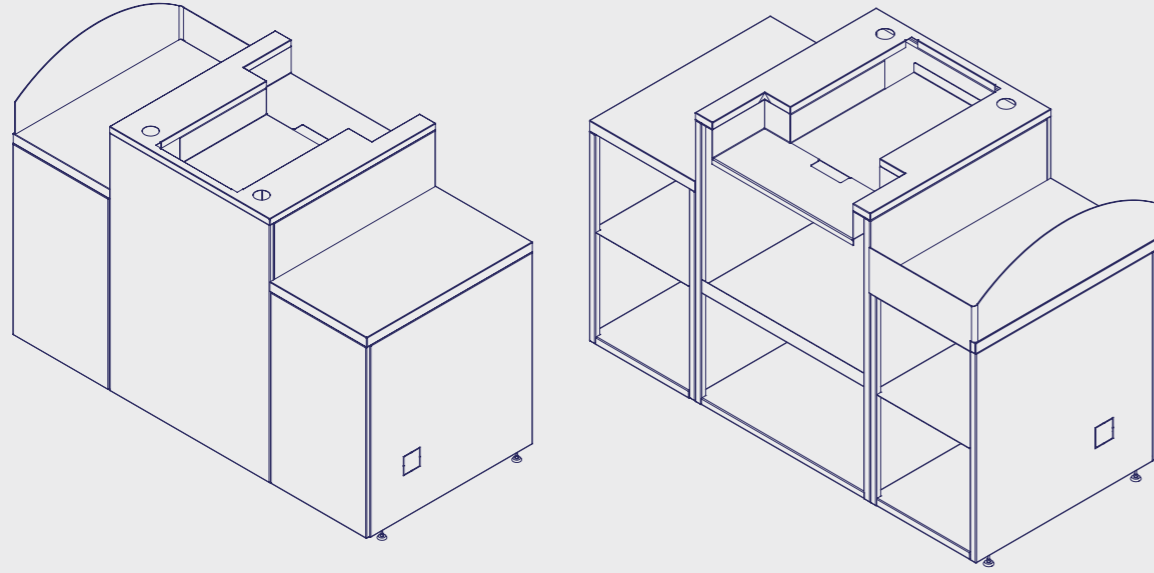

Code / Kod Right / Sağ	Code / Kod Left / Sol	P	H	L	Description / Açıklama
18ME000001	18ME000002	600	1280	860	18ME000001 Sağ Kapalı 18ME000002 Sol Kapalı



CHECK-OUT
KASAALTI

EXPRESS CHECK-OUT TYPE 5
EKSPRES KASAALTI TİP 5

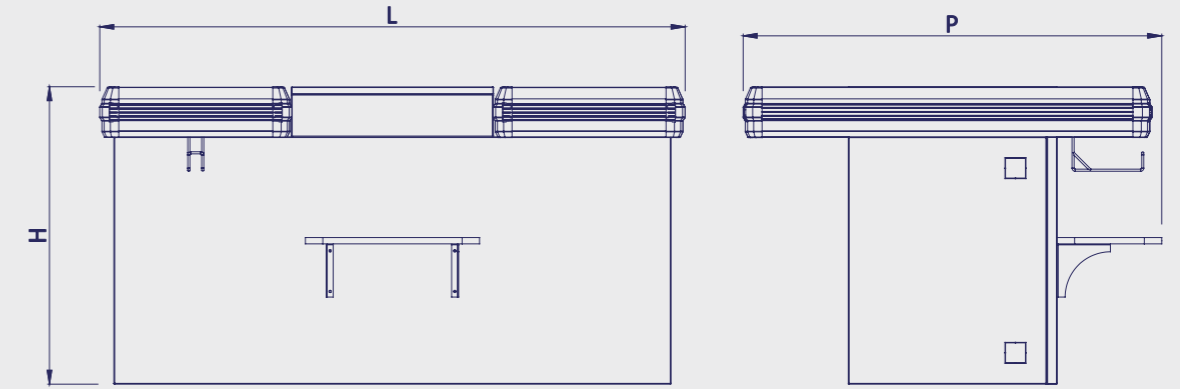

Code / Kod Right / Sağ	Code / Kod Left / Sol	P	H	L	Description / Açıklama
18E0000008	18E0000009	1200	850	1680	



CHECK-OUT
KASAALTI

CHECK-OUT GONDOLA TYPE 1
KASA ÖNÜ STANDI TİP 1

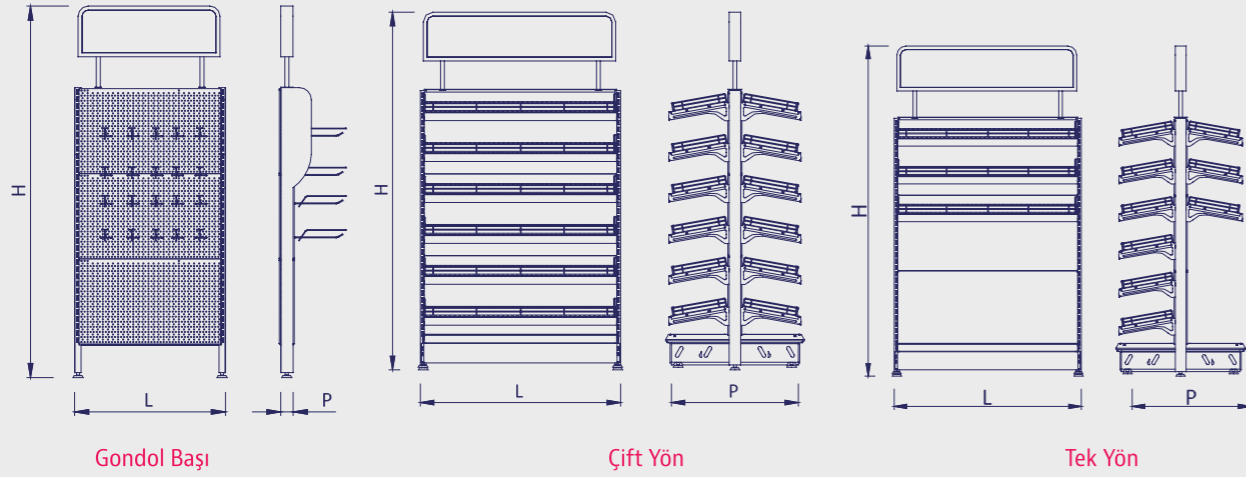
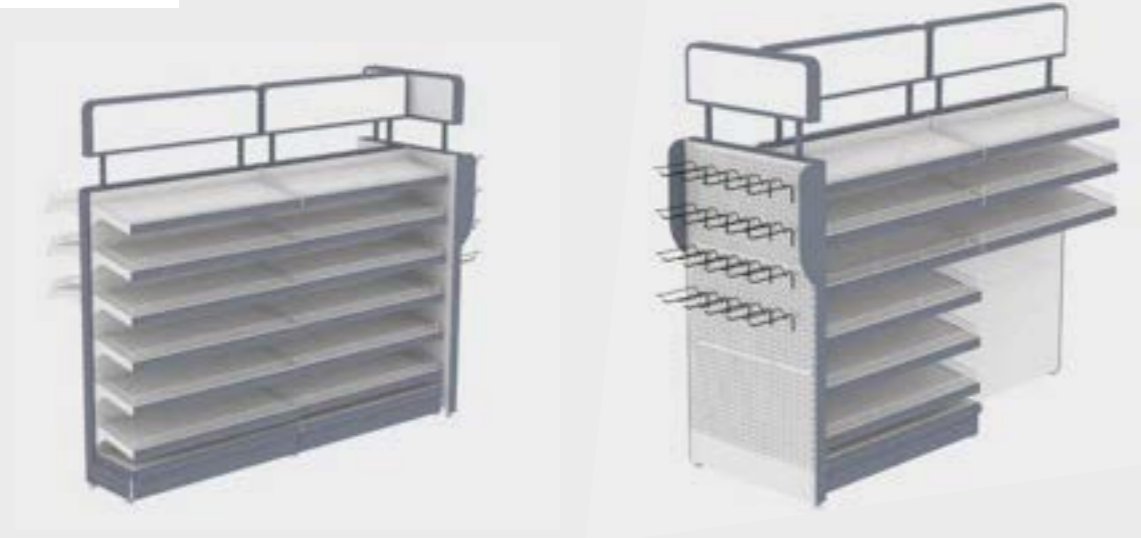

Code / Kod	P	H	L	Description / Açıklama
8B00000027U	660	1830	730	Gondol Başı
8B00000028U	660	1830	1030	Tek Yön
8B00000029U	660	1830	1030	Çift Yön



CHECK-OUT
KASAALTI

CHECK-OUT GONDOLA TYPE 2
KASA ÖNÜ STANDI TİP 2

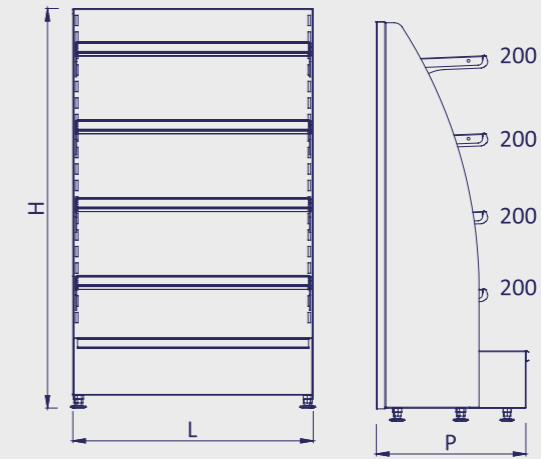

Code / Kod	P	H	L	Description / Açıklama
8B00000030U	300	1010	1060	



CHECK-OUT
KASAALTI

REPLA CHECK-OUT GONDOLA
REPLA FONKSİYONEL TEŞHİR STANDI

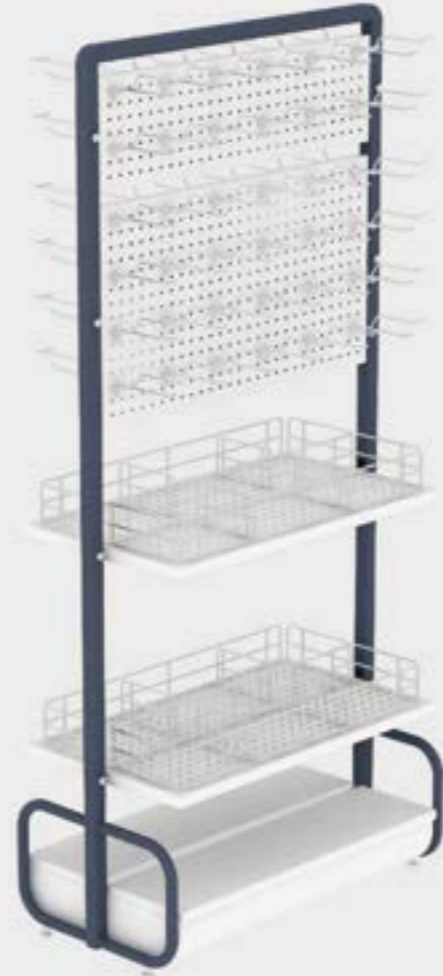
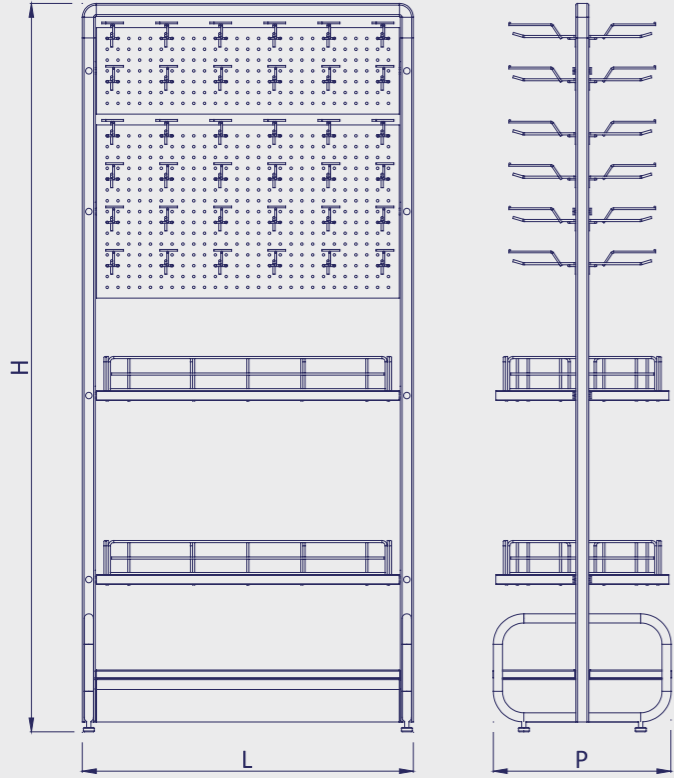

Code / Kod	P	H	L	Description / Açıklama
8B00000032U	410	1680	765	Aksesuarlar müşteri isteğine göre değişiklik gösterebilir.

CHECK-OUT GONDOLA TYPE 3
KASA ÖNÜ STANDI TİP 3

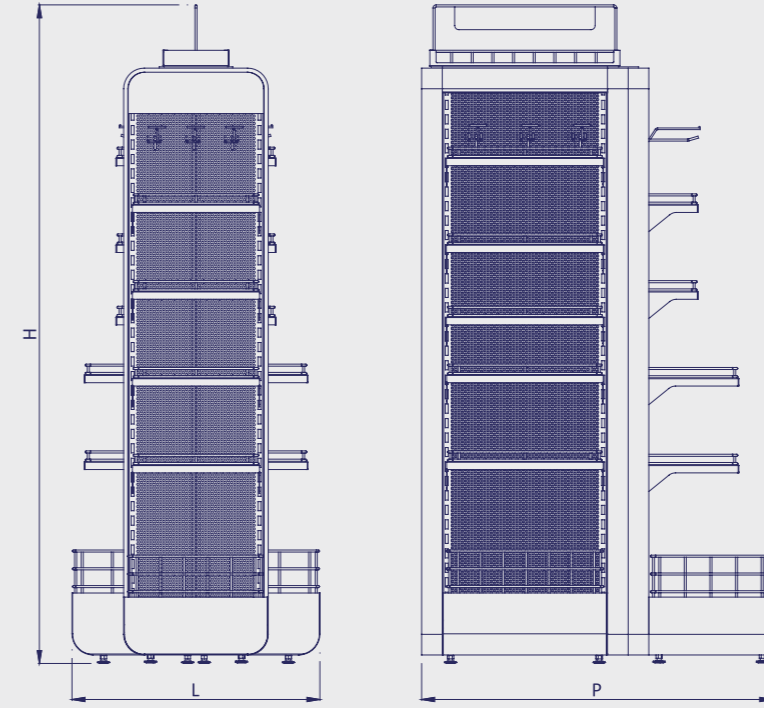

Code / Kod	P	H	L	Description / Açıklama
8B00000031U	850	1595	600	

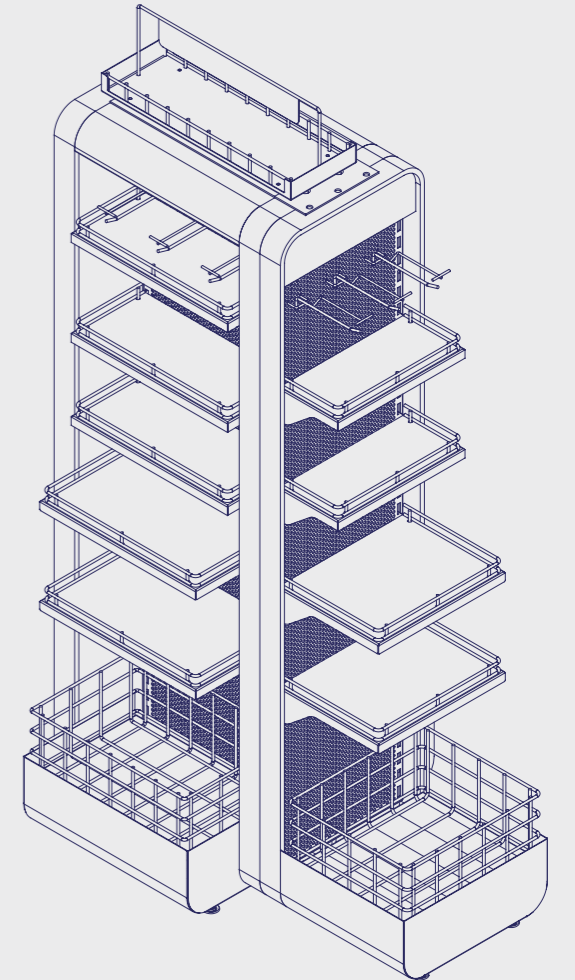

CHECK-OUT
KASAALTI



CHECK-OUT
KASAALTI

SAMPLE UNITS FOR CHECK OUT GONDOLA
ÖRNEK KASA ÖNÜ GONDOLLARI

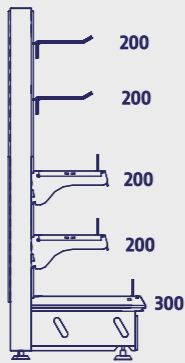
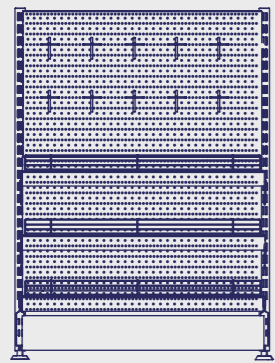
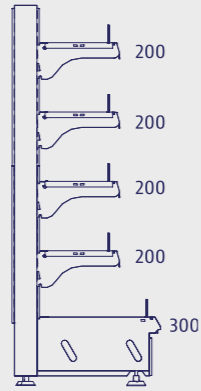
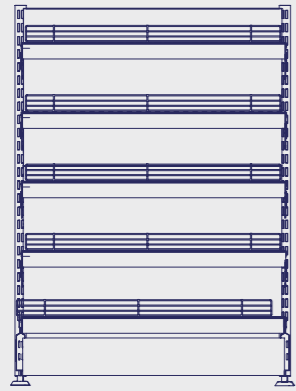

CHECK-OUT
KASAALTI

SAMPLE UNITS FOR CHECK OUT GONDOLA
ÖRNEK KASA ÖNÜ GONDOLLARI

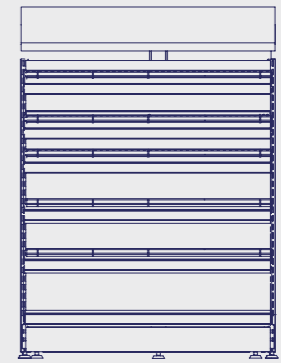
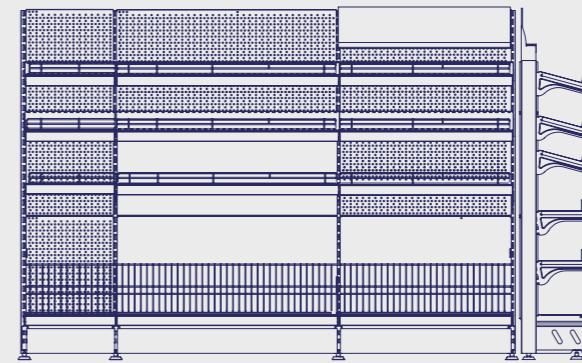
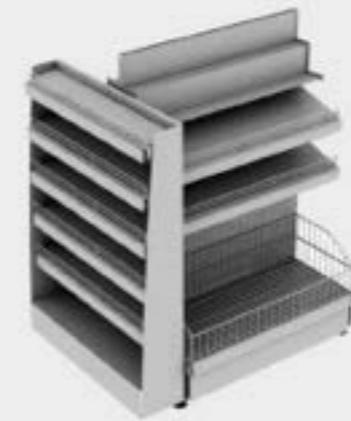
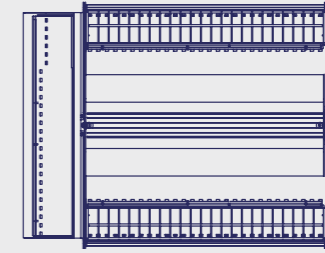
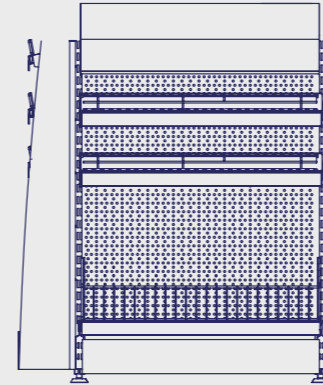



CHECK-OUT
KASAALTI

LONG POLE FOR CABINET
ALUMİNYUM KASA DİREĞİ

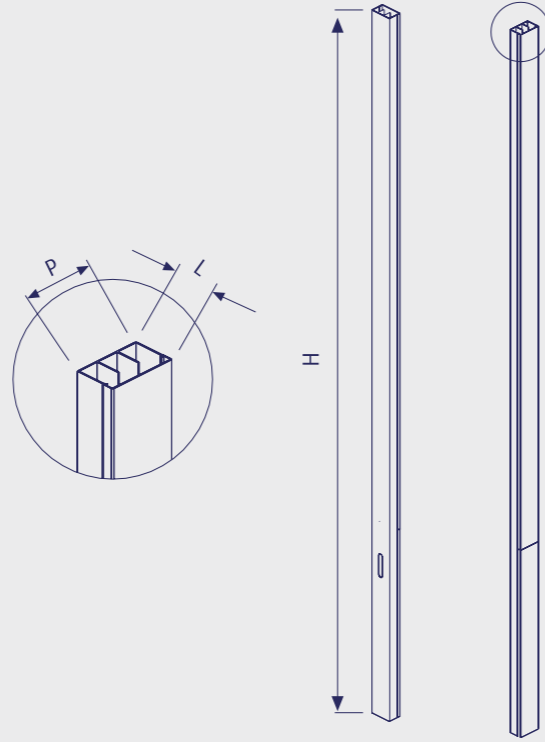

Code / Kod	P	H	L	Description / Açıklama
18X0000002	90	3200	55	
18X0000003	90	3500	55	

FLASHING IDENTIFICATION LAMP - WITH LED
NUMARATÖR LAMBA LED IŞIKLI

Code / Kod	P	H	L	Description / Açıklama
97000000137	290	200		

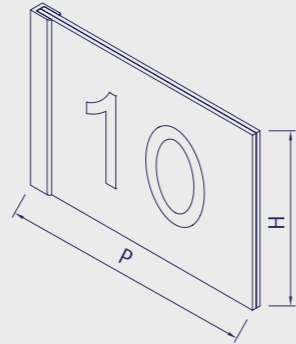

KEYBOARD HOLDER & SCANNER PROTECTION PLEXY
ÇİFT KATLI SCANNER KORUYUCU PLEKSİ

Code / Kod	P	H	L	Description / Açıklama
93000000570	175	465	425	Thickness / Kalınlık: 6 mm

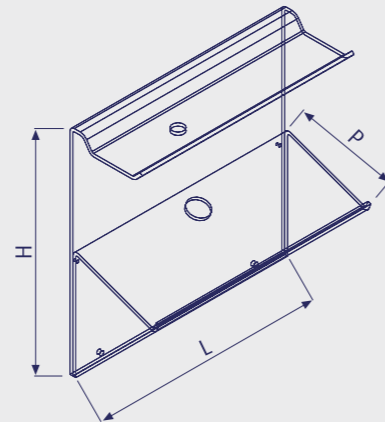

CHECK-OUT
KASAALTI

CHECK-OUT CLOSURE
KASA ALTI KORİDOR KAPISI

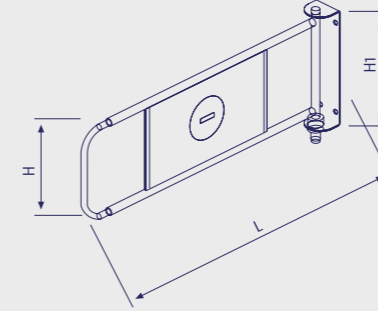

Code / Kod	P	H	L	Description / Açıklama
18X0000005U	210	250	640	Length is adjustable up to 840 mm 840 mm'ye kadar uzatılabilir.

NYLON BAG CARRIER
POŞET ARABASI

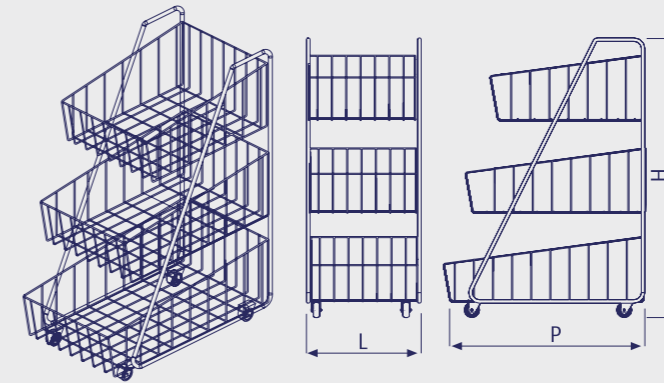

Code / Kod	P	H	L	Description / Açıklama
18X0000010B	680	600	375	Thickness : 6 mm / Kalınlık : 6 mm



CHECK-OUT
KASAALTI

NEXT CUSTOMER BAR
BİR SONRAKİ MÜŞTERİ AYRACI



Code / Kod	P	H	L	Description / Açıklama
93000000087	240	240	350	Wooden / Ahşap
93000000629	250	250	350	Aluminum / Alüminyum

CASHIER CHAIR
KASİYER SANDALYESİ



Code / Kod	P	H	L	Description / Açıklama
97000000075				RED / BLACK / ORANGE

MULTI FUNCTIONAL POST HOLDER
ÇOKLU POS APARATI

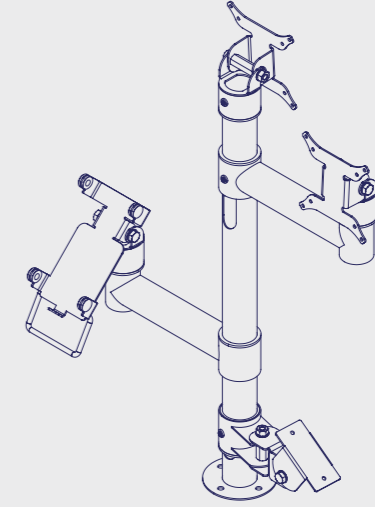
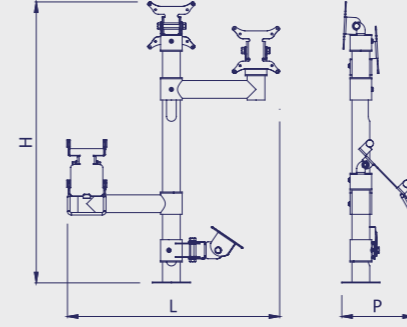

Code / Kod	P	H	L	Description / Açıklama
18X0000043	170	653	500	



CHECK-OUT
KASAALTI

WOODEN DRAWER FOR CHECK-OUT
AHŞAP KASAALTI ÇEKMECESİ

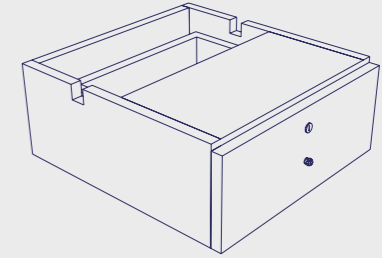
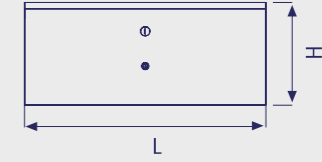

Code / Kod	P	H	L	Description / Açıklama
18X0000020M	395	155	370	

FLIP - LID CASH DRAWER
PARA KUTUSU

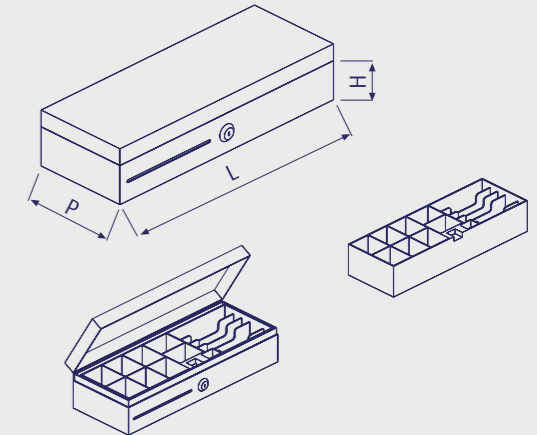

Code / Kod	P	H	L	Description / Açıklama
97000000064	170	120	460	



ACCESSORIES

AKSESUAR



ACCESSORIES
AKSESUAR

FRONT GRILL H: 40 mm
ÖN TEL H: 40 mm

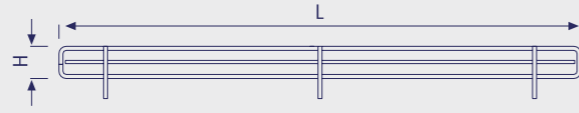

Code / Kod	P	H	L	Description / Açıklama
11A000002N		40	500	Chrome coated / Nikel kaplama
11A000004N		40	700	Zinc coated / Çinko kaplama
11A000006N		40	900	Painted / Boyalı
11A000007N		40	1000	
11A000008N		40	1250	
11A000009N		40	1330	

FRONT GRILL H: 80 mm
ÖN TEL H: 0 mm

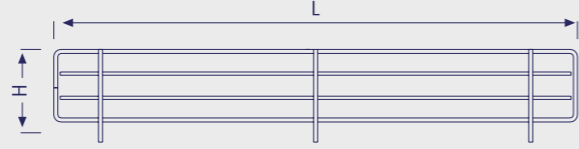

Code / Kod	P	H	L	Description / Açıklama
11A0000011N		80	500	Chrome coated / Nikel kaplama
11A0000013N		80	700	Zinc coated / Çinko kaplama
11A0000015N		80	900	Painted / Boyalı
11A0000016N		80	1000	
11A0000017N		80	1250	
11A0000018N		80	1330	

FRONT GRILL FOR WIRE SHELF H: 40 mm
TEL RAFA GÖRE ÖN TEL H: 40 mm

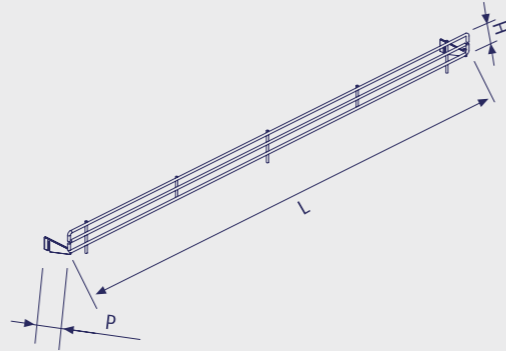

Code / Kod	P	H	L	Description / Açıklama
11A0000019N	70	40	500	Chrome coated / Nikel kaplama
11A0000021N	70	40	700	Zinc coated / Çinko kaplama
11A0000023N	70	40	900	Painted / Boyalı
11A0000024N	70	40	1000	
11A0000025N	70	40	1250	

FRONT GRILL FOR WIRE SHELF H: 80 mm
TEL RAFA GÖRE ÖN TEL H: 0 mm

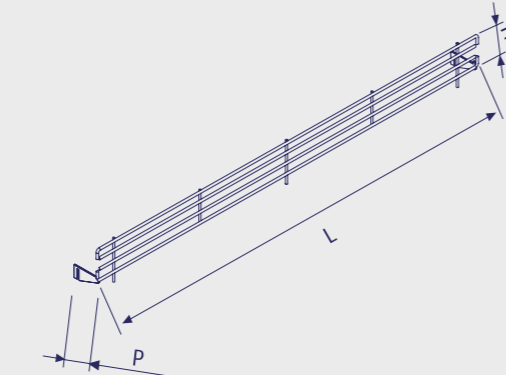

Code / Kod	P	H	L	Description / Açıklama
11A0000026N	70	80	500	Chrome coated / Nikel kaplama
11A0000028N	70	80	700	Zinc coated / Çinko kaplama
11A0000030N	70	80	900	Painted / Boyalı
11A0000031N	70	80	1000	
11A0000032N	70	80	1250	



ACCESSORIES
AKSESUAR

FRONT GRILL INTERNAL CORNER H: 40 mm
İÇ KÖŞE ÖN TEL H: 40 mm

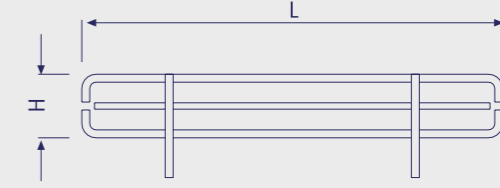

Code / Kod	P	H	L	Description / Açıklama
11A0000033N	300	40	400	Chrome coated / Nikel kaplama
11A0000034N	400	40	270	Zinc coated / Çinko kaplama
11A0000035N	500	40	125	Painted / Boyalı

FRONT GRILL INTERNAL CORNER H: 80 mm
İÇ KÖŞE ÖN TEL H: 0 mm

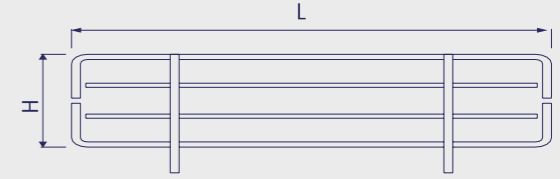

Code / Kod	P	H	L	Description / Açıklama
11A0000036N	300	80	400	Chrome coated / Nikel kaplama
11A0000037N	400	80	270	Zinc coated / Çinko kaplama
11A0000038N	500	80	125	Painted / Boyalı

FRONT GRILL EXTERNAL CORNER H: 40 mm
DIŞ KÖŞE ÖN TEL H: 40 mm

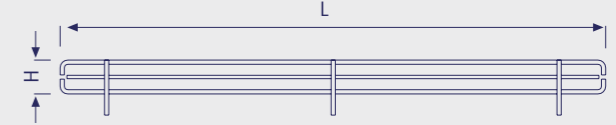

Code / Kod	P	H	L	Description / Açıklama
11A0000039N	300	40		Chrome coated / Nikel kaplama
11A0000040N	400	40		Zinc coated / Çinko kaplama
11A0000041N	500	40		Painted / Boyalı
11A0000042N	600	40		

FRONT GRILL EXTERNAL CORNER H: 80 mm
DIŞ KÖŞE ÖN TEL H: 0 mm

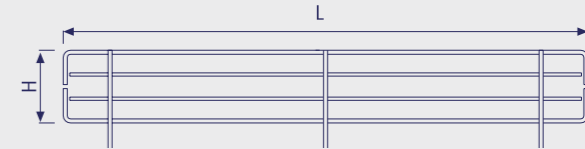

Code / Kod	P	H	L	Description / Açıklama
11A0000043N	300	80		Chrome coated / Nikel kaplama
11A0000044N	400	80		Zinc coated / Çinko kaplama
11A0000045N	500	80		Painted / Boyalı
11A0000046N	600	80		



ACCESSORIES
AKSESUAR

ZIG-ZAG FRONT GRILL H: 40 mm
ZİG-ZAG ÖN TEL H: 40 mm

Code / Kod	P	H	L	Description / Açıklama
11A0000053N		40	500	Chrome coated / Nikel kaplama
11A0000055N		40	700	Zinc coated / Çinko kaplama
11A0000057N		40	900	Painted / Boyalı
11A0000058N		40	1000	
11A0000059N		40	1250	
11A0000060N		40	1330	

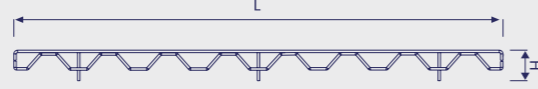

ZIG-ZAG ROUNDED FRONT GRILL H: 40 mm
ZİG-ZAG OVAL ÖN TEL H: 40 mm

Code / Kod	P	H	L	Description / Açıklama
11A0000122N	300	40		Chrome coated / Nikel kaplama
11A0000123N	400	40		Zinc coated / Çinko kaplama
11A0000124N	500	40		Painted / Boyalı
11A0000125N	600	40		

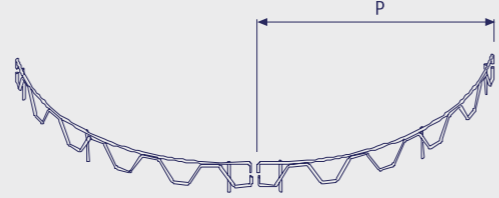

ROUNDED FRONT GRILL H: 40 mm
OVAL ÖN TEL H: 40 mm

Code / Kod	P	H	L	Description / Açıklama
11A0000069N	300	40		Chrome coated / Nikel kaplama
11A0000070N	400	40		Zinc coated / Çinko kaplama
11A0000071N	500	40		30x60 Dikme için
11A0000072N	600	40		Painted / Boyalı
11A0000073N	300	40		Chrome coated / Nikel kaplama
11A0000074N	400	40		Zinc coated / Çinko kaplama
11A0000075N	500	40		30x80 Dikme için
11A0000076N	600	40		Painted / Boyalı

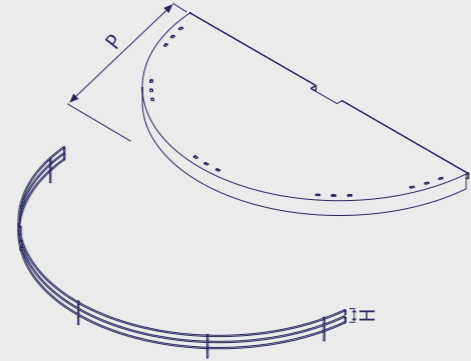

ROUNDED FRONT GRILL H: 80 mm
OVAL ÖN TEL H: 80 mm

Code / Kod	P	H	L	Description / Açıklama
11A0000077N	300	80		Chrome coated / Nikel kaplama
11A0000078N	400	80		Zinc coated / Çinko kaplama
11A0000079N	500	80		30x60 Dikme için
11A0000080N	600	80		Painted / Boyalı
11A0000081N	300	80		Chrome coated / Nikel kaplama
11A0000082N	400	80		Zinc coated / Çinko kaplama
11A0000083N	500	80		30x80 Dikme için
11A0000084N	600	80		Painted / Boyalı

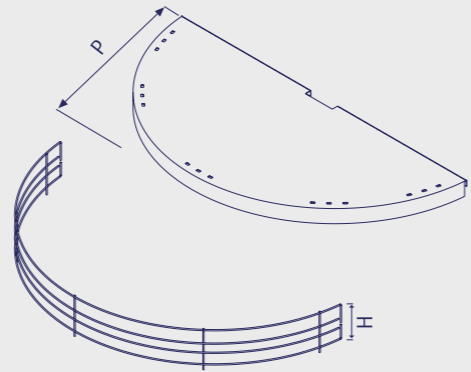

FRONT PLEXY
4 mm ÖN PLEKSİ

Code / Kod	P	H	L	Description / Açıklama
92000003720		40	500	Transparent / Şeffaf
92000003721		40	600	
92000003722		40	700	Thickness 4 mm / Kalınlık 4mm
92000003723		40	800	
92000003724		40	900	To be used together with plexy holder
92000003725		40	1000	Pleksi tutucu ile kullanılır.
92000003726		40	1250	
92000003727		40	1330	
92000003728		80	500	
92000003729		80	600	
92000003730		80	700	
92000003731		80	800	
92000003732		80	900	
92000003733		80	1000	
92000003734		80	1250	
92000003735		80	1330	

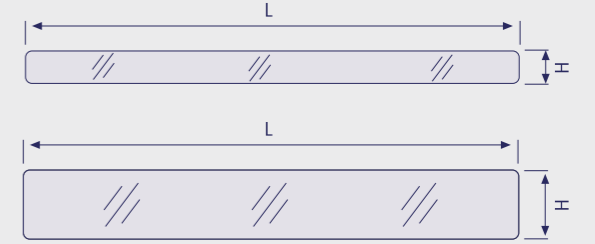

SEPARATION PLEXY
4 mm YAN PLEKSİ

Code / Kod	P	H	L	Description / Açıklama
92000003736		40	200	Transparent / Şeffaf
92000003737		40	300	Thickness 4 mm / Kalınlık 4 mm
92000003738		40	400	
92000003739		40	500	To be used together with plexy holder
92000003740		40	600	Pleksi tutucu ile kullanılır.
92000003741		80	200	
92000003742		80	300	
92000003743		80	400	
92000003744		80	500	
92000003745		80	600	

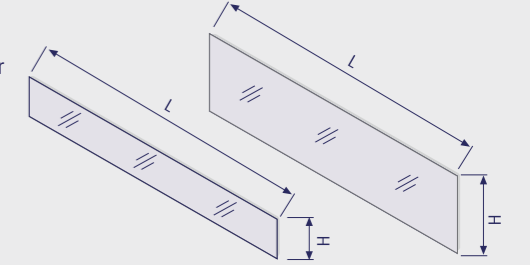

PLEXY HOLDER
PLEKSİ ÖN TEL ARA TEL TUTUCU

Code / Kod	P	H	L	Description / Açıklama
93000000021		20	25	Transparent / Şeffaf

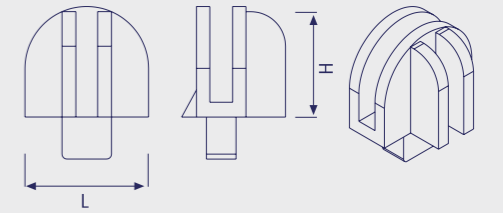

SEPARATION GRILL H: 40 mm / H: 80 mm
ARA TEL H: 40 mm / H: 80 mm

Code / Kod	P	H	L	Description / Açıklama
11B0000001N	300	40		Chrome coated / Nikel kaplama
11B0000002N	400	40		Zinc coated / Çinko kaplama
11B0000003N	500	40		Painted / Boyalı
11B0000004N	600	40		
11B0000005N	700	40		
11B0000006N	300	80		
11B0000007N	400	80		
11B0000008N	500	80		
11B0000009N	600	80		
11B0000010N	700	80		

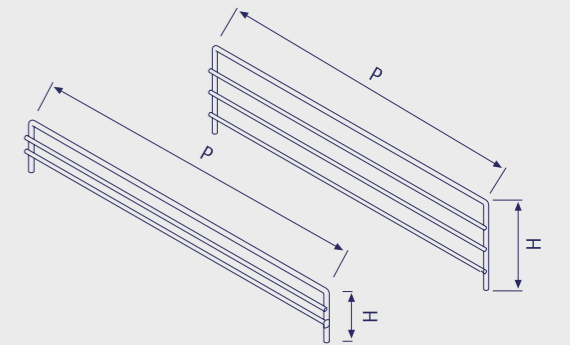

ACCESSORIES
AKSESUAR



ACCESSORIES
AKSESUAR

STICKABLE RAIL FOR SEPARATION PLEXY ARA PLEKSİ İÇİN YAPIŞKANLI RAY

Code / Kod	P	H	L	Description / Açıklama
9300000813			500	Stickable / Yapışkanlı
9300000814			700	
9300000815			900	
9300000816			1000	
9300000817			1250	
9300000818			1330	

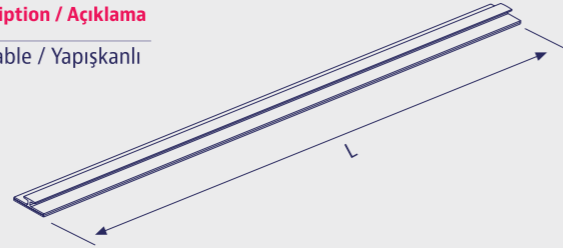

PUSH MECHANISM ÜRÜN İTİCİ MEKANİZMA

Code / Kod	P	H	L	Description / Açıklama
9300000819	435			

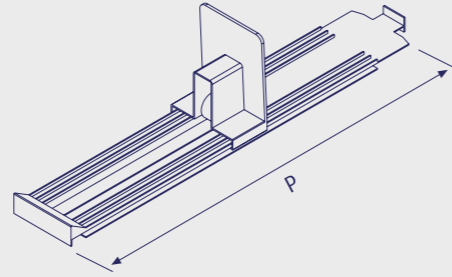

SEPARATION PLEXY ARA PLEKSİ

Code / Kod	P	H	L	Description / Açıklama
9300000820	535	60		Sağ
9300000821				Sol
9300000822				Orta
				Adjustable for each 25 mm 25 mm de bir kırılabilir. Left / Middle / Right Sol / Orta / Sağ

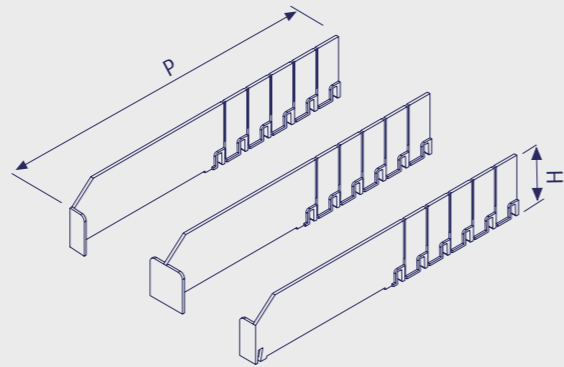

SEPARATION PLEXY ARA PLEKSİ

Code / Kod	P	H	L	Description / Açıklama
9300000823	535	120		Sağ
9300000824				Sol
9300000825				Orta
				Adjustable for each 25 mm 25 mm de bir kırılabilir. Left / Middle / Right Sol / Orta / Sağ

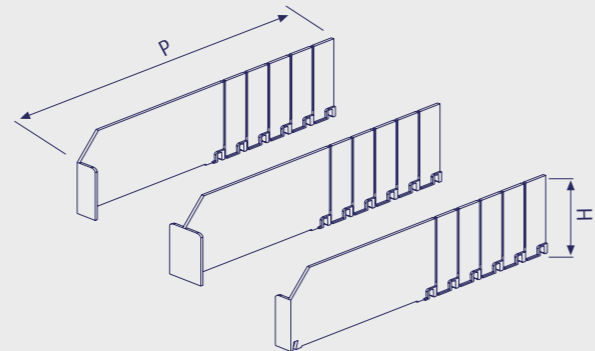

SEPERATION GRILL H: 40/120 mm YAN TEL H: 40-120 mm

Code / Kod	P	H	H1	Description / Açıklama
11B000011N	300	120	40	Chrome coated / Nikel kaplama
11B000012N	400	120	40	Zinc coated / Çinko kaplama
11B000013N	500	120	40	Painted / Boyalı
11B000014N	600	120	40	

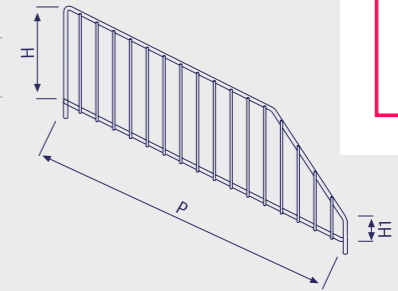

ACCESSORIES
AKSESUAR

SEPERATION GRILL H: 80/120 mm YAN TEL H: 0-120 mm

Code / Kod	P	H	H1	Description / Açıklama
11B000015N	300	120	80	Chrome coated / Nikel kaplama
11B000016N	400	120	80	Zinc coated / Çinko kaplama
11B000017N	500	120	80	Painted / Boyalı
11B000018N	600	120	80	

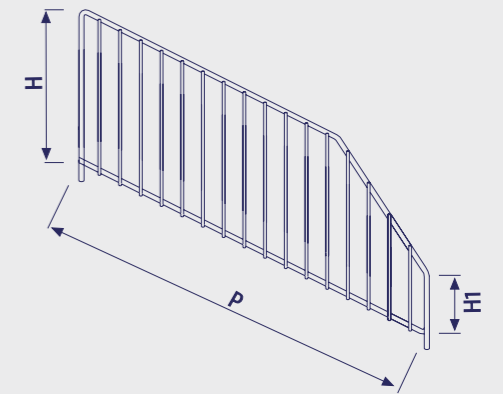

WIRE HOOK FOR PERFORATED BACK PANEL DELİKLİ SACA GEÇME DÜZ SPOT TEL

Code / Kod	P	H	L	Description / Açıklama
11C000001N	100			Chrome coated / Nikel kaplama
11C000002N	150			Zinc coated / Çinko kaplama
11C000003N	200			Painted / Boyalı
11C000004N	250			
11C000005N	300			
11C000006N	350			
11C000007N	400			

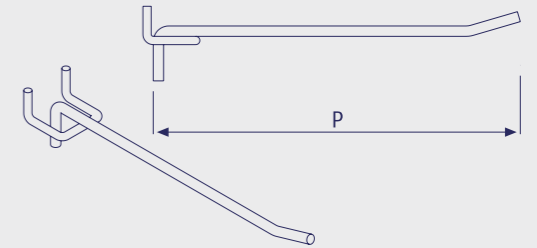

WIRE HOOK FOR PERFORATED BACK PANEL WITH LABEL HOLDER DELİKLİ SACA GEÇME ETİKETLİ SPOT TEL

Code / Kod	P	H	L	Description / Açıklama
11C000009N	150			Chrome coated / Nikel kaplama
11C000010N	200			Zinc coated / Çinko kaplama
11C000011N	250			Painted / Boyalı
11C000012N	300			
11C000013N	350			
11C000014N	400			

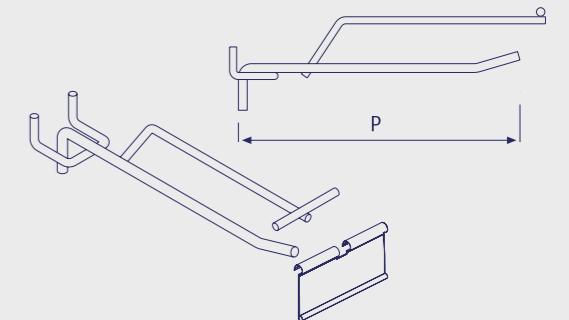



ACCESSORIES
AKSESUAR

DUAL WIRE HOOK FOR PERFORATED BACK PANEL DELİKLİ SACA GEÇME U SPOT TEL

Code / Kod	P	H	L	Description / Açıklama
11C0000015N	150			Chrome coated / Nikel kaplama
11C0000016N	200			Zinc coated / Çinko kaplama
11C0000017N	250			Painted / Boyalı
11C0000018N	300			
11C0000019N	350			
11C0000020N	400			

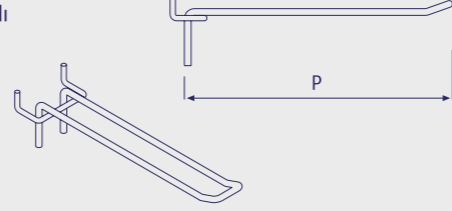

DUAL WIRE HOOK FOR PERFORATED BACK PANEL WITH LABEL HOLDER DELİKLİ SACA GEÇME ETİKETLİ U SPOT TEL

Code / Kod	P	H	L	Description / Açıklama
11C0000021N	150			Chrome coated / Nikel kaplama
11C0000022N	200			Zinc coated / Çinko kaplama
11C0000023N	250			Painted / Boyalı
11C0000024N	300			
11C0000025N	350			
11C0000026N	400			

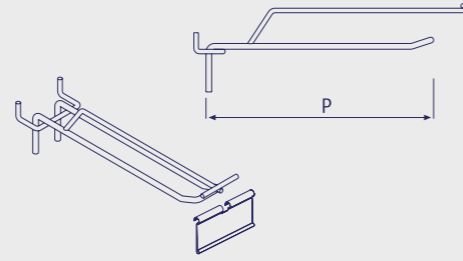

LABEL HOLDER FOR WIRE HOOK SPOT TEL ETİKETLİĞİ

Code / Kod	P	H	L	Description / Açıklama
92000003505		39	50	
92000003506		39	60	
92000003507		39	80	
92000003508		39	90	
92000003509		39	100	

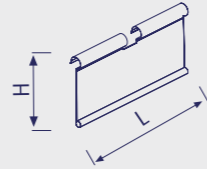

REAR BAR ASKI TUTUCU

Code / Kod	P	H	L	Description / Açıklama
11I0000001N			500	Chrome coated / Nikel kaplama
11I0000002N			600	Zinc coated / Çinko kaplama
11I0000003N			700	Painted / Boyalı
11I0000005N			900	
11I0000006N			1000	
11I0000007N			1250	
11I0000008N			1330	

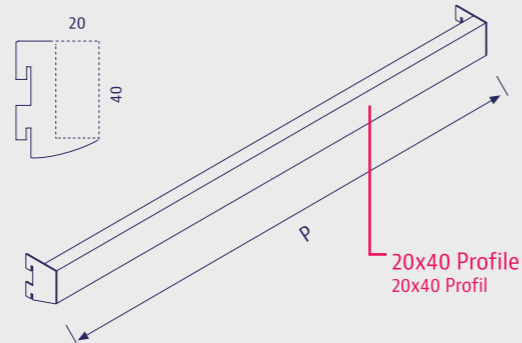

WIRE HOOK FOR REAR BAR ASKI TUTUCUYA GEÇME DÜZ SPOT TEL

Code / Kod	P	H	L	Description / Açıklama
11C0000027N	100			Chrome coated / Nikel kaplama
11C0000028N	150			Zinc coated / Çinko kaplama
11C0000029N	200			Painted / Boyalı
11C0000030N	250			
11C0000031N	300			
11C0000032N	350			
11C0000033N	400			

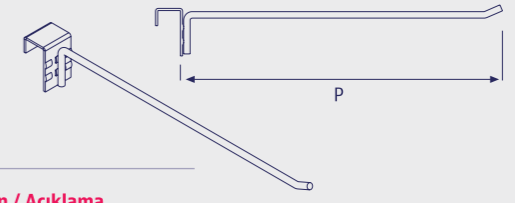

WIRE HOOK FOR REAR BAR WITH LABEL HOLDER ASKI TUTUCUYA GEÇME ETİKETLİ SPOT TEL

Code / Kod	P	H	L	Description / Açıklama
11C0000035N	150			Chrome coated / Nikel kaplama
11C0000036N	200			Zinc coated / Çinko kaplama
11C0000037N	250			Painted / Boyalı
11C0000038N	300			
11C0000039N	350			
11C0000040N	400			

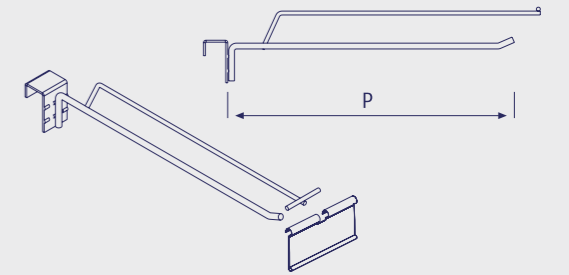

DUAL WIRE HOOK FOR REAR BAR ASKI TUTUCUYA GEÇME U SPOT TEL

Code / Kod	P	H	L	Description / Açıklama
11C0000041N	150			Chrome coated / Nikel kaplama
11C0000042N	200			Zinc coated / Çinko kaplama
11C0000043N	250			Painted / Boyalı
11C0000044N	300			
11C0000045N	350			
11C0000046N	400			

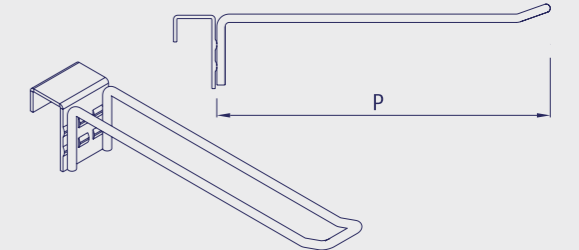

DUAL WIRE HOOK FOR REAR BAR WITH LABEL HOLDER ASKI TUTUCUYA GEÇME ETİKETLİ U SPOT TEL

Code / Kod	P	H	L	Description / Açıklama
11C0000047N	150			Chrome coated / Nikel kaplama
11C0000048N	200			Zinc coated / Çinko kaplama
11C0000049N	250			Painted / Boyalı
11C0000050N	300			
11C0000051N	350			
11C0000052N	400			

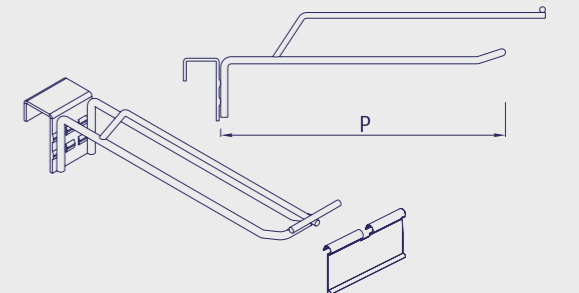

ACCESSORIES
AKSESUAR



ACCESSORIES
AKSESUAR

**VACUUM CLEANER
HOLDER FOR REAR BAR**
ASKI TUTUCUYA GEÇME
ELEKTRİK SÜPÜRGESİ
TUTUCU

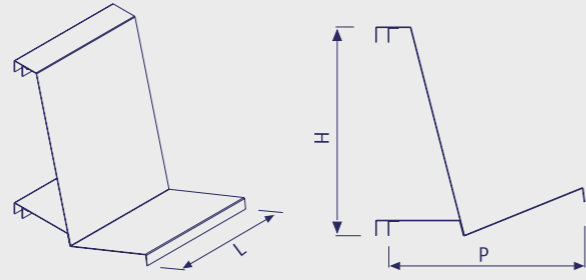

Code / Kod	P	H	L	Description / Açıklama
11E0000012B	420	400	300	Will be used with 2 rear bar
11E0000012N	420	400	300	2 askı tutucu ile kullanılır.

HOSE HOLDER FOR REAR BAR
ASKI TUTUCUYA GEÇME HORTUM TUTUCU

Code / Kod	P	H	L	Description / Açıklama
11E0000013B	121	190	320	Chrome coated / Nikel kaplama
11E0000013N	121	190	320	Zinc coated / Çinko kaplama Painted / Boyalı

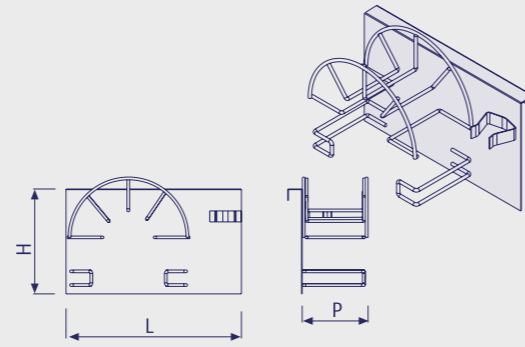

INCLINE HOOK ON HOLDER FOR REAR BAR
ASKI TUTUCUYA GEÇME EĞİMLİ BONCUKLU ASKI

Code / Kod	P	H	L	Description / Açıklama
11D0000007N	300			Chrome coated / Nikel kaplama
11D0000008N	400			Zinc coated / Çinko kaplama
11D0000009N	500			Painted / Boyalı

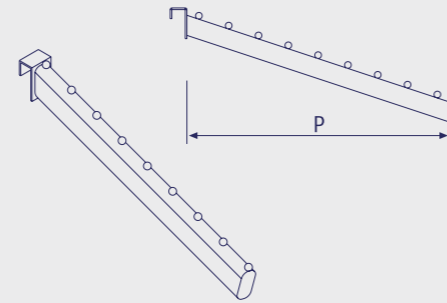

BALL HOLDER FOR REAR BAR
ASKI TUTUCUYA GEÇME TOP TUTUCU

Code / Kod	P	H	L	Description / Açıklama
11E0000001N	145	486	180	for 2 ball s / 2 Top için
11E0000002N	145	645	180	for 3 ball s / 3 Top için
				Chrome coated / Nikel kaplama
				Zinc coated / Çinko kaplama
				Painted / Boyalı

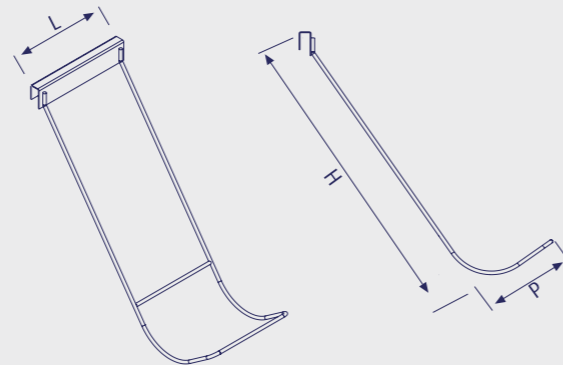

**INCLINE WIRE HOOK
FOR REAR BAR**
ASKI TUTUCUYA GEÇME
EĞİMLİ BONCUKLU TEL

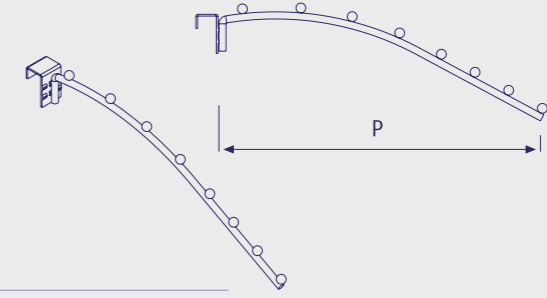

Code / Kod	P	H	L	Description / Açıklama
11D0000001N	200			Chrome coated / Nikel kaplama
11D0000002N	300			Zinc coated / Çinko kaplama
11D0000003N	400			Painted / Boyalı

HOOK ON HOLDER FOR REAR BAR
ASKI TUTUCUYA GEÇME TEK BONCUKLU DÜZ ASKI

Code / Kod	P	H	L	Description / Açıklama
11D0000004N	300			Chrome coated / Nikel kaplama
11D0000005N	400			Zinc coated / Çinko kaplama
11D0000006N	500			Painted / Boyalı

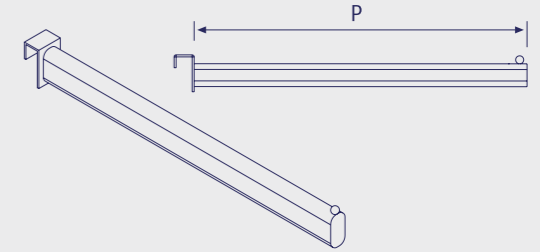

PLATE HOLDER FOR REAR BAR
RAF ÜSTÜ TEL TABAKLIK

Code / Kod	P	H	L	Description / Açıklama
11E0000003N	300			Chrome coated / Nikel kaplama
11E0000004N	400			Zinc coated / Çinko kaplama
				Painted / Boyalı

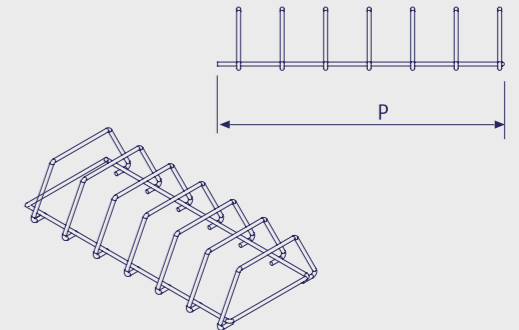
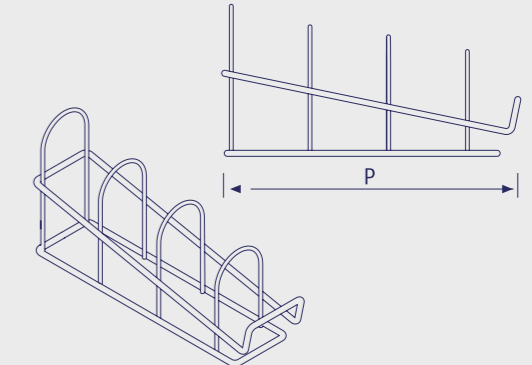

PLATE HOLDER FOR SHELF
RAF ÜSTÜ OVAL TEL TABAKLIK

Code / Kod	P	H	L	Description / Açıklama
11E0000005N	300			Chrome coated / Nikel kaplama
11E0000006N	400			Zinc coated / Çinko kaplama
				Painted / Boyalı



ACCESSORIES
AKSESUAR



ACCESSORIES
AKSESUAR

WOODEN PLATE HOLDER FOR SHELF
AHŞAP TABAKLIK

Code / Kod	P	H	L	Description / Açıklama
97000000083	400			Wooden / Ahşap

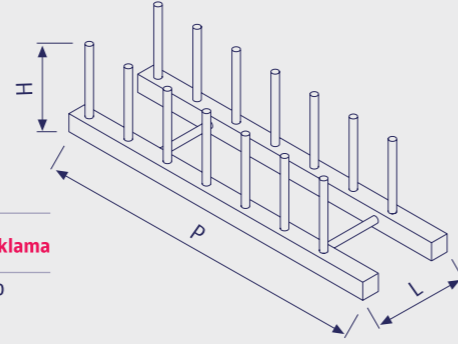

IRON HOLDER FOR REAR BAR
ASKI TUTUCUYA GEÇME ÜTÜ TUTUCU

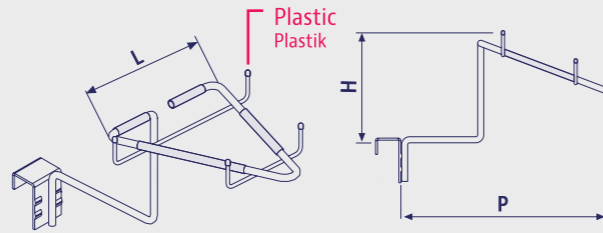

Code / Kod	P	H	L	Description / Açıklama
11E0000009N	210	105	130	Chrome coated / Nikel kaplama Zinc coated / Çinko kaplama Painted / Boyalı

HAIR DRYER HOLDER FOR REAR BAR
ASKI TUTUCUYA GEÇME FÖN MAKİNASI TUTUCU

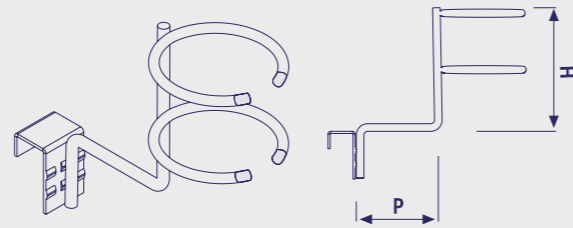

Code / Kod	P	H	L	Description / Açıklama
11E0000010N	160	115		Chrome coated / Nikel kaplama Zinc coated / Çinko kaplama Painted / Boyalı

HAIR CURLER HOLDER FOR REAR BAR
ASKI TUTUCUYA GEÇME SAC ŞEKİLENDİRİCİ TUTUCU

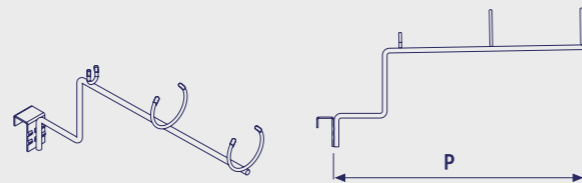

Code / Kod	P	H	L	Description / Açıklama
11E0000011N	390			Chrome coated / Nikel kaplama Zinc coated / Çinko kaplama Painted / Boyalı



ACCESSORIES
AKSESUAR

WIRE HOOK FOR WIRE BACK PANEL
TEL ARKA PANOYA GEÇME SPOT TEL

Code / Kod	P	H	L	Description / Açıklama
11C0000053N	100			Chrome coated / Nikel kaplama
11C0000054N	150			Zinc coated / Çinko kaplama
11C0000055N	200			Painted / Boyalı
11C0000056N	250			
11C0000057N	300			
11C0000058N	350			
11C0000059N	400			

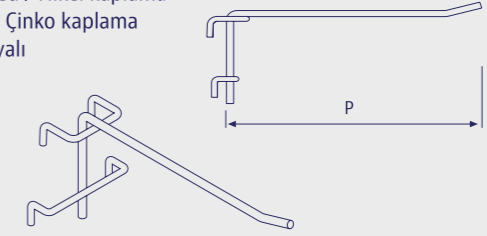

WIRE HOOK FOR WIRE BACK PANEL WITH LABEL HOLDER
TEL ARKA PANOYA GEÇME ETİKETLİ SPOT TEL

Code / Kod	P	H	L	Description / Açıklama
11C0000060N	150			Chrome coated / Nikel kaplama
11C0000061N	200			Zinc coated / Çinko kaplama
11C0000062N	250			Painted / Boyalı
11C0000063N	300			
11C0000064N	350			
11C0000065N	400			

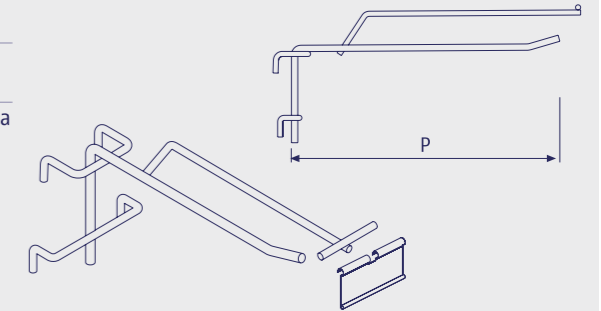

DUAL WIRE HOOK FOR WIRE BACK PANEL
TEL ARKA PANOYA GEÇME U SPOT TEL

Code / Kod	P	H	L	Description / Açıklama
11C0000066N	100			Chrome coated / Nikel kaplama
11C0000067N	150			Zinc coated / Çinko kaplama
11C0000068N	200			Painted / Boyalı
11C0000069N	250			
11C0000070N	300			
11C0000071N	350			
11C0000072N	400			

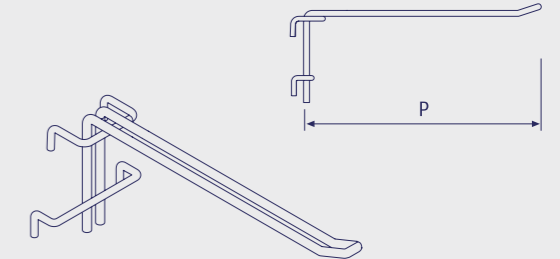

DUAL WIRE HOOK FOR WIRE BACK PANEL WITH LABEL HOLDER
TEL ARKA PANOYA GEÇME ETİKETLİ U SPOT TEL

Code / Kod	P	H	L	Description / Açıklama
11C0000073N	150			Chrome coated / Nikel kaplama
11C0000074N	200			Zinc coated / Çinko kaplama
11C0000075N	250			Painted / Boyalı
11C0000076N	300			
11C0000077N	350			
11C0000078N	400			

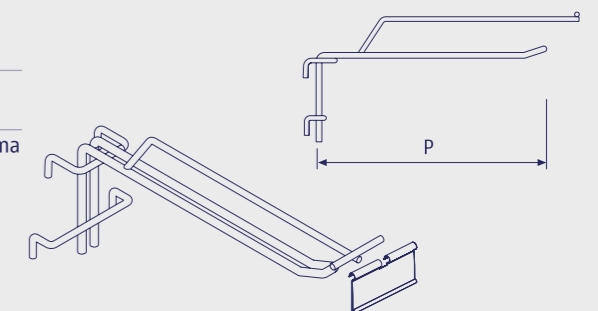



ACCESSORIES
AKSESUAR

RACKET HOLDER FOR REAR BAR
ASKI TUTUCUYA GEÇME RAKET TUTUCU

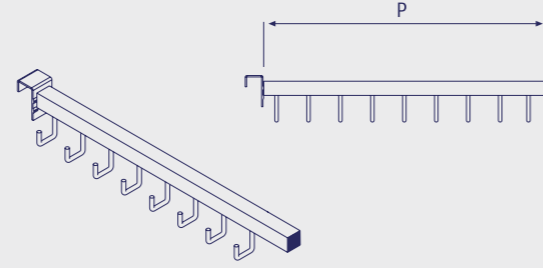

Code / Kod	P	H	L	Description / Açıklama
11E0000014N	400			Chrome coated / Nikel kaplama Zinc coated / Çinko kaplama Painted / Boyalı

BROOM HOLDER FOR REAR BAR
ASKI TUTUCUYA GEÇME SÜPÜRGE TUTUCU

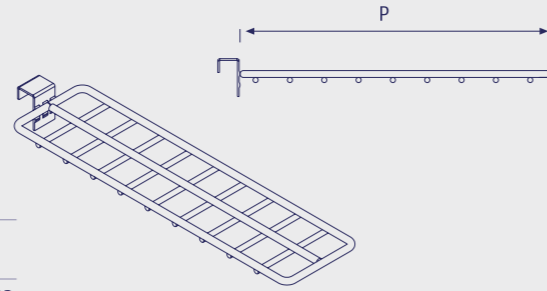

Code / Kod	P	H	L	Description / Açıklama
11E0000015N	400			Chrome coated / Nikel kaplama Zinc coated / Çinko kaplama Painted / Boyalı

FLOWER CONE HOLDER / PLASTIC FLOWER CONE
ASKI TUTUCUYA GEÇME VAZO TUTUCU / PLASTİK VAZO

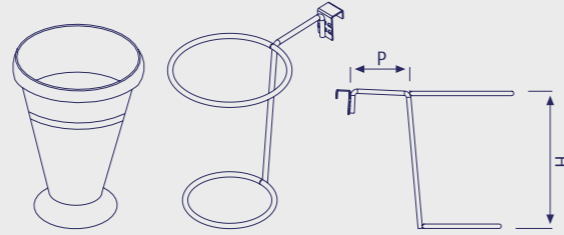

Code / Kod	P	H	L	Description / Açıklama
11E0000016N	120	250		Chrome coated / Nikel kaplama Zinc coated / Çinko kaplama
11E0000016B		250		Painted / Boyalı

CRICKET BAT
ASKI TUTUCUYA GEÇME KRİKET SOPASI TUTUCU

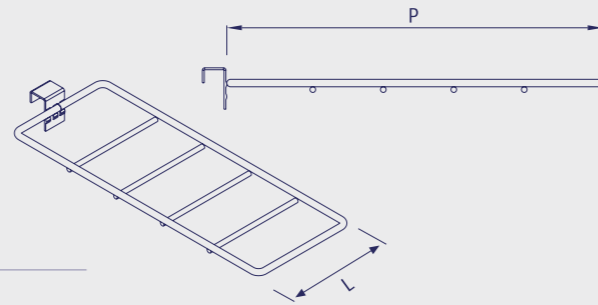

Code / Kod	P	H	L	Description / Açıklama
11E0000017N	450		151	Chrome coated / Nikel kaplama Zinc coated / Çinko kaplama Painted / Boyalı



ACCESSORIES
AKSESUAR

TRAY HOLDER FOR REAR BAR
ASKI TUTUCUYA GEÇME TEPŞİ TUTUCU

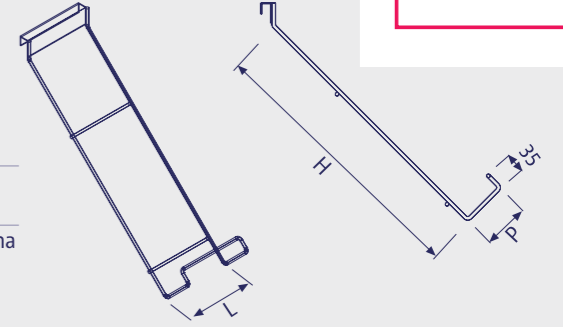

Code / Kod	P	H	L	Description / Açıklama
11E0000018N	100	600	180	Chrome coated / Nikel kaplama Zinc coated / Çinko kaplama Painted / Boyalı

PILLOW SEPARATOR
YASTIK SEPERATÖRÜ

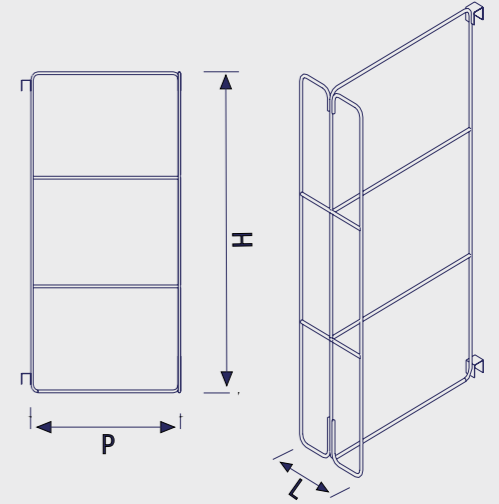

Code / Kod	P	H	L	Description / Açıklama
11E0000019N	500	1800	200	Chrome coated / Nikel kaplama Zinc coated / Çinko kaplama Will be used with 2 rear bar 2 askı tutucu ile kullanılır. Painted / Boyalı

"U" SHAPE HOLDER
U ASKI

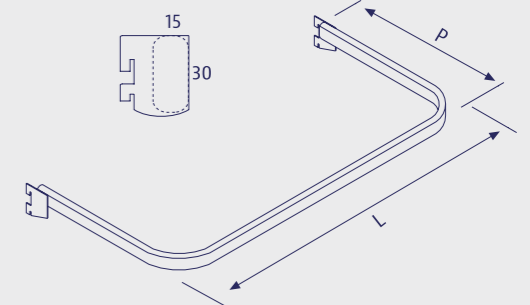

Code / Kod	P	H	L	Description / Açıklama
11D0000020N	300		500	Chrome coated / Nikel kaplama
11D0000027N	300		600	Zinc coated / Çinko kaplama
11D0000021N	300		700	Painted / Boyalı
11D0000022N	300		900	
11D0000023N	300		1000	
11D0000024N	300		1250	



ACCESSORIES
AKSESUAR

WIRE BASKET SHELF PROFİLE GEÇME SEPET RAF

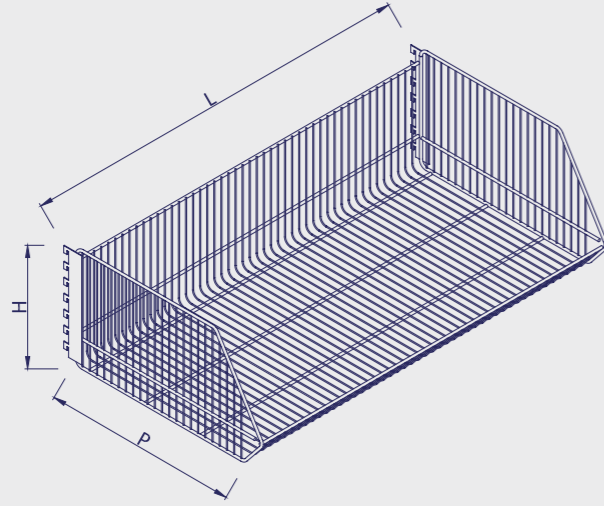

Code / Kod	P	H	L	Description / Açıklama
11F0000146N	400	300	900	Chrome coated / Nikel kaplama
11F0000117N	400	300	1000	Zinc coated / Çinko kaplama
11F0000118N	400	300	1250	Painted / Boyalı
11F0000141N	500	300	1250	
11F0000142N	600	300	1250	

BICYCLE STAND BİSİKLET STANDI

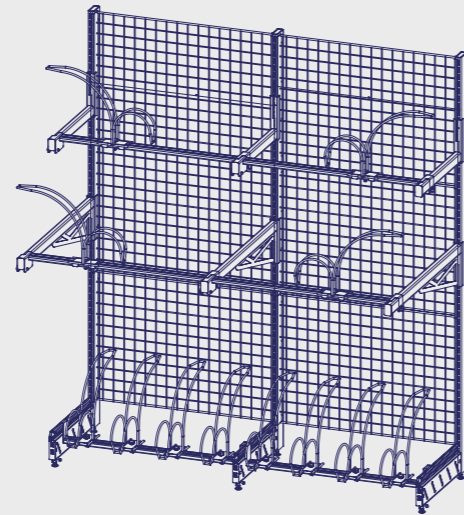
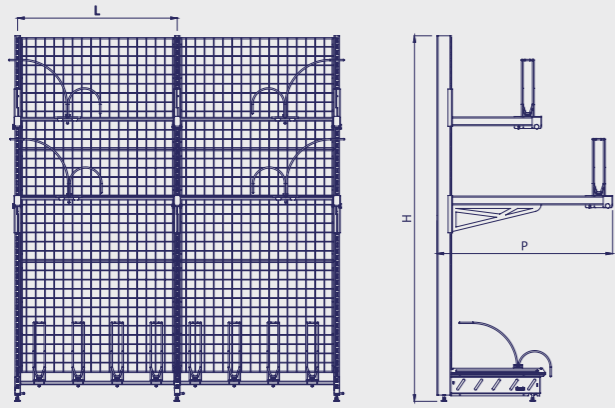

Code / Kod	P	H	L	Description / Açıklama
8100000002U	990	2060	900	



ACCESSORIES
AKSESUAR

WIRE BASKET SHELF PROFİLE GEÇME SEPET RAF

Code / Kod	P	H	L	Description / Açıklama
11F0000001N	300	170	500	Chrome coated / Nikel kaplama
11F0000002N	300	170	700	Zinc coated / Çinko kaplama
11F0000003N	300	170	900	Painted / Boyalı
11F0000004N	300	170	1000	* Basket with flat iron support
*11F0000005N	300	170	1250	* İşaretli ürünler Lama takviyeli olacaktır.
*11F0000006N	300	170	1330	
11F0000007N	400	170	500	
11F0000008N	400	170	700	
11F0000009N	400	170	900	
11F0000010N	400	170	1000	
*11F0000011N	400	170	1250	
*11F0000012N	400	170	1330	
11F0000013N	500	170	500	
11F0000014N	500	170	700	
11F0000015N	500	170	900	
11F0000016N	500	170	1000	
*11F0000017N	500	170	1250	
*11F0000018N	500	170	1330	
11F0000019N	600	170	500	
11F0000020N	600	170	700	
11F0000021N	600	170	900	
11F0000022N	600	170	1000	
*11F0000023N	600	170	1250	
*11F0000024N	600	170	1330	

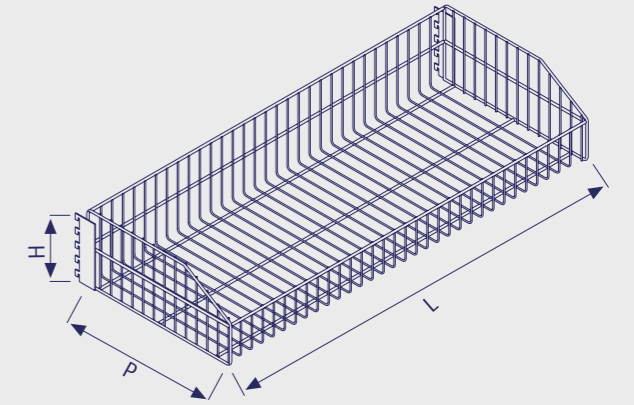

REINFORCED WIRE SHELF PROFİLE GEÇME TAKVİYELİ SEPET RAF

Code / Kod	P	H	L	Description / Açıklama
11F0000025N	300	230	500	Chrome coated / Nikel kaplama
11F0000026N	300	230	700	Zinc coated / Çinko kaplama
11F0000027N	300	230	900	Painted / Boyalı
11F0000028N	300	230	1000	* Basket with flat iron support
*11F0000029N	300	230	1250	* İşaretli ürünler Lama takviyeli olacaktır.
*11F0000030N	300	230	1330	
11F0000031N	400	230	500	
11F0000032N	400	230	700	
11F0000033N	400	230	900	
11F0000034N	400	230	1000	
*11F0000035N	400	230	1250	
*11F0000036N	400	230	1330	
11F0000037N	500	230	500	
11F0000038N	500	230	700	
11F0000039N	500	230	900	
11F0000040N	500	230	1000	
*11F0000041N	500	230	1250	
*11F0000042N	500	230	1330	
11F0000043N	600	230	500	
11F0000044N	600	230	700	
11F0000045N	600	230	900	
11F0000046N	600	230	1000	
*11F0000047N	600	230	1250	
*11F0000048N	600	230	1330	

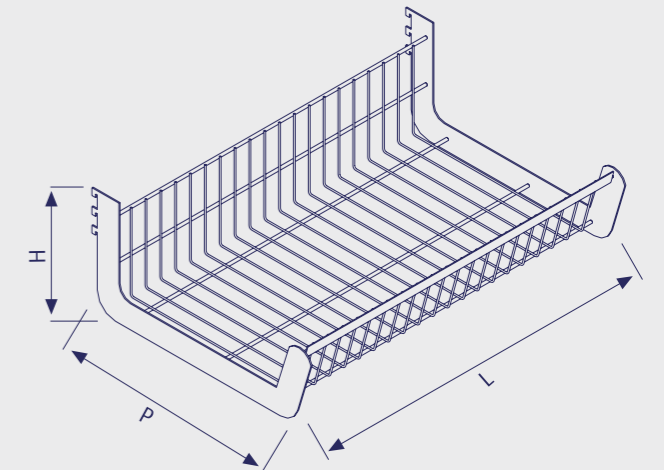



ACCESSORIES
AKSESUAR

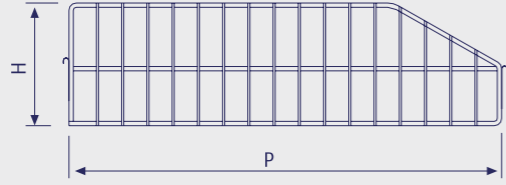

**WIRE SEPERATOR FOR
WIRE BASKET SHELF**
PROFİLE GEÇME SEPET RAF
ARA SEPERATÖRÜ

Code / Kod	P	H	L	Description / Açıklama
11F0000049N	300	170		Chrome coated / Nikel kaplama
11F0000050N	400	170		Zinc coated / Çinko kaplama
11F0000051N	500	170		Painted / Boyalı
11F0000052N	600	170		

WIRE SEPERATOR FOR REINFORCED WIRE SHELF
PROFİLE GEÇME TAKVİYELİ SEPET RAF SEPERATÖRÜ

Code / Kod	P	H	L	Description / Açıklama
11F0000053N	300	230		Chrome coated / Nikel kaplama
11F0000054N	400	230		Zinc coated / Çinko kaplama
11F0000055N	500	230		Painted / Boyalı
11F0000056N	600	230		

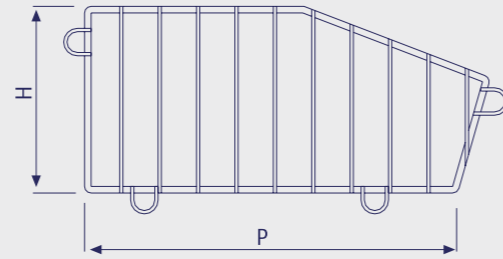

WIRE HOOK FOR SLATTED WOODEN PANEL
KANALLI AHŞAP PANOYA GEÇME DÜZ SPOT TEL

Code / Kod	P	H	L	Description / Açıklama
11C0000079N	150			Chrome coated / Nikel kaplama
11C0000080N	200			Zinc coated / Çinko kaplama
11C0000081N	250			Painted / Boyalı
11C0000082N	300			
11C0000083N	350			
11C0000084N	400			

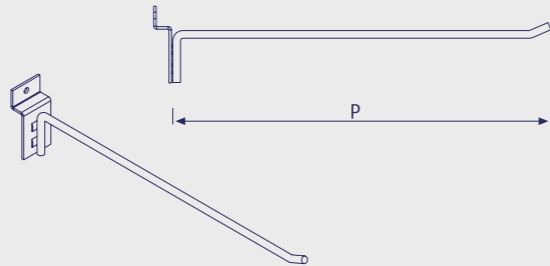

WIRE HOOK FOR SLATTED WOODEN PANEL WITH LABEL HOLDER
KANALLI AHŞAP PANOYA GEÇME ETİKETLİ SPOT TEL

Code / Kod	P	H	L	Description / Açıklama
11C0000085N	150			Chrome coated / Nikel kaplama
11C0000086N	200			Zinc coated / Çinko kaplama
11C0000087N	250			Painted / Boyalı
11C0000088N	300			
11C0000089N	350			
11C0000090N	400			

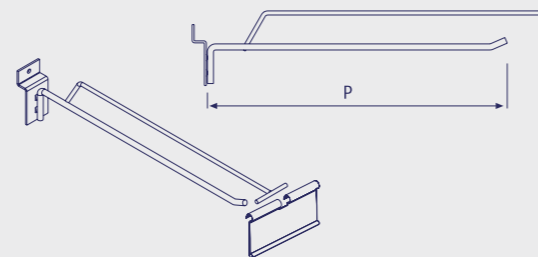

**DUAL WIRE HOOK FOR
SLATTED WOODEN PANEL**
KANALLI AHŞAP PANOYA GEÇME
U SPOT TEL

Code / Kod	P	H	L	Description / Açıklama
11C0000091N	150			Chrome coated / Nikel kaplama
11C0000092N	200			Zinc coated / Çinko kaplama
11C0000093N	250			Painted / Boyalı
11C0000094N	300			
11C0000095N	350			
11C0000096N	400			

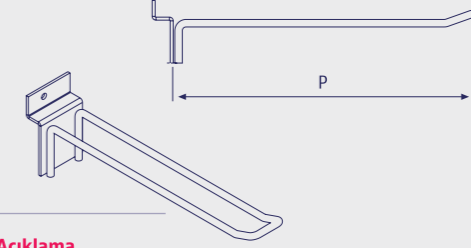

DUAL WIRE HOOK FOR SLATTED WOODEN PANEL WITH LABEL HOLDER
KANALLI AHŞAP PANOYA GEÇME ETİKETLİ U SPOT TEL

Code / Kod	P	H	L	Description / Açıklama
11C0000097N	150			Chrome coated / Nikel kaplama
11C0000098N	200			Zinc coated / Çinko kaplama
11C0000099N	250			Painted / Boyalı
11C0000100N	300			
11C0000101N	350			
11C0000102N	400			

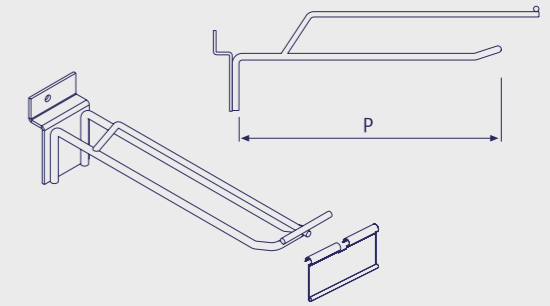

INCLINE WIRE HOOK FOR SLATTED WOODEN PANEL
KANALLI AHŞAP PANOYA GEÇME EĞİMLİ BONCUKLU SPOT TEL

Code / Kod	P	H	L	Description / Açıklama
11D0000010N	300			Chrome coated / Nikel kaplama
11D0000011N	350			Zinc coated / Çinko kaplama
11D0000012N	400			Painted / Boyalı

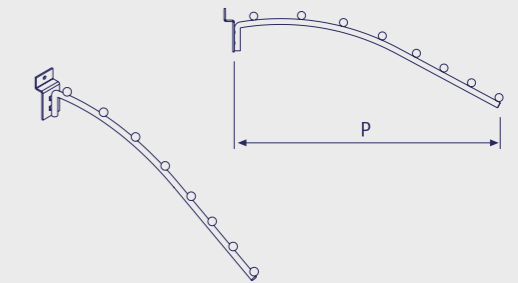

HOOK ON HOLDER FOR SLATTED WOODEN PANEL
KANALLI AHŞAP PANOYA GEÇME TEK BONCUKLU DÜZ ASKI

Code / Kod	P	H	L	Description / Açıklama
11D0000013N	300			Chrome coated / Nikel kaplama
11D0000014N	350			Zinc coated / Çinko kaplama
11D0000015N	400			Painted / Boyalı

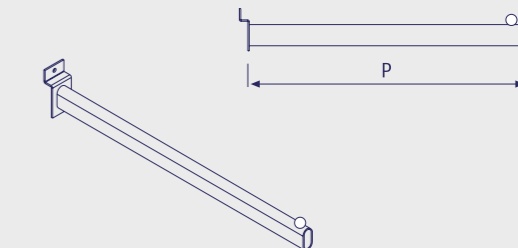

ACCESSORIES
AKSESUAR



ACCESSORIES
AKSESUAR

**INCLINED HOOK FOR
SLATTED WOODEN PANEL**
KANALLI AHŞAP PANOYA
GEÇME EĞİMLİ BONCUKLU ASKI

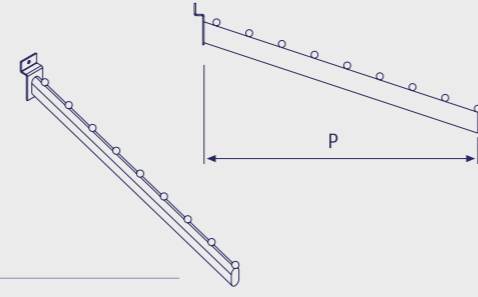

Code / Kod	P	H	L	Description / Açıklama
11D0000016N	300			Chrome coated / Nikel kaplama
11D0000017N	350			Zinc coated / Çinko kaplama
11D0000018N	400			Painted / Boyalı

BALL HOLDER FOR SLATTED WOODEN PANEL
KANALLI AHŞAP PANOYA GEÇME TOP TUTUCU

Code / Kod	P	H	L	Description / Açıklama
11E0000020N	150			Chrome coated / Nikel kaplama Zinc coated / Çinko kaplama Painted / Boyalı

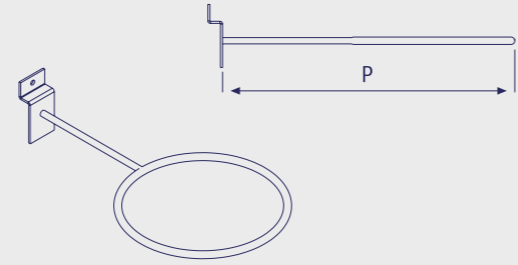

"U" SHAPE HOOK FOR SLATTED WOODEN PANEL
KANALLI AHŞAP PANOYA GEÇME U ASKI

Code / Kod	P	H	L	Description / Açıklama
11D0000028N	300		600	Chrome coated / Nikel kaplama
11D0000029N	300		900	Zinc coated / Çinko kaplama Painted / Boyalı

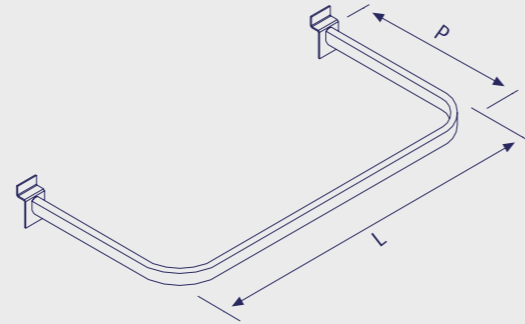

WIRE SHELF FOR SLATTED WOODEN PANEL
KANALLI AHŞAP PANOYA GEÇME TEL SEPET

Code / Kod	P	H	L	Description / Açıklama
11D0000033N	300	80	600	Chrome coated / Nikel kaplama
11D0000034N	300	80	900	Zinc coated / Çinko kaplama Painted / Boyalı

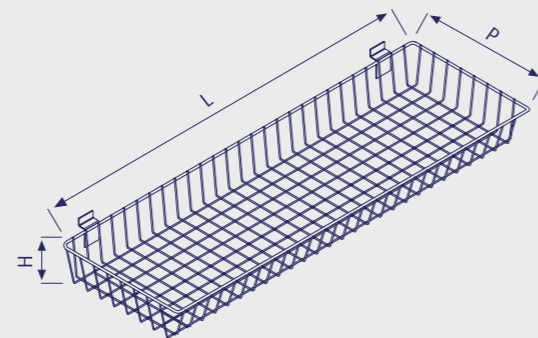

ACCESSORIES
AKSESUAR

**WIRE HOOK FOR
SLATTED WOODEN PANEL**
KANALLI AHŞAP PANOYA
GEÇME KADEMELİ SPOT TEL

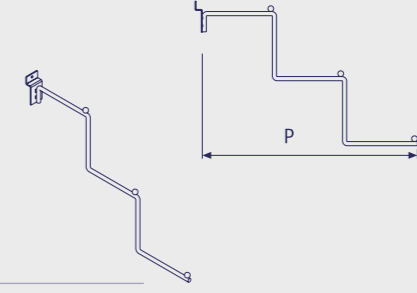

Code / Kod	P	H	L	Description / Açıklama
11D0000030N	300			Chrome coated / Nikel kaplama
11D0000031N	350			Zinc coated / Çinko kaplama
11D0000032N	400			Painted / Boyalı

SHIRT HOLDER FOR SLATTED WOODEN PANEL
KANALLI AHŞAP PANOYA GEÇME GÖMLEK TUTUCU

Code / Kod	P	H	L	Description / Açıklama
11E0000021N	350	250	250	Chrome coated / Nikel kaplama Zinc coated / Çinko kaplama Painted / Boyalı

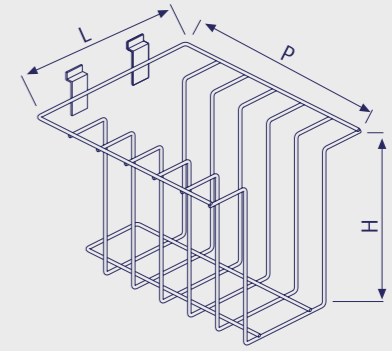

WIRE SEPARATOR FOR WIRE BASKET H: 300
RAF ÜSTÜ SEPET RAF ARA SEPERATÖRÜ H: 300

Code / Kod	P	H	L	Description / Açıklama
11F0000061N	300	300		Chrome coated / Nikel kaplama
11F0000062N	400	300		Zinc coated / Çinko kaplama
11F0000063N	500	300		Painted / Boyalı
11F0000064N	600	300		

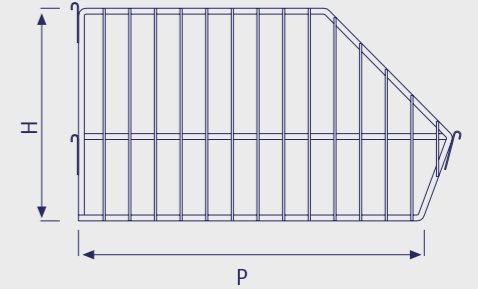

WIRE SEPARATOR FOR WIRE BASKET H: 400
RAF ÜSTÜ SEPET RAF ARA SEPERATÖRÜ H: 400

Code / Kod	P	H	L	Description / Açıklama
11F0000065N	300	400		Chrome coated / Nikel kaplama
11F0000066N	400	400		Zinc coated / Çinko kaplama
11F0000067N	500	400		Painted / Boyalı
11F0000068N	600	400		

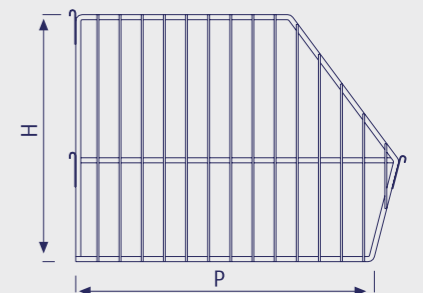



ACCESSORIES
AKSESUAR

WIRE BASKET H: 300
RAF ÜSTÜ SEPET RAF H: 300

Code / Kod	P	H	L	Description / Açıklama
11F0000069N	300	300	500	Chrome coated / Nikel kaplama
11F0000070N	300	300	700	Zinc coated / Çinko kaplama
11F0000071N	300	300	900	Painted / Boyalı
11F0000072N	300	300	1000	* Basket with flat iron support
*11F0000073N	300	300	1250	* İşaretli ürünler Lama takviyeli olacaktır.
*11F0000074N	300	300	1330	
11F0000075N	400	300	500	
11F0000076N	400	300	700	
11F0000077N	400	300	900	
11F0000078N	400	300	1000	
*11F0000079N	400	300	1250	
*11F0000080N	400	300	1330	
11F0000081N	500	300	500	
11F0000082N	500	300	700	
11F0000083N	500	300	900	
11F0000084N	500	300	1000	
*11F0000085N	500	300	1250	
*11F0000086N	500	300	1330	
11F0000087N	600	300	500	
11F0000088N	600	300	700	
11F0000089N	600	300	900	
11F0000090N	600	300	1000	
*11F0000091N	600	300	1250	
*11F0000092N	600	300	1330	

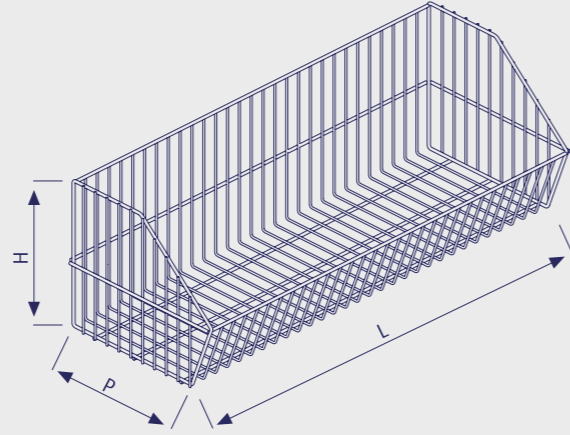

WIRE BASKET H: 400
RAF ÜSTÜ SEPET RAF H: 400

Code / Kod	P	H	L	Description / Açıklama
11F0000093N	300	400	500	Chrome coated / Nikel kaplama
11F0000094N	300	400	700	Zinc coated / Çinko kaplama
11F0000095N	300	400	900	Painted / Boyalı
11F0000096N	300	400	1000	* Basket with flat iron support
*11F0000097N	300	400	1250	* İşaretli ürünler Lama takviyeli olacaktır.
*11F0000098N	300	400	1330	
11F0000099N	400	400	500	
11F0000100N	400	400	700	
11F0000101N	400	400	900	
11F0000102N	400	400	1000	
*11F0000103N	400	400	1250	
*11F0000104N	400	400	1330	
11F0000105N	500	400	500	
11F0000106N	500	400	700	
11F0000107N	500	400	900	
11F0000108N	500	400	1000	
*11F0000109N	500	400	1250	
*11F0000110N	500	400	1330	
11F0000111N	600	400	500	
11F0000112N	600	400	700	
11F0000113N	600	400	900	
11F0000114N	600	400	1000	
*11F0000115N	600	400	1250	
*11F0000116N	600	400	1330	

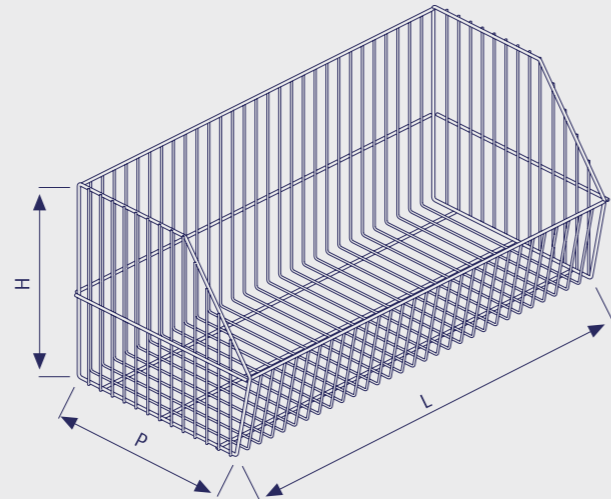

MOVABLE SEPERATOR BOX
HAREKETLİ RAF ÜSTÜ HIRDAVAT RAFI

Code / Kod	P	H	L	Description / Açıklama
5I00000018B	300	173	500	Painted / Boyalı
5I00000019B	300	173	700	
5I00000020B	300	173	900	
5I00000021B	300	173	1000	
5I00000022B	300	173	1250	
5I00000023B	300	173	1330	
5I00000024B	400	173	500	
5I00000025B	400	173	700	
5I00000001B	400	173	900	
5I00000002B	400	173	1000	
5I00000003B	400	173	1250	
5I00000004B	400	173	1330	
5I00000026B	500	173	500	
5I00000027B	500	173	700	
5I00000028B	500	173	900	
5I00000007B	500	173	1000	
5I00000006B	500	173	1250	
5I00000005B	500	173	1330	
5I00000029B	600	173	500	
5I00000030B	600	173	700	
5I00000031B	600	173	900	
5I00000032B	600	173	1000	
5I00000033B	600	173	1250	
5I00000034B	600	173	1330	

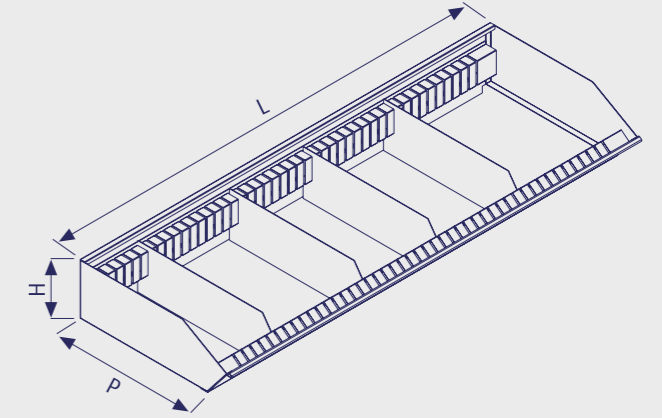

SEPARATOR BOX
SABİT RAF ÜSTÜ HIRDAVAT RAFI

Code / Kod	P	H	L	Description / Açıklama
5I00000035B	300	173	500	Painted / Boyalı
5I00000036B	300	173	700	
5I00000037B	300	173	900	
5I00000038B	300	173	1000	
5I00000039B	300	173	1250	
5I00000040B	300	173	1330	
5I00000041B	400	173	500	
5I00000042B	400	173	700	
5I00000012B	400	173	900	
5I00000013B	400	173	1000	
5I00000014B	400	173	1250	
5I00000043B	400	173	1330	
5I00000044B	500	173	500	
5I00000045B	500	173	700	
5I00000046B	500	173	900	
5I00000017B	500	173	1000	
5I00000016B	500	173	1250	
5I00000015B	500	173	1330	
5I00000047B	600	173	500	
5I00000048B	600	173	700	
5I00000049B	600	173	900	
5I00000050B	600	173	1000	
5I00000051B	600	173	1250	
5I00000052B	600	173	1330	

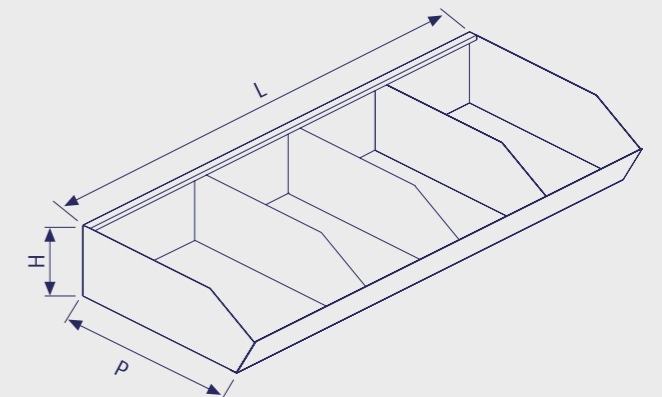

ACCESSORIES
AKSESUAR



ACCESSORIES
AKSESUAR

SEPERATOR FOR MOVABLE SEPERATOR BOX
RAF ÜSTÜ HIRDAVAT RAF SEPERATÖR

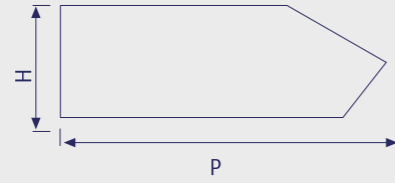

Code / Kod	P	H	L	Description / Açıklama
5100000008B	300	150		Painted / Boyalı
5100000009B	400	150		
5100000010B	500	150		
5100000011B	600	150		

STACKING WIRE STAND
AKSİYON STANDI

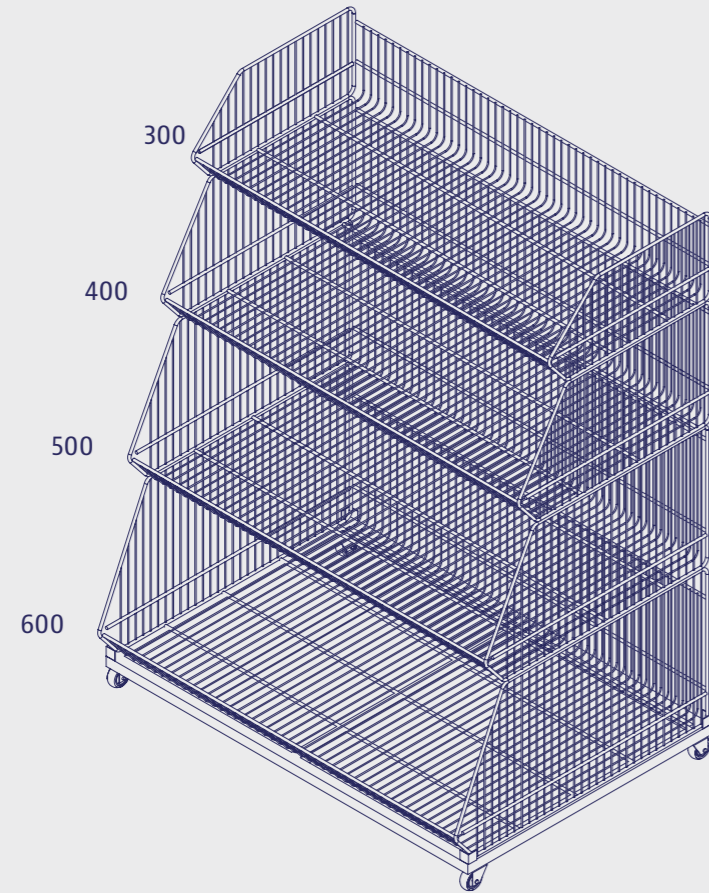

Code / Kod	P	H	L	Description / Açıklama
97000000070	850	1560	1200	Chrome coated / Nikel kaplama Zinc coated / Çinko kaplama Painted / Boyalı

DISPLAY TABLE
PROFİL AYAKLI HAVUZ

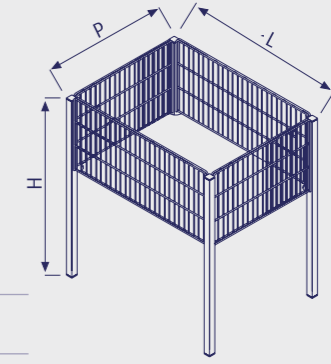

Code / Kod	P	H	L	Description / Açıklama
8B00000001N	600	850	800	Chrome coated / Nikel kaplama
8B00000002N	800	850	800	Zinc coated / Çinko kaplama
8B00000003N	800	850	1200	Painted / Boyalı



ACCESSORIES
AKSESUAR

DISPLAY TABLE
KATLANABİLİR HAVUZ

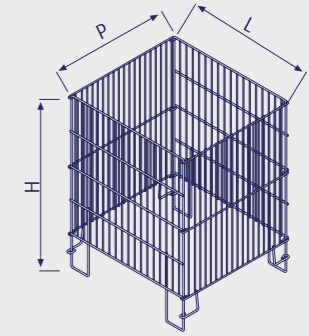

Code / Kod	P	H	L	Description / Açıklama
8B00000004N	530	700	530	Chrome coated / Nikel kaplama
8B00000005N	800	800	800	Zinc coated / Çinko kaplama
8B00000006N	900	900	900	Painted / Boyalı

DISPLAY TABLE
PROFİL H AYAKLI HAVUZ / PROFİL H AYAKLI HAVUZ ÇİFT KATLI

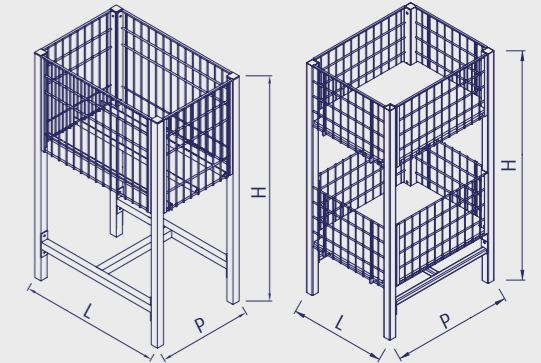

Code / Kod	P	H	L	Description / Açıklama
8B00000016N	400	950	600	Chrome coated / Nikel kaplama
8B00000017N	600	950	1200	Zinc coated / Çinko kaplama
8B00000018N	400	950	500	Painted / Boyalı
				Profil H Ayaklı Havuz
8B00000019N	400	950	600	Profil H Ayaklı Havuz Çift Katlı
8B00000021N	600	950	1200	
8B00000022N	400	950	500	

DISPLAY TABLE
SPOT SEPETİ

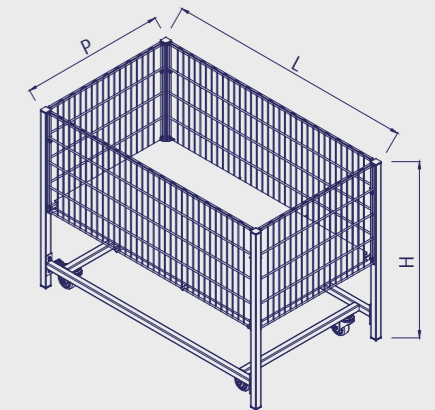

Code / Kod	P	H	L	Description / Açıklama
8B00000008U	700	840	1200	Chrome coated / Nikel kaplama Zinc coated / Çinko kaplama Painted / Boyalı



ACCESSORIES
AKSESUAR

SHOPPING BASKET STACKER
EL SEPETİ ALTLIĞI

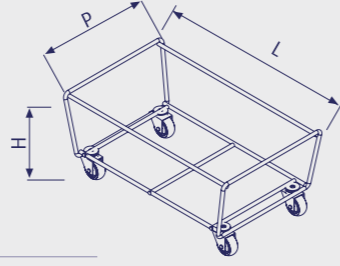

Code / Kod	P	H	L	Description / Açıklama
11H0000001N	280	145	445	Chrome coated / Nikel kaplama Zinc coated / Çinko kaplama Painted / Boyalı

OVAL SHOPPING BASKET STACKER
OVAL EL SEPETİ ALTLIĞI



Code / Kod	P	H	L	Description / Açıklama
97000000076	280	145	445	Chrome coated / Nikel kaplama Painted / Boyalı

ROLLING SHOPPING BASKET (42 lt)
TEKERLEKLİ EL SEPETİ (42 lt)



Code / Kod	P	H	H1	L	Description / Açıklama
97000000024	340	400	860	460	Red / Blue / Green Kırmızı / Mavi / Yeşil

ROLLING SHOPPING BASKET (54 lt)
TEKERLEKLİ EL SEPETİ (54 lt)



Code / Kod	P	H	L	L	Description / Açıklama
97000000003	400	440	550	460	Red / Blue / Green Kırmızı / Mavi / Yeşil

PLASTIC SHOPPING BASKET (22 lt)
PLASTİK EL SEPETİ (22 lt)



Code / Kod	P	H	L	Description / Açıklama
97000000006	300	230	430	Red / Blue / Green / Orange / Yellow Kırmızı / Mavi / Yeşil / Turuncu / Sarı Resim görsel amaçlıdır.

WIRE SHOPPING BASKET (20 lt)
TEL EL SEPETİ (20 lt)

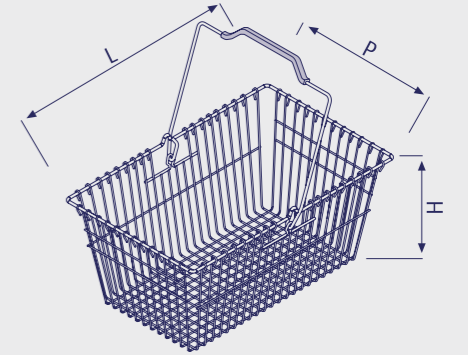

Code / Kod	P	H	L	Description / Açıklama
97000000062	280	210	460	Chrome coated / Nikel kaplama

OVAL WIRE SHOPPING BASKET (20 lt)
OVAL TEL EL SEPETİ (20 lt)



Code / Kod	P	H	L	Description / Açıklama
97000000061	330	240	435	Chrome coated / Nikel kaplama

SHOPPING TROLLEY (25 lt)
MARKET ARABASI (25 lt)

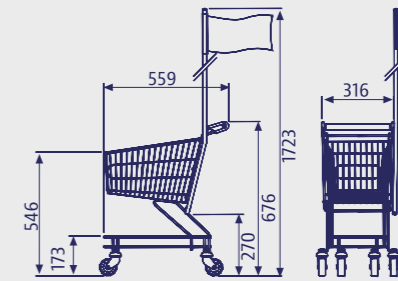

Code / Kod	P	H	L	Description / Açıklama
97000000041				With flag / Bayrak direkli



ACCESSORIES
AKSESUAR

SHOPPING TROLLEY (100 lt)
MARKET ARABASI (100 lt)

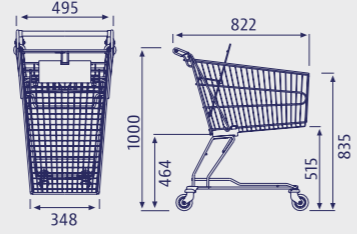

Code / Kod	P	H	L	Description / Açıklama
97000000042	495	1000	816	With baby seat / Bebe setli Customized handle is possible Tutma sapına logo yapılabilir.

SHOPPING TROLLEY (140 lt)
MARKET ARABASI (140 lt)

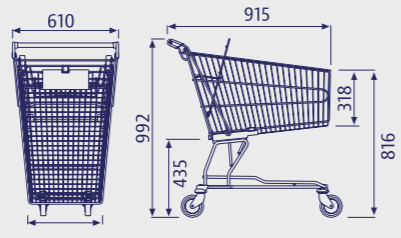

Code / Kod	P	H	L	Description / Açıklama
97000000044	610	992	915	With baby seat / Bebe setli Customized handle is possible Tutma sapına logo yapılabilir.

SHOPPING TROLLEY (160 lt)
MARKET ARABASI (160 lt)

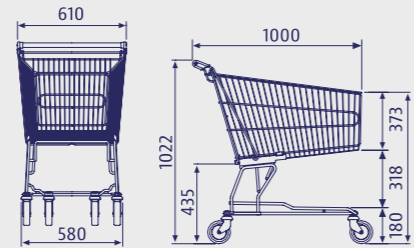

Code / Kod	P	H	L	Description / Açıklama
97000000045	610	1022	1000	

SHOPPING TROLLEY (210 lt)
MARKET ARABASI (210 lt)

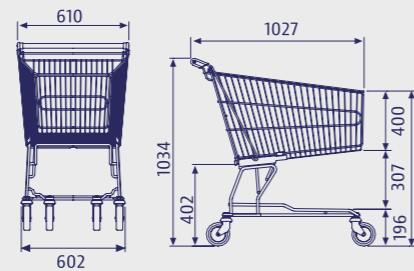

Code / Kod	P	H	L	Description / Açıklama
97000000047	610	1034	1027	

SHOPPING TROLLEY 100 lt
MARKET ARABASI 100 lt



Code / Kod	P	H	L	Description / Açıklama
97000000052	500	985	830	

SHOPPING TROLLEY (150 lt)
MARKET ARABASI (150 lt)



Code / Kod	P	H	L	Description / Açıklama
97000000149				

ROLL TAINER
KARTON TAŞIMA ARABASI

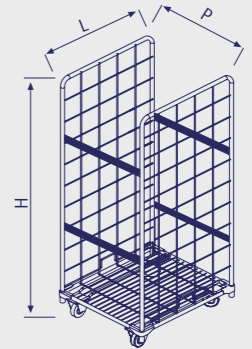

Code / Kod	P	H	L	Description / Açıklama
97000000065	700	1700	800	450 kg

ROLL TAINER
KARTON TAŞIMA ARABASI

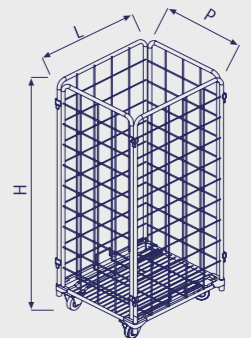

Code / Kod	P	H	L	Description / Açıklama
97000000066	700	1700	800	350 kg



ACCESSORIES
AKSESUAR

TRANSPORT TROLLEY
YÜK TAŞIMA ARABASI

Code / Kod	P	H	L	Description / Açıklama
97000000103	1110	980	670	350 kg

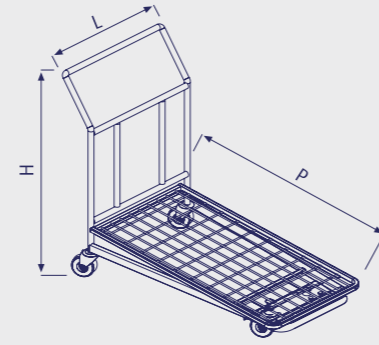

TRANSPORT TROLLEY
YÜK TAŞIMA ARABASI

Code / Kod	P	H	L	Description / Açıklama
97000000067	700	890	430	250 kg

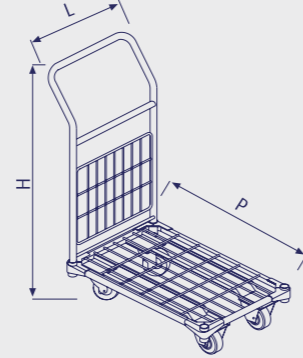

TRANSPORT TROLLEY
YÜK TAŞIMA ARABASI

Code / Kod	P	H	L	Description / Açıklama
97000000069	950	960	600	250 kg

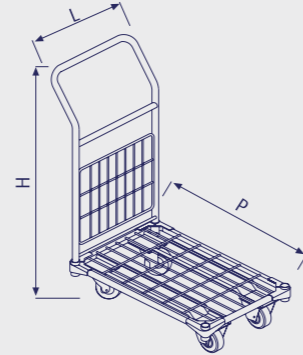

TRANSPORT TROLLEY
YÜK TAŞIMA ARABASI

Code / Kod	P	H	L	Description / Açıklama
97000000104	970	880	540	300 kg

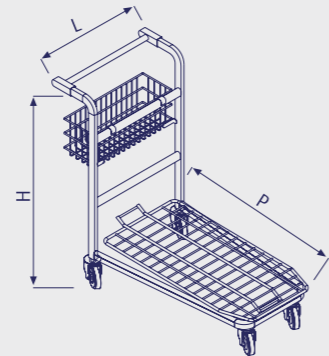

TRANSPORT TROLLEY
YÜK TAŞIMA ARABASI

Code / Kod	P	H	L	Description / Açıklama
97000000105	1185	985	800	600 kg

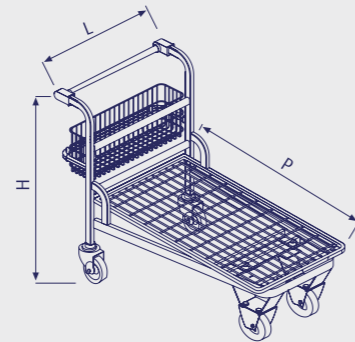

ACCESSORIES
AKSESUAR

TRANSPORT TROLLEY
YÜK TAŞIMA ARABASI

Code / Kod	P	H	L	L	Description / Açıklama
97000000102	1185	985	800	650	With 5 wheels / 5 Tekerlekli 500 kg

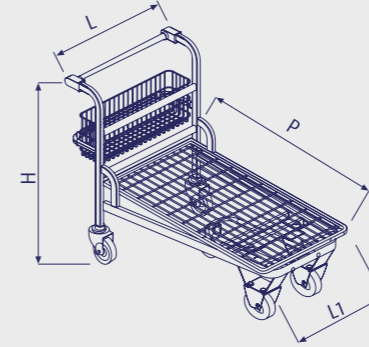

TRANSPORT TROLLEY
YUVARLAK TEL STAND

Code / Kod	P	H	L	Description / Açıklama
8J00000001U		1850	820	

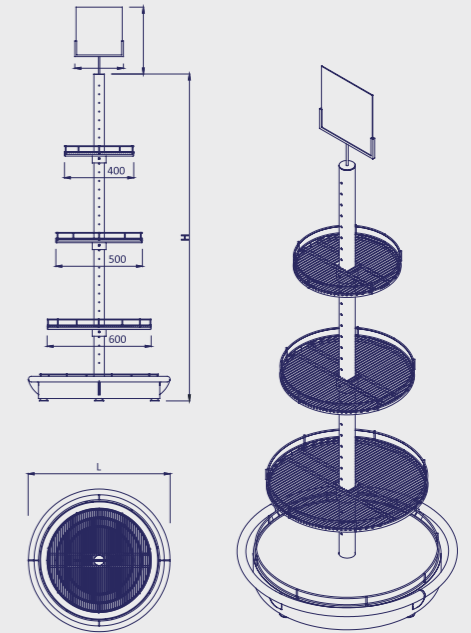

DISPLAY PALLET
PROMOSYON PALETİ

Code / Kod	P	H	L	Description / Açıklama
8C00000001M	600	200	800	Top can be covered with aluminum
8C00000002M	800	200	1200	Üstü Alüminyum levha ile kaplanabilir
8C00000003M	1000	200	1200	

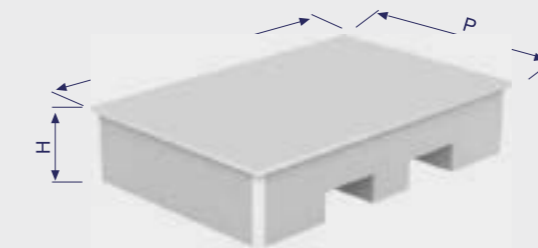



**STORE
SYSTEMS**
MAĐAZA
SİSTEMLERİ



STORE
SYSTEMS
MAĞAZA
SİSTEMLERİ

WOODEN UNIT WELDED UPRIGHT (30X60)
AĖŞAP AYAK (30 0)

Code / Kod	P	H	L	Description / Açıklama
3R0000020B	250	1430		
3R0000022B	350	1430		
3R0000024B	450	1430		
3R0000026B	550	1430		
3R0000029B	250	1640		
3R0000031B	350	1640		
3R0000033B	450	1640		
3R0000035B	550	1640		
3R0000038B	250	1850		
3R0000040B	350	1850		
3R0000042B	450	1850		
3R0000044B	550	1850		

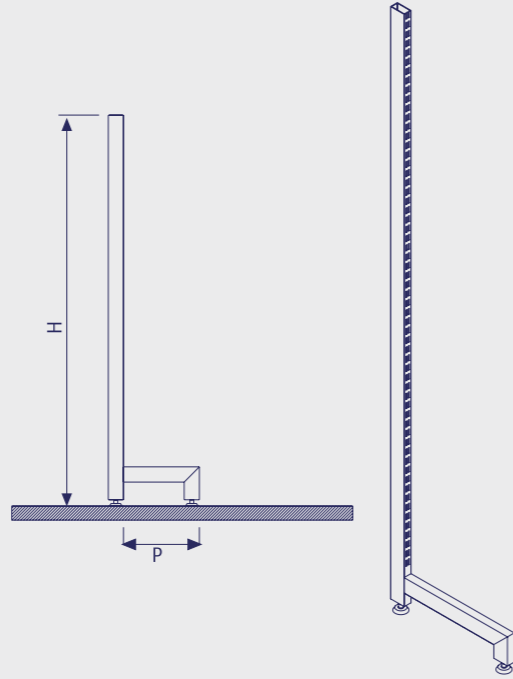

STORE
SYSTEMS
MAĞAZA
SİSTEMLERİ

WOODEN UNIT WELDED UPRIGHT (30X80)
AĖŞAP AYAK (30 0)

Code / Kod	P	H	L	Description / Açıklama
3R0000110B	250	1430		
3R0000112B	350	1430		
3R0000114B	450	1430		
3R0000116B	550	1430		
3R0000119B	250	1640		
3R0000121B	350	1640		
3R0000123B	450	1640		
3R0000125B	550	1640		
3R0000128B	250	1850		
3R0000130B	350	1850		
3R0000132B	450	1850		
3R0000134B	550	1850		

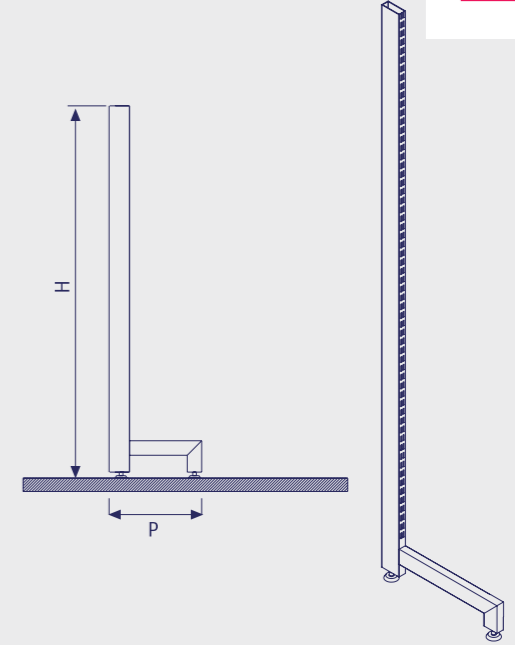

WOODEN UNIT WELDED UPRIGHT (30X60)
AĖŞAP AYAK (30 0)

Code / Kod	P	H	L	Description / Açıklama
3R0000047B	250	2060		
3R0000049B	350	2060		
3R0000051B	450	2060		
3R0000053B	550	2060		
3R0000056B	250	2270		
3R0000058B	350	2270		
3R0000060B	450	2270		
3R0000062B	550	2270		

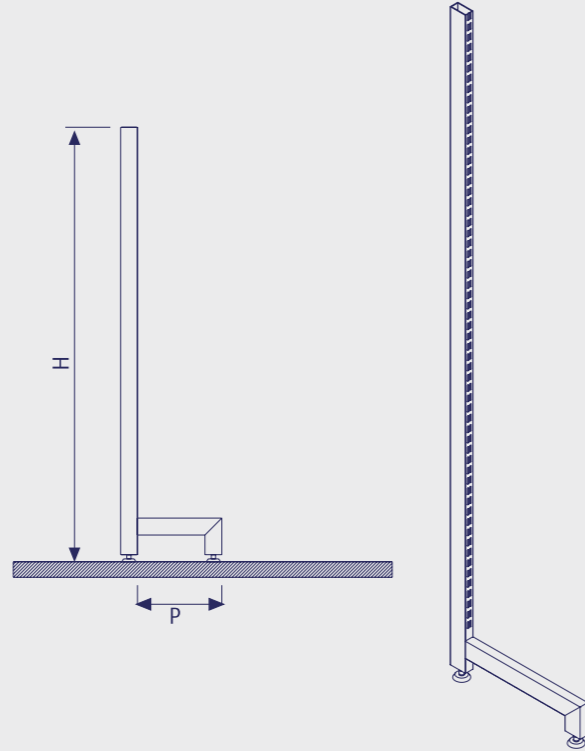

WOODEN UNIT WELDED UPRIGHT (30X80)
AĖŞAP AYAK (30 0)

Code / Kod	P	H	L	Description / Açıklama
3R0000137B	250	2060		
3R0000139B	350	2060		
3R0000141B	450	2060		
3R0000143B	550	2060		
3R0000146B	250	2270		
3R0000148B	350	2270		
3R0000150B	450	2270		
3R0000152B	550	2270		
3R0000155B	250	2480		
3R0000157B	350	2480		
3R0000159B	450	2480		
3R0000161B	550	2480		

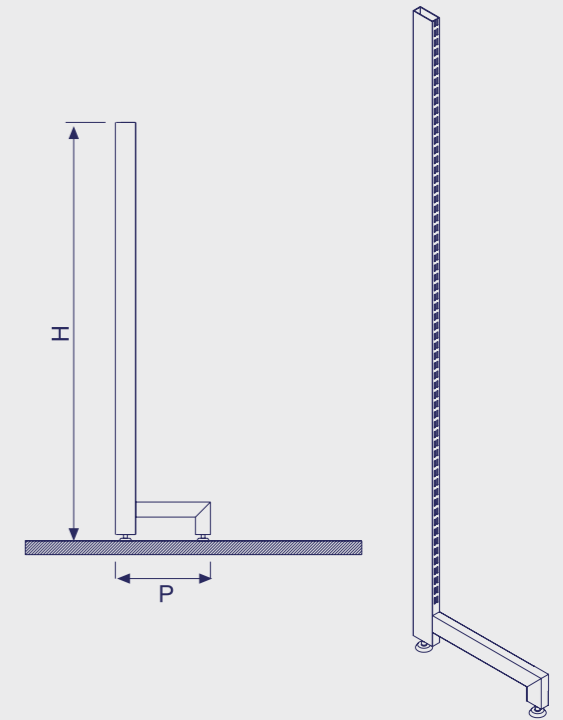



STORE
SYSTEMS
MAĞAZA
SİSTEMLERİ

WOODEN UNIT WELDED UPRIGHT DOUBLE SIDED (30X60)
ÇİFT YÖNLÜ AHŞAP AYAK (30X 0)

Code / Kod	P	H	L	Description / Açıklama
3S00000020B	250	1430		
3S00000022B	350	1430		
3S00000024B	450	1430		
3S00000026B	550	1430		
3S00000029B	250	1640		
3S00000031B	350	1640		
3S00000033B	450	1640		
3S00000035B	550	1640		
3S00000038B	250	1850		
3S00000040B	350	1850		
3S00000042B	450	1850		
3S00000044B	550	1850		

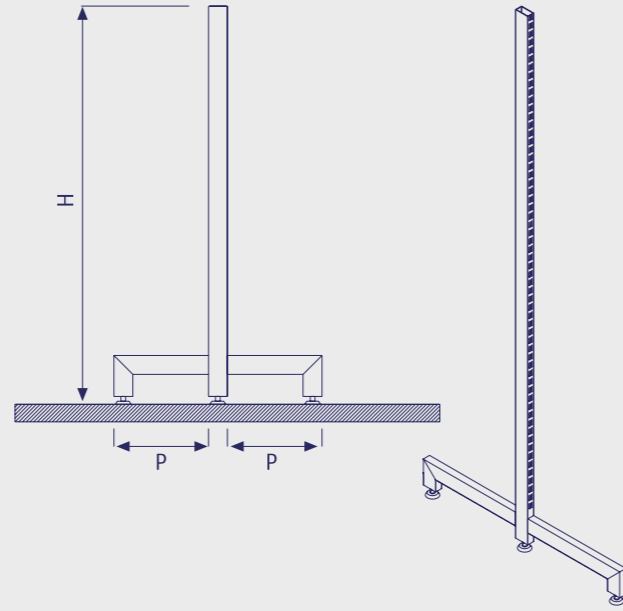

STORE
SYSTEMS
MAĞAZA
SİSTEMLERİ

WOODEN UNIT WELDED UPRIGHT DOUBLE SIDED (30X80)
ÇİFT YÖNLÜ AHŞAP AYAK (30X 0)

Code / Kod	P	H	L	Description / Açıklama
3S00000110B	250	1430		
3S00000112B	350	1430		
3S00000114B	450	1430		
3S00000116B	550	1430		
3S00000119B	250	1640		
3S00000121B	350	1640		
3S00000123B	450	1640		
3S00000125B	550	1640		
3S00000128B	250	1850		
3S00000130B	350	1850		
3S00000132B	450	1850		
3S00000134B	550	1850		

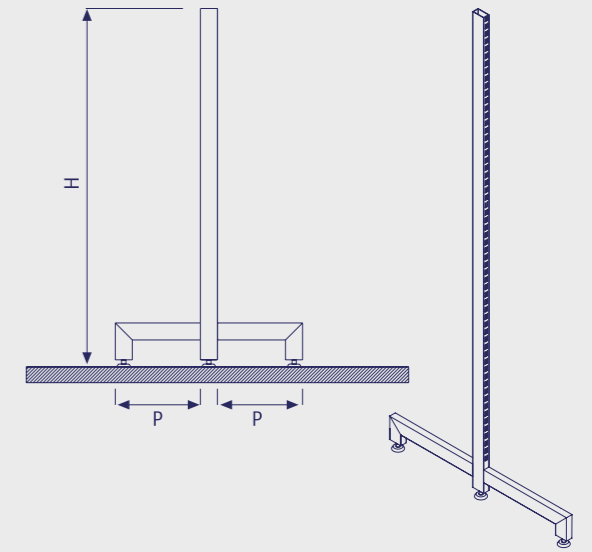

WOODEN UNIT WELDED UPRIGHT DOUBLE SIDED (30X60)
ÇİFT YÖNLÜ AHŞAP AYAK (30X 0)

Code / Kod	P	H	L	Description / Açıklama
3S00000047B	250	2060		
3S00000049B	350	2060		
3S00000051B	450	2060		
3S00000053B	550	2060		
3S00000056B	250	2270		
3S00000058B	350	2270		
3S00000060B	450	2270		
3S00000062B	550	2270		

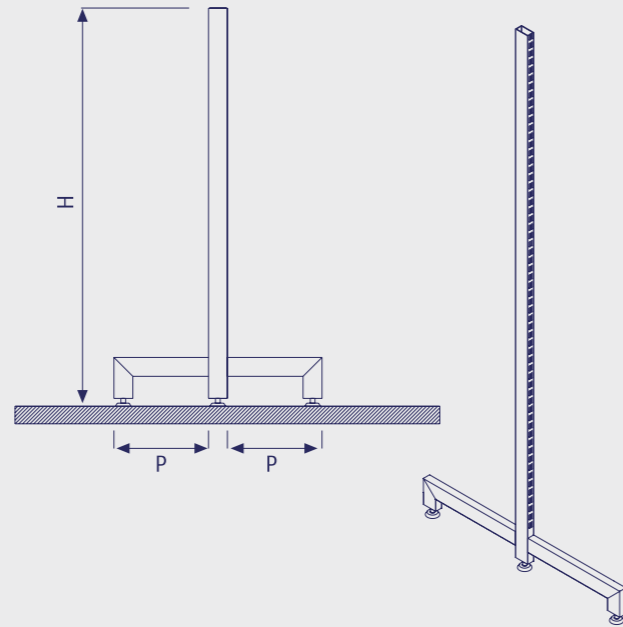

WOODEN UNIT WELDED UPRIGHT DOUBLE SIDED (30X80)
ÇİFT YÖNLÜ AHŞAP AYAK (30X 0)

Code / Kod	P	H	L	Description / Açıklama
3S00000137B	250	2060		
3S00000139B	350	2060		
3S00000141B	450	2060		
3S00000143B	550	2060		
3S00000146B	250	2270		
3S00000148B	350	2270		
3S00000150B	450	2270		
3S00000152B	550	2270		
3S00000155B	250	2480		
3S00000157B	350	2480		
3S00000159B	450	2480		
3S00000161B	550	2480		

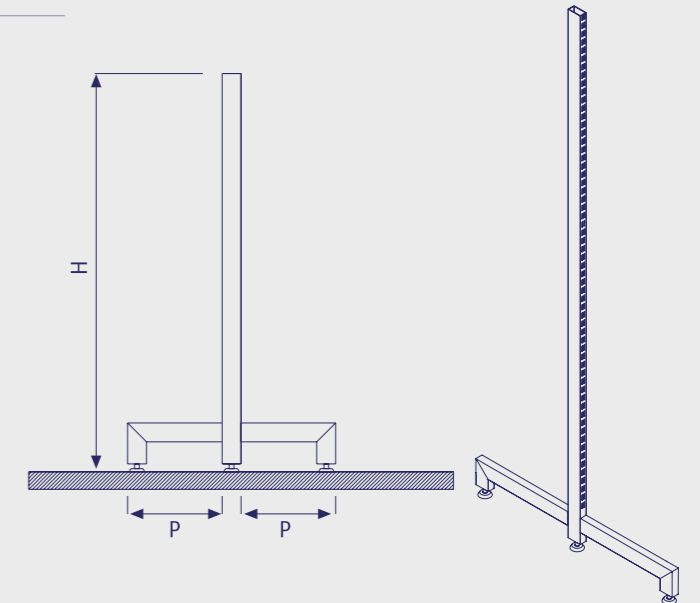



STORE
SYSTEMS
MAĞAZA
SİSTEMLERİ

WOODEN BACK PANEL 18 mm
AHŞAP ARKA PANO MDF 1 mm

Code / Kod	P	H	L	Description / Açıklama
4R0000001M		1430	700	
4R0000003M		1640	700	
4R0000005M		1850	700	
4R0000007M		2060	700	
4R0000009M		2270	700	
4R0000011M		2480	700	
4R0000013M		1430	900	
4R0000015M		1640	900	
4R0000017M		1850	900	
4R0000019M		2060	900	
4R0000021M		2270	900	
4R0000023M		2480	900	
4R0000025M		1430	1000	
4R0000027M		1640	1000	
4R0000029M		1850	1000	
4R0000031M		2060	1000	
4R0000033M		2270	1000	
4R0000035M		2480	1000	

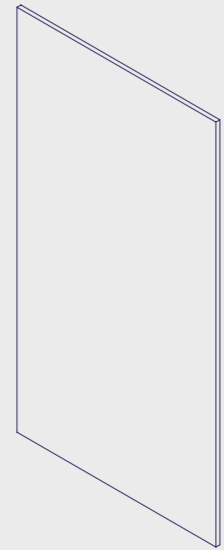
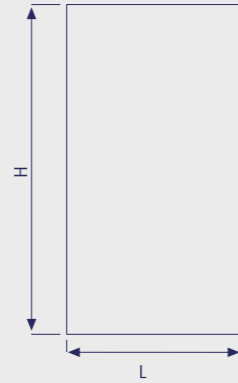

STORE
SYSTEMS
MAĞAZA
SİSTEMLERİ

SLATTED WOODEN BACK PANEL 18 mm
AHŞAP KANALLI ARKA PANO 1 mm

Code / Kod	P	H	L	Description / Açıklama
4R0000055M		1430	700	Grove centre is 15 cm
4R0000056M		1640	700	Kanal aralığı 15 cm
4R0000057M		1850	700	
4R0000058M		2060	700	
4R0000059M		2270	700	
4R0000060M		2480	700	
4R0000061M		1430	900	
4R0000062M		1640	900	
4R0000063M		1850	900	
4R0000064M		2060	900	
4R0000065M		2270	900	
4R0000066M		2480	900	
4R0000067M		1430	1000	
4R0000068M		1640	1000	
4R0000069M		1850	1000	
4R0000070M		2060	1000	
4R0000071M		2270	1000	
4R0000072M		2480	1000	

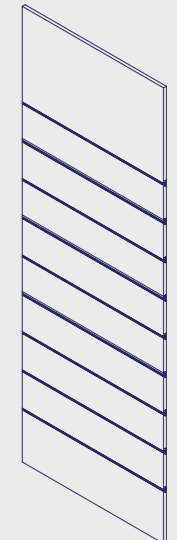
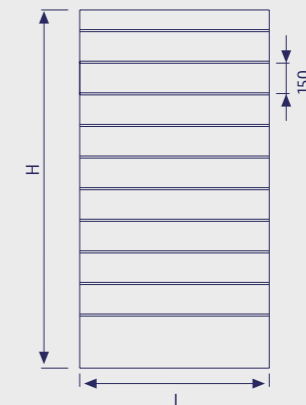

SLATTED WOODEN BACK PANEL 18 mm
AHŞAP KANALLI ARKA PANO 1 mm

Code / Kod	P	H	L	Description / Açıklama
4R0000037M		1430	700	Grove centre is 10 cm
4R0000038M		1640	700	Kanal aralığı 10 cm
4R0000039M		1850	700	
4R0000040M		2060	700	
4R0000041M		2270	700	
4R0000042M		2480	700	
4R0000043M		1430	900	
4R0000044M		1640	900	
4R0000045M		1850	900	
4R0000046M		2060	900	
4R0000047M		2270	900	
4R0000048M		2480	900	
4R0000049M		1430	1000	
4R0000050M		1640	1000	
4R0000051M		1850	1000	
4R0000052M		2060	1000	
4R0000053M		2270	1000	
4R0000054M		2480	1000	

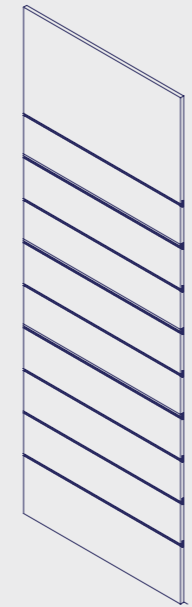
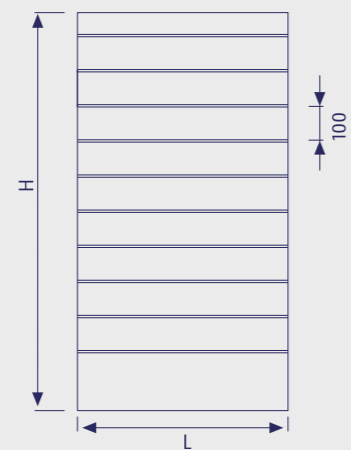

SLATTED WOODEN BACK PANEL 18 mm
AHŞAP KANALLI ARKA PANO 1 mm

Code / Kod	P	H	L	Description / Açıklama
4R0000073M		1430	700	Grove centre is 20 cm
4R0000074M		1640	700	Kanal aralığı 20 cm
4R0000075M		1850	700	
4R0000076M		2060	700	
4R0000077M		2270	700	
4R0000078M		2480	700	
4R0000079M		1430	900	
4R0000080M		1640	900	
4R0000081M		1850	900	
4R0000082M		2060	900	
4R0000083M		2270	900	
4R0000084M		2480	900	
4R0000085M		1430	1000	
4R0000086M		1640	1000	
4R0000087M		1850	1000	
4R0000088M		2060	1000	
4R0000089M		2270	1000	
4R0000090M		2480	1000	

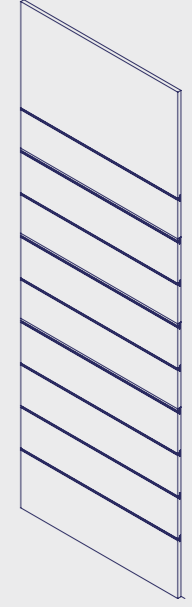
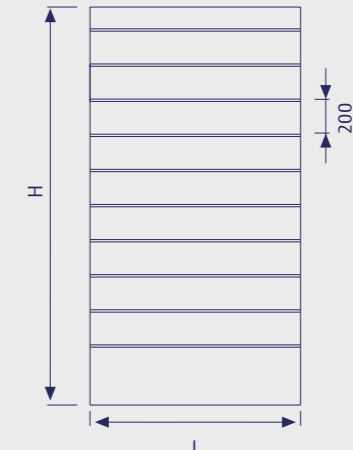



STORE
SYSTEMS
MAĞAZA
SİSTEMLERİ

WOODEN BACK PANEL WITH SINGLE INNER ALUMINUM ORTASI ALÜMİNYUMLU AHŞAP ARKA PANO

Code / Kod	P	H	L	Description / Açıklama
4R00000205M		1430	870	
4R00000206M		1640	870	
4R00000207M		1850	870	
4R00000208M		2060	870	
4R00000209M		2270	870	
4R00000210M		2480	870	
4R00000211M		1430	970	
4R00000212M		1640	970	
4R00000213M		1850	970	
4R00000214M		2060	970	
4R00000215M		2270	970	
4R00000216M		2480	970	

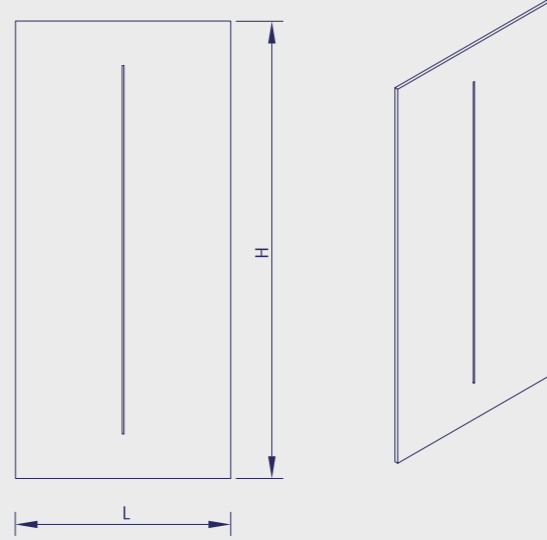

WOODEN BACK PANEL WITH DOUBLE INNER ALUMINUM ORTASI ÇİFT ALÜMİNYUMLU AHŞAP ARKA PANO

Code / Kod	P	H	L	Description / Açıklama
4R00000217M		1430	870	Distance Between Aluminum 700 mm
4R00000218M		1640	870	Alüminyumlar Arası Mesafe 700 mm
4R00000219M		1850	870	
4R00000220M		2060	870	
4R00000221M		2270	870	
4R00000222M		2480	870	
4R00000223M		1430	970	Distance Between Aluminum 800 mm
4R00000224M		1640	970	Alüminyumlar Arası Mesafe 800 mm
4R00000225M		1850	970	
4R00000226M		2060	970	
4R00000227M		2270	970	
4R00000228M		2480	970	

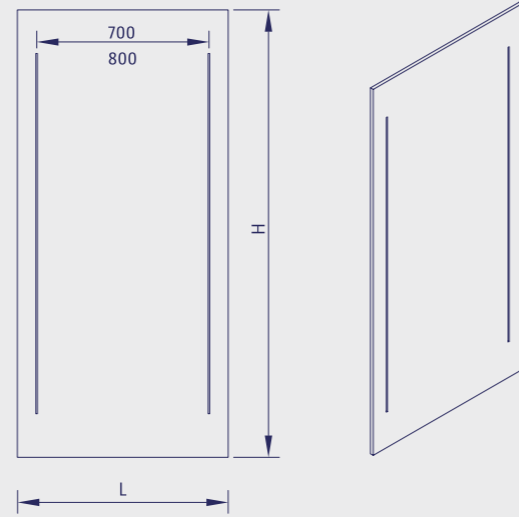

WOODEN BACK PANEL HOLDER BRACKET 3 TIRNAKLI AHŞAP ARKA PANO TUTUCU

Code / Kod	P	H	L	Description / Açıklama
19D0000007G		90		
19D0000008G		90		

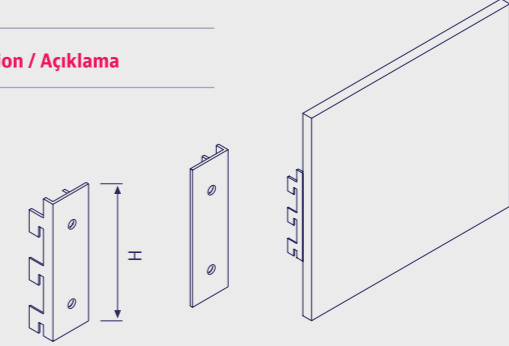

WOODEN BACK PANEL HOLDER BRACKET AHŞAP ARKA PANO TUTUCU TIRNAK

Code / Kod	P	H	L	Description / Açıklama
19B0000001B		630		
19B0000002B		630		

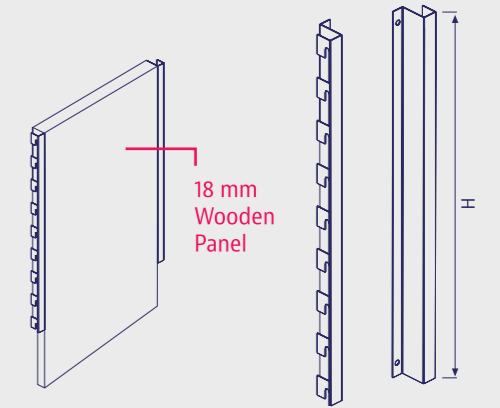

BRACKET FOR WOODEN SHELF WITH 2 HOLDERS AHŞAP RAF KONSOLU 2 TIRNAKLI

Code / Kod	P	H	L	Description / Açıklama
6B00000009B	200			Sağ / Right
6B00000011B	300			
6B00000010B	200			Sol / Left
6B00000012B	300			

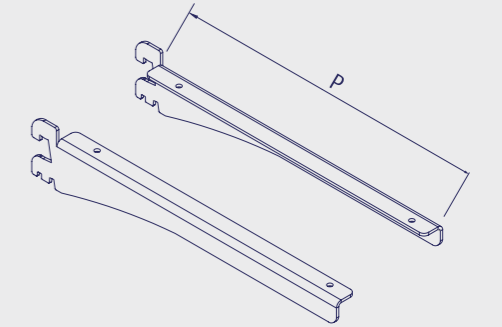

BRACKET FOR WOODEN SHELF WITH 3 HOLDERS AHŞAP RAF KONSOLU 3 TIRNAKLI

Code / Kod	P	H	L	Description / Açıklama
6B00000028B	350			Sağ / Right
6B00000026B	450			
6B00000032B	350			Sol / Left
6B00000030B	450			

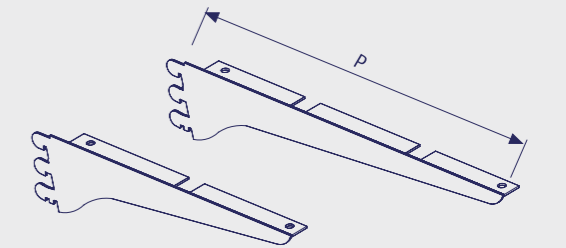

STORE
SYSTEMS
MAĞAZA
SİSTEMLERİ



**STORE
SYSTEMS**
MAĞAZA
SİSTEMLERİ

Code / Kod	P	H	L	Description / Açıklama
6A00000028B	150			Sağ / Right
6A00000030B	200			
6A00000032B	250			
6A00000026B	300			
6A00000034B	350			
6A00000036B	400			
6A00000029B	150			Sol / Left
6A00000031B	200			
6A00000033B	250			
6A00000027B	300			
6A00000035B	350			
6A00000037B	400			

**BRACKET FOR WOODEN &
GLASS SHELF SUITABLE FOR
SLATTED WOODEN PANEL**
KANALLI PANOYA GEÇME AĞŞAP &
CAM RAF KONSOLU

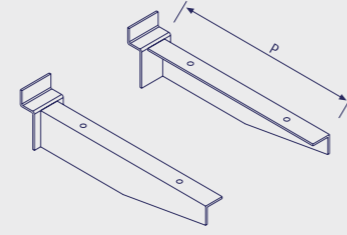

CORNER ALUMINUM
ALÜMİNYUM KÖŞE DÖNÜŞ PROFİLİ

Code / Kod	P	H	L	Description / Açıklama
91000000760		6000		Used with 18 mm wooden panel 18 mm ağşap pano ile kullanılır.

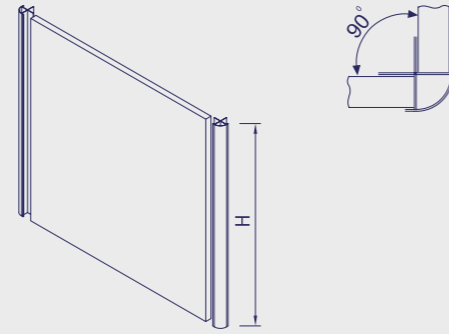

MIDDLE ALUMINUM
ALÜMİNYUM SUNTA BİRLEŞTİRME PROFİLİ (1 mm)

Code / Kod	P	H	L	Description / Açıklama
91000000755		6000		Used with 18 mm wooden panel 18 mm ağşap pano ile kullanılır.

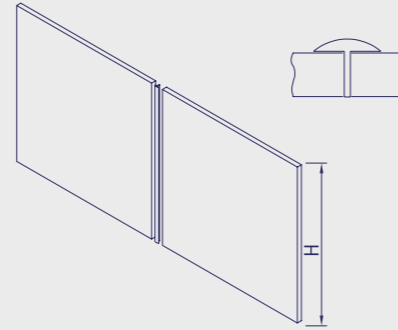

SIDE ALUMINUM
ALÜMİNYUM KÖŞE BİTİŞ PROFİLİ

Code / Kod	P	H	L	Description / Açıklama
91000000762		6000		Used with 18 mm wooden panel 18 mm ağşap pano ile kullanılır.

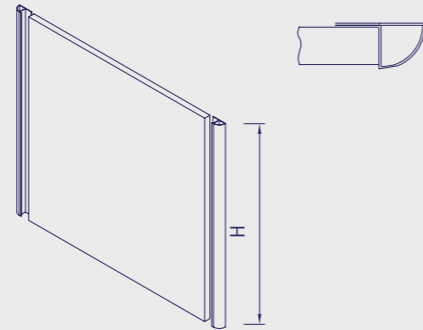

**STORE
SYSTEMS**
MAĞAZA
SİSTEMLERİ

GLASS & PLEXY BACK PANEL HOLDER
CAM VE PLEKSİ ARKA PANO TUTUCU

Code / Kod	P	H	L	Description / Açıklama
19C0000001B			500	Alt
19C0000003B			700	
19C0000007B			900	
19C0000009B			1000	
19C0000021B			1250	
19C0000002B			500	Üst
19C0000004B			700	
19C0000008B			900	
19C0000010B			1000	
19C0000022B			1250	

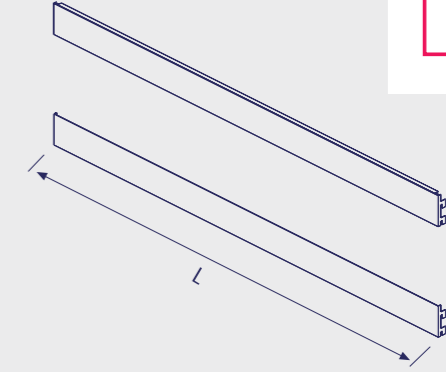

GLASS BACK PANEL (4 mm)
CAM ARKA PANO (4 mm)

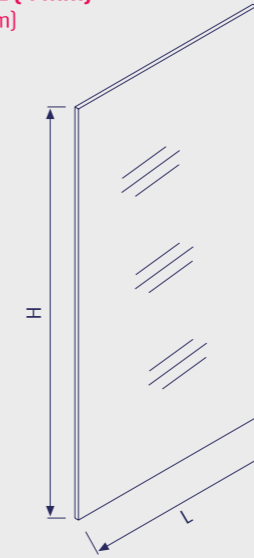

Code / Kod	P	H	L	Description / Açıklama
4S00000033T	1430	700		Can be transparent or frosted Şeffaf ya da kumlu olabilir.
4S00000002T	1430	900		
4S00000003T	1430	1000		
4S00000004T	1640	700		
4S00000005T	1640	900		
4S00000006T	1640	1000		
4S00000007T	1850	700		
4S00000008T	1850	900		
4S00000009T	1850	1000		
4S00000010T	2060	700		
4S00000011T	2060	900		
4S00000012T	2060	1000		
4S00000013T	2270	700		
4S00000014T	2270	900		
4S00000015T	2270	1000		

PLEXY BACK PANEL (4 mm)
PLEKSİ ARKA PANO (4 mm)

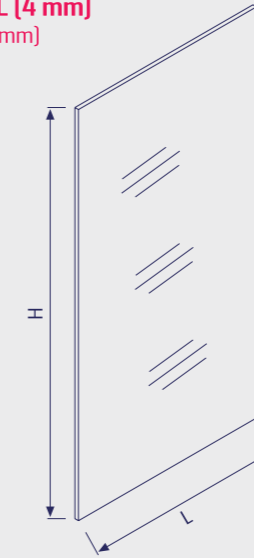

Code / Kod	P	H	L	Description / Açıklama
4T00000002T	1430	700		Colour alternatives are possible Renk alternatifleri mevcuttur.
4T00000004T	1430	900		
4T00000005T	1430	1000		
4T00000012T	1640	700		
4T00000014T	1640	900		
4T00000015T	1640	1000		
4T00000017T	1850	700		
4T00000019T	1850	900		
4T00000020T	1850	1000		
4T00000022T	2060	700		
4T00000024T	2060	900		
4T00000025T	2060	1000		
4T00000007T	2270	700		
4T00000009T	2270	900		
4T00000010T	2270	1000		



STORE
SYSTEMS
MAĞAZA
SİSTEMLERİ

GLASS SHELF (STRAIGHT) 6 mm
CAM RAF (DÜZ) mm

Code / Kod	P	H	L	Description / Açıklama
5F00000001T	200		500	Glass shelf can be transparent or frosted Cam raflar şeffaf ya da kumlu olabilir.
5F00000002T	200		700	
5F00000003T	200		900	
5F00000004T	200		1000	
5F00000005T	300		500	
5F00000006T	300		700	
5F00000007T	300		900	
5F00000008T	300		1000	
5F00000009T	400		500	
5F00000010T	400		700	
5F00000011T	400		900	
5F00000012T	400		1000	
5F00000013T	500		500	
5F00000014T	500		700	
5F00000015T	500		900	
5F00000016T	500		1000	

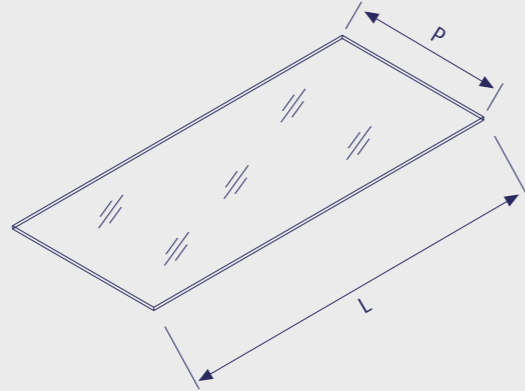

GLASS SHELF (STRAIGHT) 8 mm
CAM RAF (DÜZ) mm

Code / Kod	P	H	L	Description / Açıklama
5F00000033T	200		500	Glass shelf can be transparent or frosted Cam raflar şeffaf ya da kumlu olabilir.
5F00000034T	200		700	
5F00000035T	200		900	
5F00000036T	200		1000	
5F00000037T	300		500	
5F00000038T	300		700	
5F00000039T	300		900	
5F00000040T	300		1000	
5F00000041T	400		500	
5F00000042T	400		700	
5F00000043T	400		900	
5F00000044T	400		1000	
5F00000045T	500		500	
5F00000046T	500		700	
5F00000047T	500		900	
5F00000048T	500		1000	

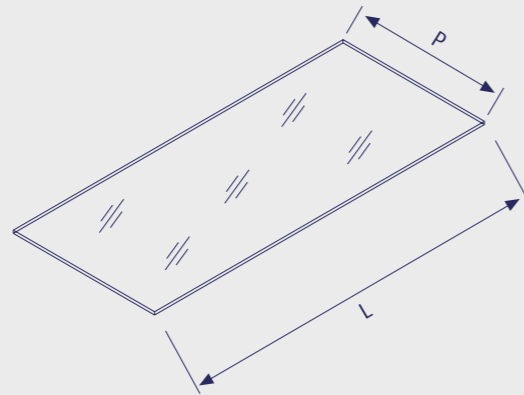

GLASS SHELF (OVAL) 6 mm
OVAL CAM RAF mm

Code / Kod	P	P1	L	Description / Açıklama
5F00000069T	300	250	500	Glass shelf can be transparent or frosted Cam raflar şeffaf ya da kumlu olabilir.
5F00000070T	300	250	700	
5F00000071T	300	250	900	
5F00000072T	300	250	1000	

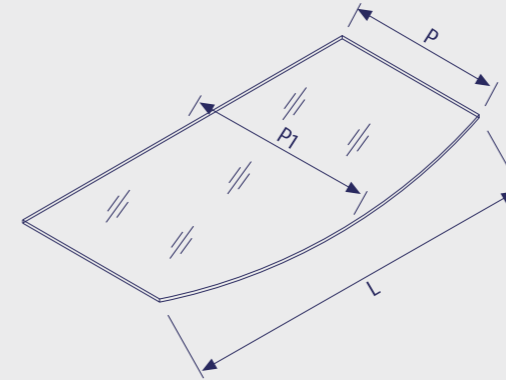

GLASS SHELF (OVAL) 8 mm
OVAL CAM RAF mm

Code / Kod	P	P1	L	Description / Açıklama
5F00000101T	300	250	500	Glass shelf can be transparent or frosted Cam raflar şeffaf ya da kumlu olabilir.
5F00000102T	300	250	700	
5F00000103T	300	250	900	
5F00000104T	300	250	1000	

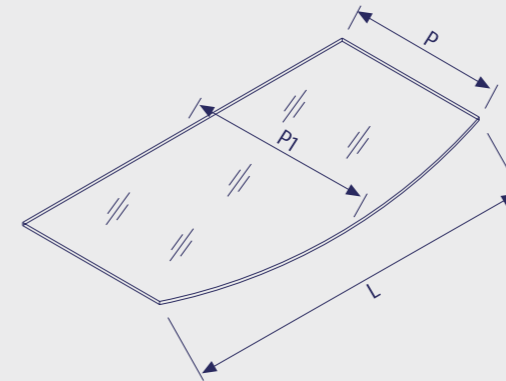

STORE
SYSTEMS
MAĞAZA
SİSTEMLERİ



STORE
SYSTEMS
MAĞAZA
SİSTEMLERİ

FRAME FOR GLASS SHELF CAM RAF İSKELETİ

Code / Kod	P	P1	L	Description / Açıklama
6D0000001B	200		500	With single support / Tek destekli
6D0000002B	200		700	
6D0000003B	200		900	
6D0000004B	200		1000	
6D0000005B	200		1250	
6D0000006B	300		500	With single support / Tek destekli
6D0000007B	300		700	
6D0000008B	300		900	
6D0000009B	300		1000	
6D0000010B	300		1250	

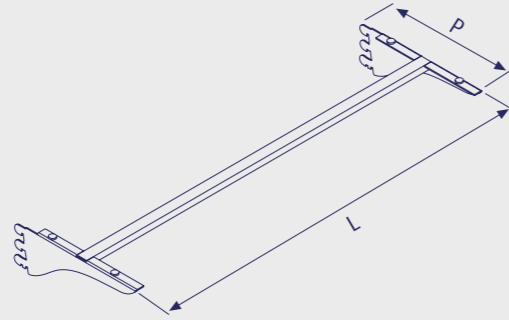

FRAME FOR GLASS SHELF CAM RAF İSKELETİ

Code / Kod	P	P1	L	Description / Açıklama
6D0000011B	400		500	With double support / Çift destekli
6D0000012B	400		700	
6D0000013B	400		900	
6D0000014B	400		1000	
6D0000015B	400		1250	
6D0000016B	500		500	With double support / Çift destekli
6D0000017B	500		700	
6D0000018B	500		900	
6D0000019B	500		1000	
6D0000020B	500		1250	

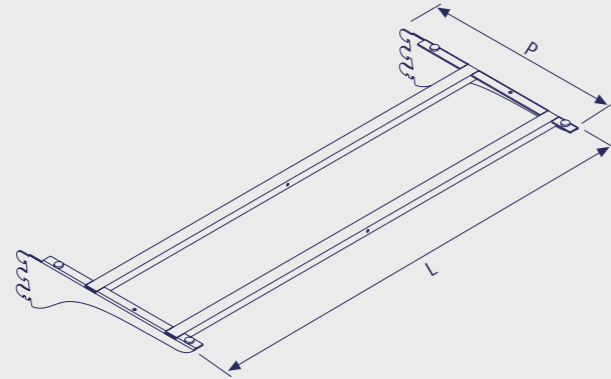

WOODEN BASE SHELF LEFT SIDE CLOSED AHŞAP BAZA RAFI SOL KAPALI

Code / Kod	P	H	L	Description / Açıklama
5G0000028M	500	160	900	18 mm MDF
5G0000029M	500	160	700	
5G0000030M	400	160	900	
5G0000031M	400	160	700	
5G0000032M	300	160	900	
5G0000033M	300	160	700	
5G0000034M	500	172	900	30 mm SNT
5G0000035M	500	172	700	
5G0000036M	400	172	900	
5G0000037M	400	172	700	
5G0000038M	300	172	900	
5G0000039M	300	172	700	

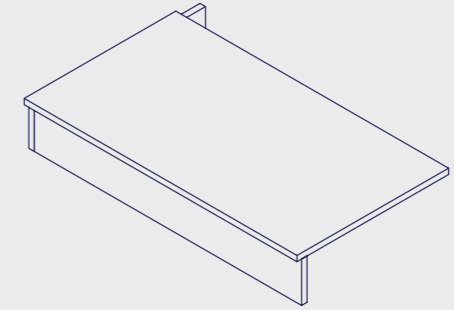
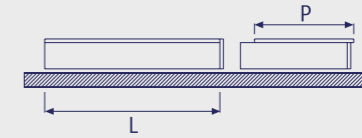

WOODEN BASE SHELF RIGHT SIDE CLOSED AHŞAP BAZA RAFI SAĞ KAPALI

Code / Kod	P	H	L	Description / Açıklama
5G0000046M	500	160	900	18 mm MDF
5G0000047M	500	160	700	
5G0000048M	400	160	900	
5G0000049M	400	160	700	
5G0000050M	300	160	900	
5G0000051M	300	160	700	
5G0000052M	500	172	900	30 mm SNT
5G0000053M	500	172	700	
5G0000054M	400	172	900	
5G0000055M	400	172	700	
5G0000056M	300	172	900	
5G0000057M	300	172	700	

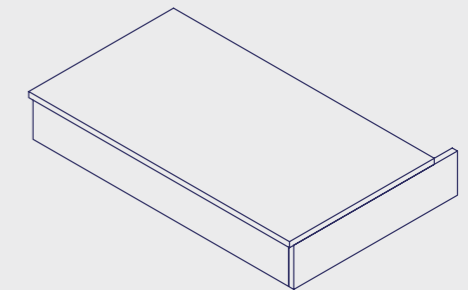
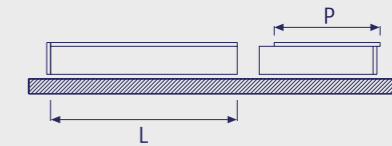

STORE
SYSTEMS
MAĞAZA
SİSTEMLERİ



STORE
SYSTEMS
MAĞAZA
SİSTEMLERİ

WOODEN BASE SHELF MIDDLE
AĞSAP BAZA RAFI ORTA

Code / Kod	P	H	L	Description / Açıklama
5G00000064M	500	160	900	18 mm MDF
5G00000065M	500	160	700	
5G00000066M	400	160	900	
5G00000067M	400	160	700	
5G00000068M	300	160	900	
5G00000069M	300	160	700	
5G00000070M	500	172	900	30 mm SNT
5G00000071M	500	172	700	
5G00000072M	400	172	900	
5G00000073M	400	172	700	
5G00000074M	300	172	900	
5G00000075M	300	172	700	

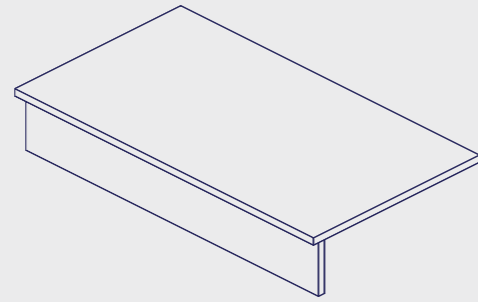
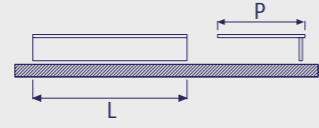

WOODEN SHELF LAMINATED (FULL RADIUS EDGE)
AĞSAP RAF LAMİNANT (TAM RADÜSLÜ)

Code / Kod	P	H	L	Description / Açıklama
5G00000019M	500		1000	30 mm MDF
5G00000020M	500		900	
5G00000021M	500		700	
5G00000022M	400		1000	
5G00000023M	400		900	
5G00000024M	400		700	
5G00000025M	300		1000	
5G00000026M	300		900	
5G00000027M	300		700	

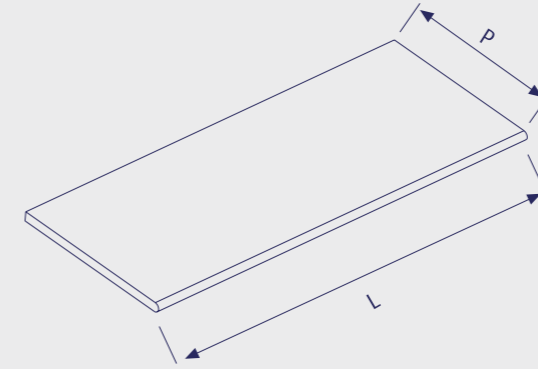

STORE
SYSTEMS
MAĞAZA
SİSTEMLERİ

WOODEN SHELF
AĞSAP RAF

Code / Kod	P	H	L	Description / Açıklama
5G00000001M	500		1000	18 mm MDF
5G00000002M	500		900	
5G00000003M	500		700	
5G00000004M	400		1000	
5G00000005M	400		900	
5G00000006M	400		700	
5G00000007M	300		1000	
5G00000008M	300		900	
5G00000009M	300		700	
5G00000010M	500		1000	30 mm SNT
5G00000011M	500		900	
5G00000012M	500		700	
5G00000013M	400		1000	
5G00000014M	400		900	
5G00000015M	400		700	
5G00000016M	300		1000	
5G00000017M	300		900	
5G00000018M	300		700	

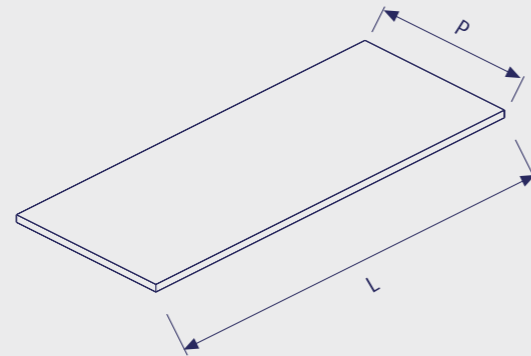

A

**BEVERAGES &
WINE UNITS**

**İÇECEKLER &
ŞARAP REYONLARI**

09

PINE WOODEN WALL UNIT
PINE AHŞAP DUVAR ÜNİTESİ



**BEVERAGES &
WINE UNITS**
İÇECEKLER &
ŞARAP REYONLARI

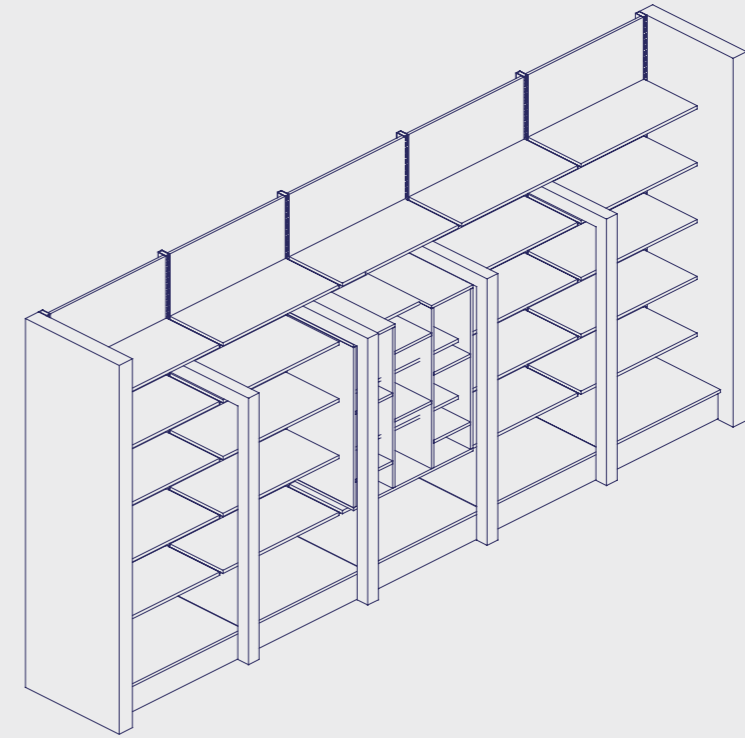
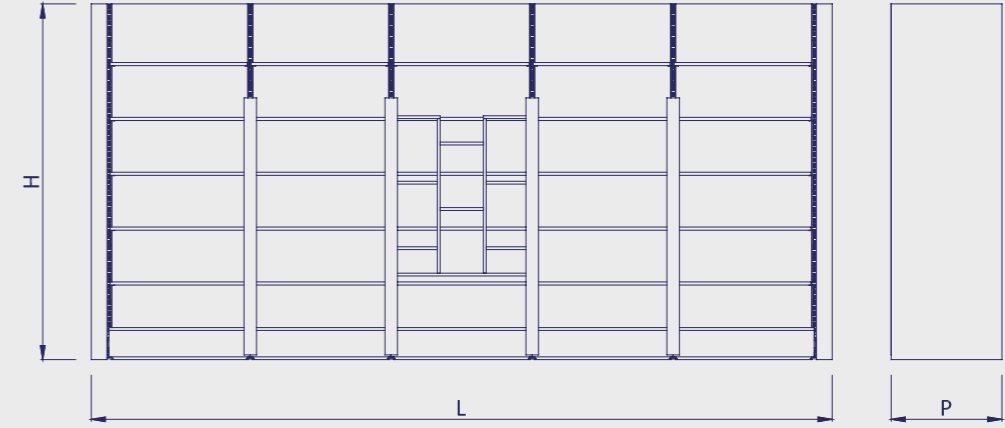

Code / Kod	P	H	L	Description / Açıklama
21A0000015U	600	2270	4500	



**BEVERAGES &
WINE UNITS**
İÇECEKLER &
ŞARAP REYONLARI

BIRCH WOODEN WALL UNIT
BIRCH AHŞAP DUVAR ÜNİTESİ

Code / Kod	P	H	L	Description / Açıklama
21A0000002U	600	2700	2480	

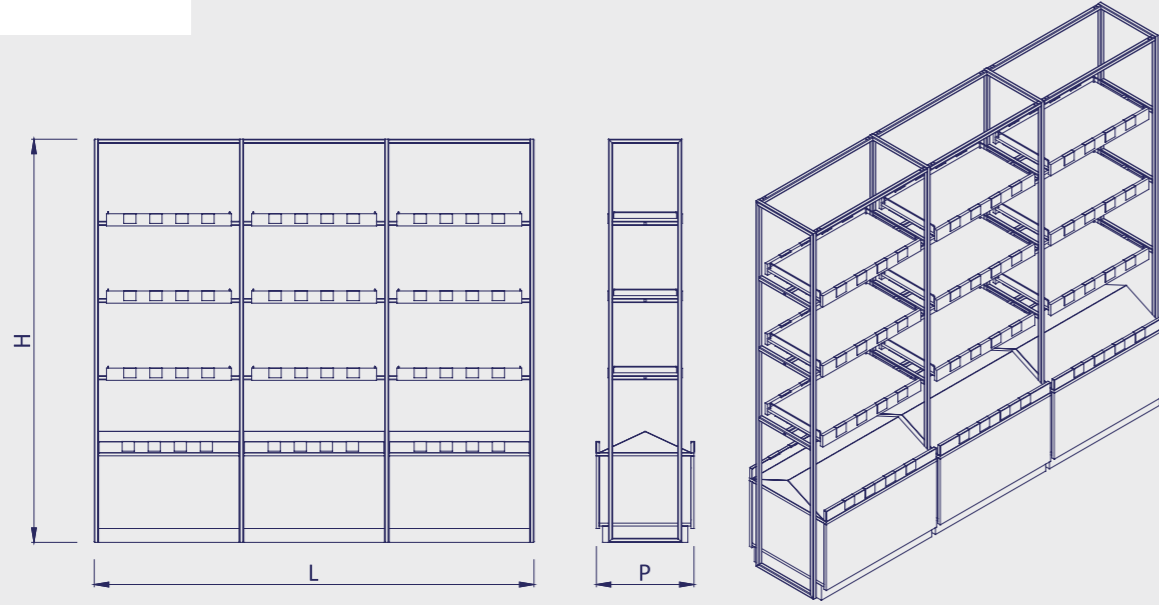

H

L

P

CHERRY WOODEN WALL UNIT
CHERRY AHŞAP DUVAR ÜNİTESİ

Code / Kod	P	H	L	Description / Açıklama
21A0000003U	500	2060	700	
21A0000004U	500	2060	900	
21A0000005U	500	2060	1000	
21A0000006U	500	2270	700	
21A0000007U	500	2270	900	
21A0000008U	500	2270	1000	

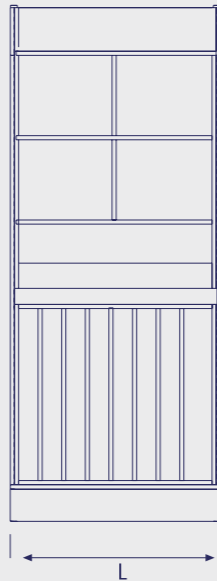
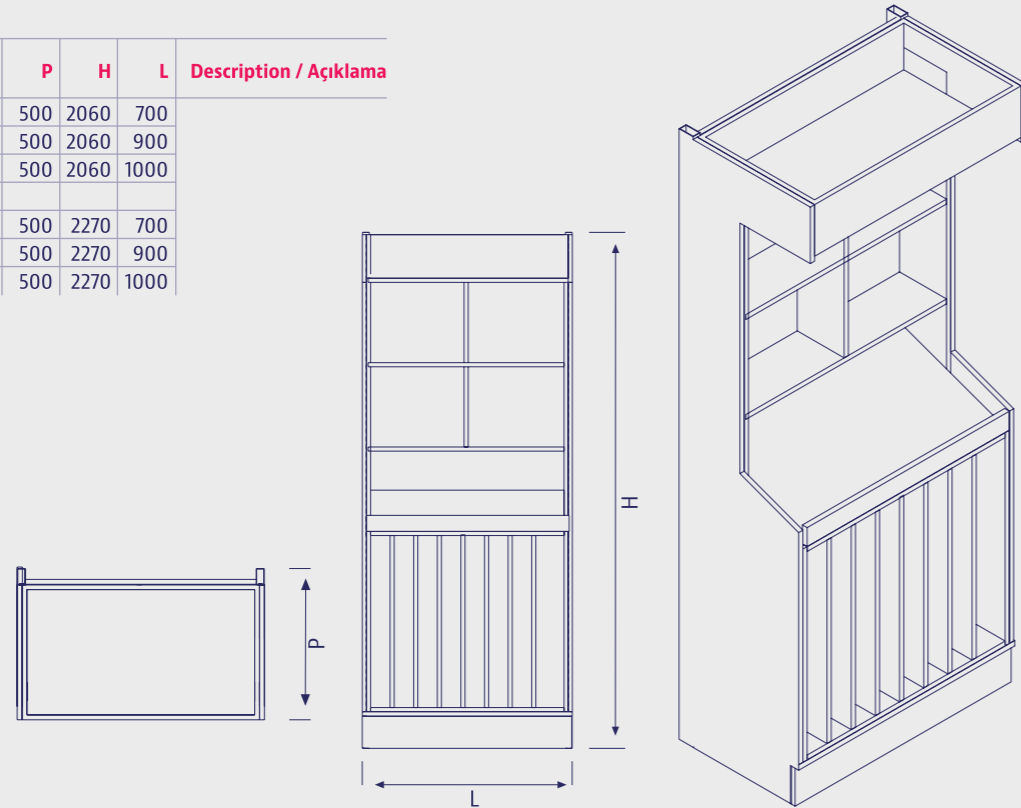

H

L

P

MAPLE WALL UNIT
MAPLE DUVAR ÜNİTESİ

Code / Kod	P	H	L	Description / Açıklama
21A0000009U	350	1700	1975	



H

650

650

650

L

P



**BEVERAGES &
WINE UNITS**
İÇECEKLER &
ŞARAP REYONLARI

MAPLE WALL UNIT
MAPLE DUVAR ÜNİTESİ (ŞAPKALI)

Code / Kod	P	H	L	Description / Açıklama
21A0000010U	300	2480	1600	



H

63

63

63

L

P



BEVERAGES &
WINE UNITS
İÇECEKLER &
ŞARAP REYONLARI

CEDAR WOODEN WALL UNIT
CEDAR AHŞAP DUVAR ÜNİTESİ

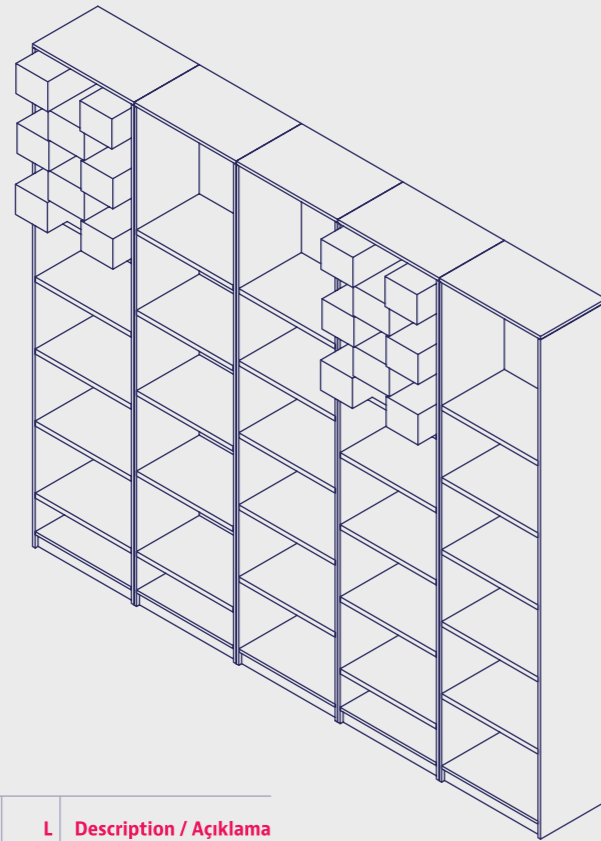
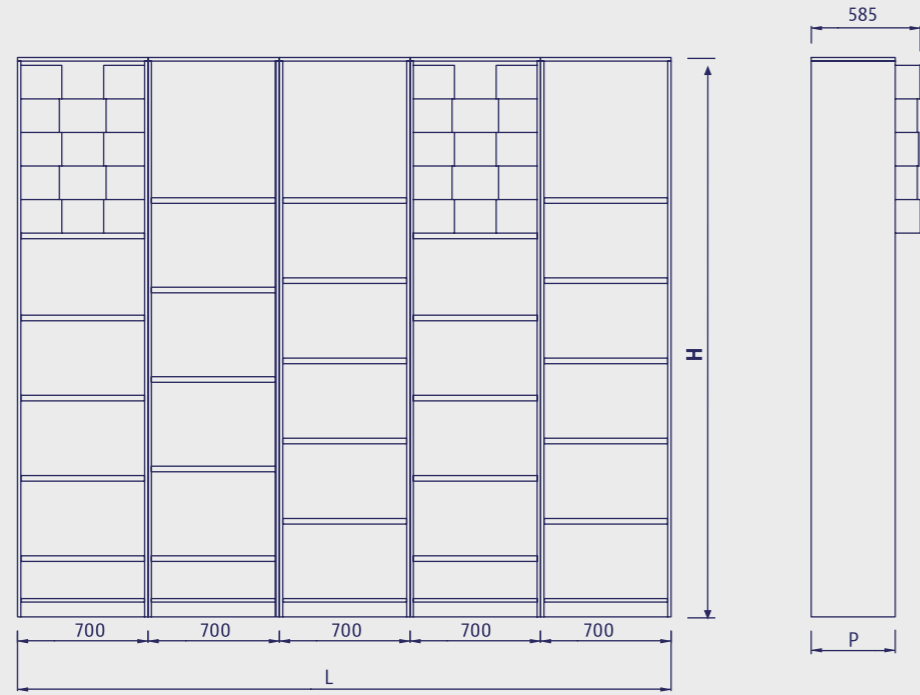

Code / Kod	P	H	L	Description / Açıklama
21A000011U	450	2270	3500	



BEVERAGES &
WINE UNITS
İÇECEKLER &
ŞARAP REYONLARI

CEDAR WOODEN DISPLAY UNIT
CEDAR AHŞAP ORTA STAND

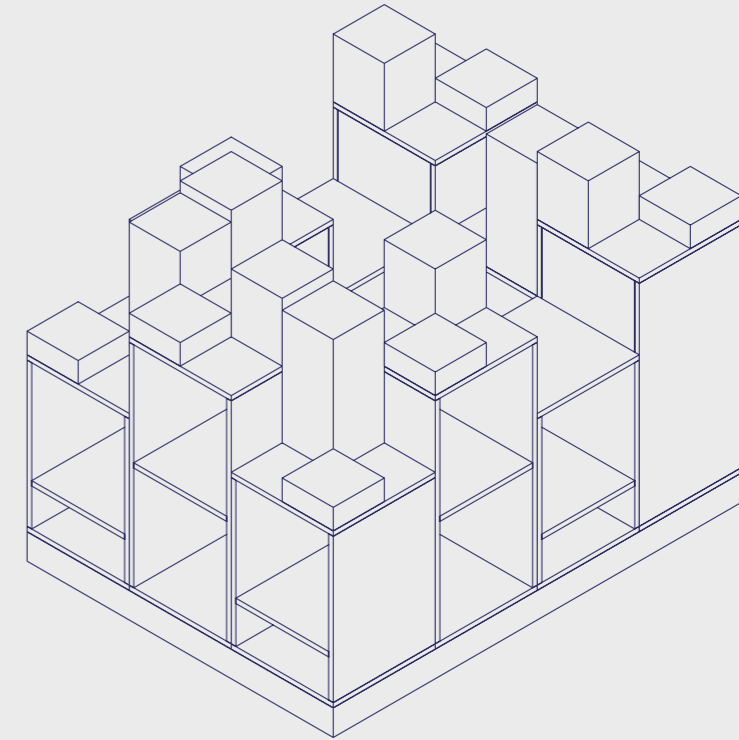
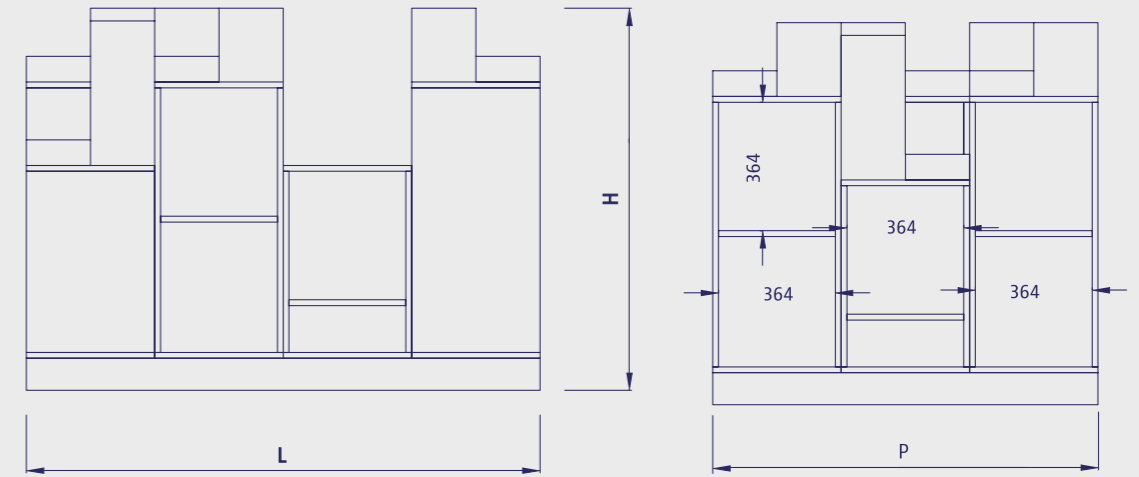

Code / Kod	P	H	L	Description / Açıklama
21A000012U	1200	1200	1600	



BEVERAGES &
WINE UNITS
İÇECEKLER &
ŞARAP REYONLARI

WALNUT WOODEN WALL UNIT
WALNUT AHŞAP DUVAR ÜNİTE

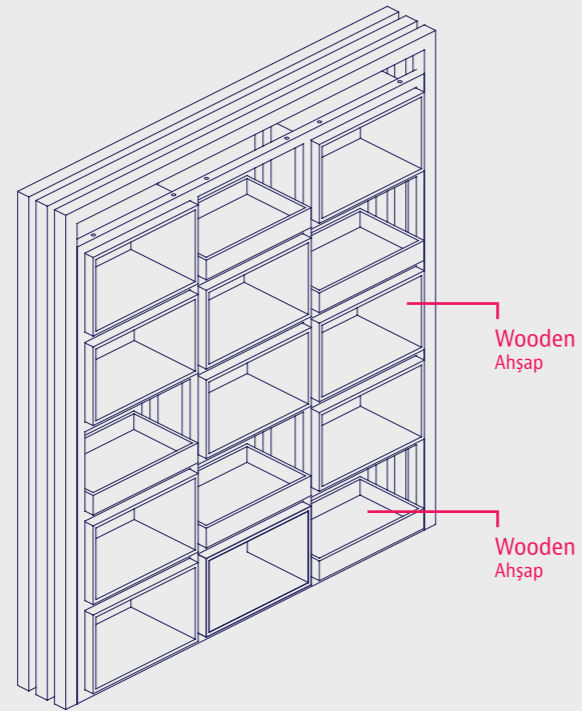
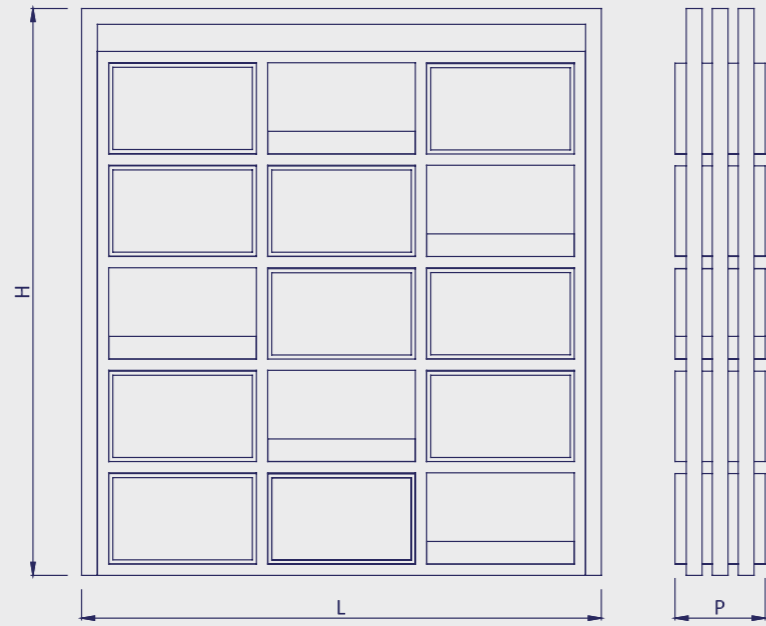

Code / Kod	P	H	L	Description / Açıklama
21A0000013U	450	2270	3500	



BEVERAGES &
WINE UNITS
İÇECEKLER &
ŞARAP REYONLARI

ASH MIDDLE STAND
ASH YUVARLAK STAND

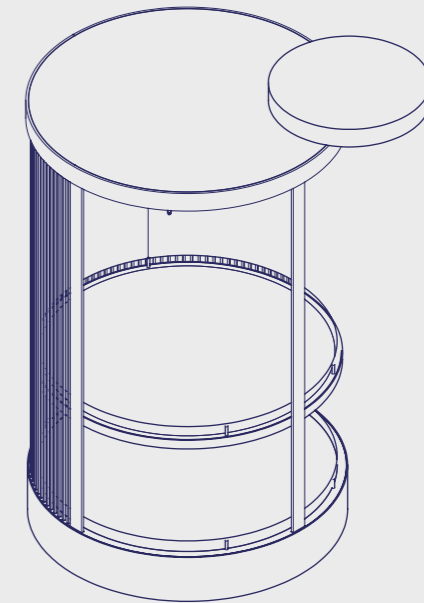
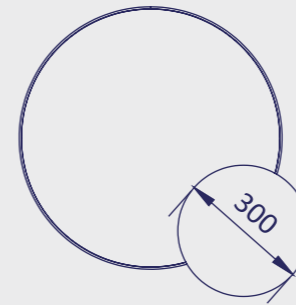
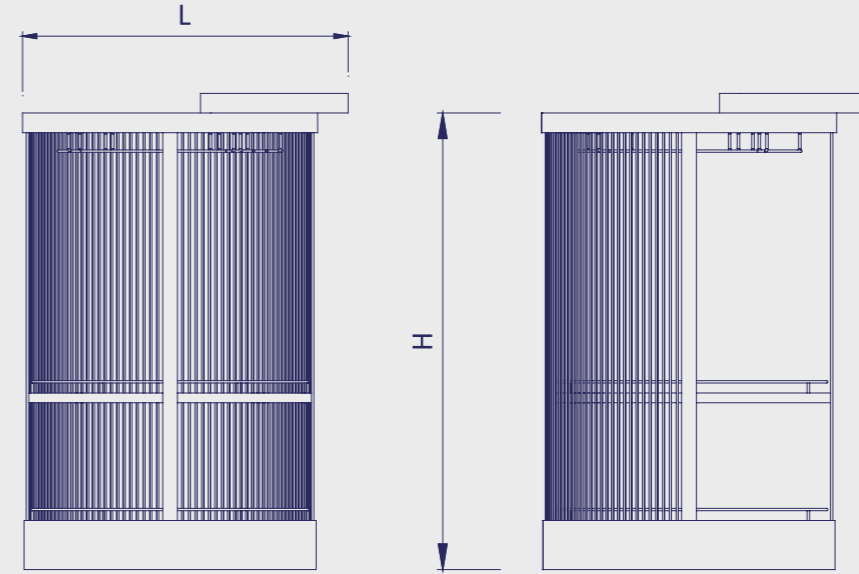

Code / Kod	P	H	L	Description / Açıklama
21A0000014U	662	970	662	



BEVERAGES &
WINE UNITS
İÇECEKLER &
ŞARAP REYONLARI

MINT WALL SECTION
MİNT DUVAR REYONU

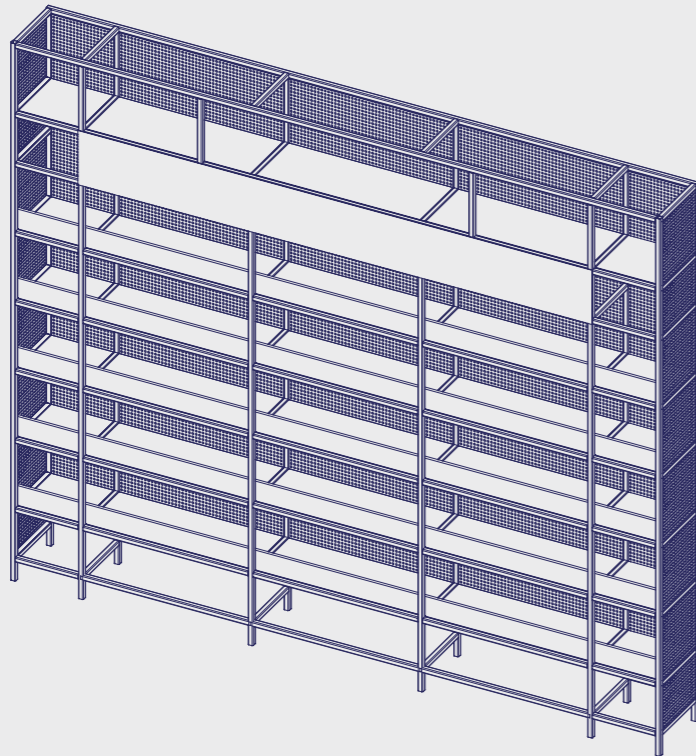
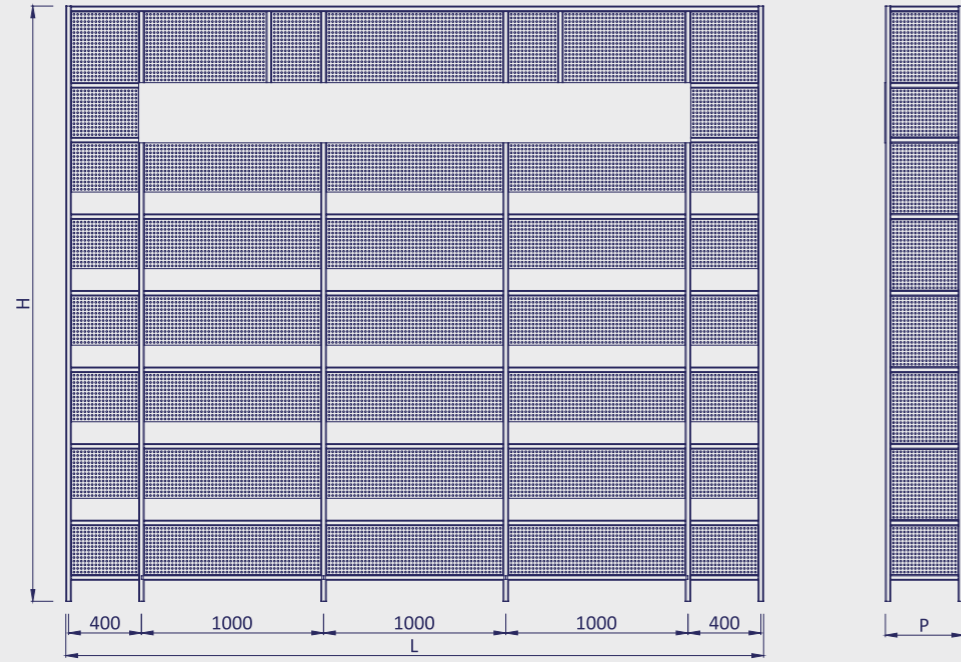

Code / Kod	P	H	L	Description / Açıklama
22A0000026U	430	3265	400	
22A0000025U	430	3265	1000	

09

B

COSMETICS
PARFÜMERİ



COSMETICS
PARFÜMERİ

FRAME FOR GLASS SHELF CAM RAF İSKELETİ

Code / Kod	P	H	L	Description / Açıklama
6D0000001B	200	500		With single support Tek destekli
6D0000002B	200	700		
6D0000003B	200	900		
6D0000004B	200	1000		
6D0000005B	200	1250		
6D0000006B	300	500		With single support Tek destekli
6D0000007B	300	700		
6D0000008B	300	900		
6D0000009B	300	1000		
6D0000010B	300	1250		

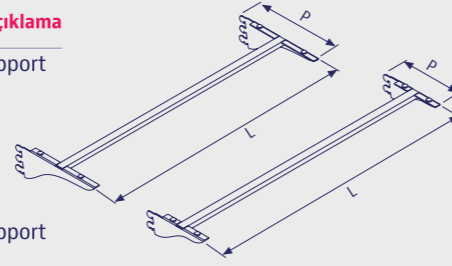

FRAME FOR GLASS SHELF CAM RAF İSKELETİ

Code / Kod	P	H	L	Description / Açıklama
6D0000011B	400	500		With double support Çift destekli
6D0000012B	400	700		
6D0000013B	400	900		
6D0000014B	400	1000		
6D0000015B	400	1250		
6D0000016B	500	500		With double support Çift destekli
6D0000017B	500	700		
6D0000018B	500	900		
6D0000019B	500	1000		
6D0000020B	500	1250		

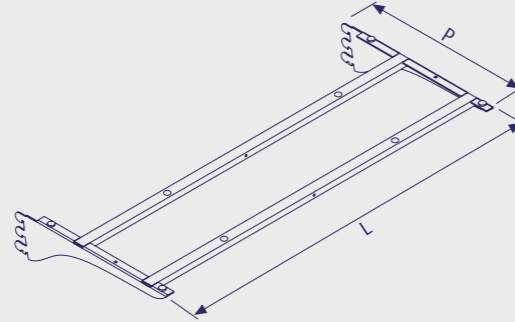

FRAME FOR GLASS SHELF (SUITABLE FOR LIGHTING & STANDARD LABEL HOLDER) CAM RAF İSKELETİ (AYDINLATMA VE STANDART RAF ETİKETLİĞİ TAKILMAYA UYGUN)

Code / Kod	P	H	L	Description / Açıklama
6E0000006U	300	500		
6E0000007U	300	700		
6E0000008U	300	900		
6E0000009U	300	1000		
6E0000010U	300	1250		
6E0000011U	400	500		
6E0000012U	400	700		
6E0000013U	400	900		
6E0000014U	400	1000		
6E0000015U	400	1250		
6E0000016U	500	500		
6E0000017U	500	700		
6E0000018U	500	900		
6E0000019U	500	1000		
6E0000020U	500	1250		

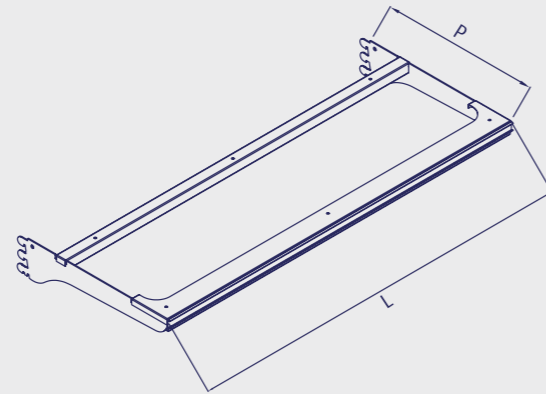

GLASS SHELF (STRAIGHT) 6 mm CAM RAF (DÜZ) mm

Code / Kod	P	H	L	Description / Açıklama
5F0000001T	200	500		Glass shelf can be transparent or frosted Cam Raf lar şeffaf ya da kumlu olabilir.
5F0000002T	200	700		
5F0000003T	200	900		
5F0000004T	200	1000		
5F0000005T	300	500		
5F0000006T	300	700		
5F0000007T	300	900		
5F0000008T	300	1000		
5F0000009T	400	500		
5F0000010T	400	700		
5F0000011T	400	900		
5F0000012T	400	1000		
5F0000013T	500	500		
5F0000014T	500	700		
5F0000015T	500	900		
5F0000016T	500	1000		

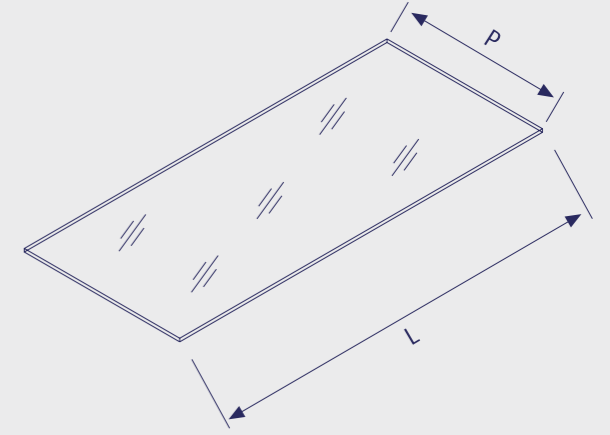

GLASS SHELF (STRAIGHT) 8 mm CAM RAF (DÜZ) mm

Code / Kod	P	H	L	Description / Açıklama
5F0000033T	200	500		Glass shelf can be transparent or frosted Cam Raf lar şeffaf ya da kumlu olabilir.
5F0000034T	200	700		
5F0000035T	200	900		
5F0000036T	200	1000		
5F0000037T	300	500		
5F0000038T	300	700		
5F0000039T	300	900		
5F0000040T	300	1000		
5F0000041T	400	500		
5F0000042T	400	700		
5F0000043T	400	900		
5F0000044T	400	1000		
5F0000045T	500	500		
5F0000046T	500	700		
5F0000047T	500	900		
5F0000048T	500	1000		

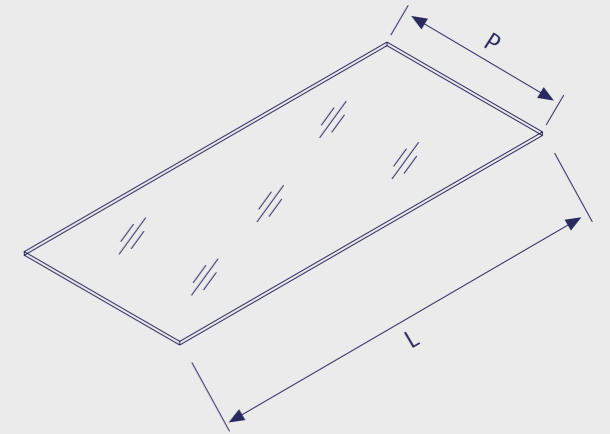



COSMETICS
PARFÜMERİ

GLASS & PLEXY BACK PANEL HOLDER CAM & PLEKSİ ARKA PANO TUTUCU

Code / Kod	P	H	L	Description / Açıklama
19C000001B			500	Alt
19C000003B			700	
19C000007B			900	
19C000009B			1000	
19C000021B			1250	
19C000002B			500	Üst
19C000004B			700	
19C000008B			900	
19C000010B			1000	
19C000022B			1250	

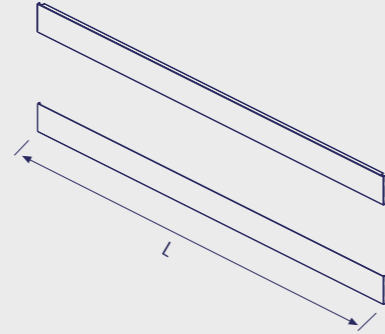

GLASS BACK PANEL 4 MM CAM ARKA PANO 4 MM

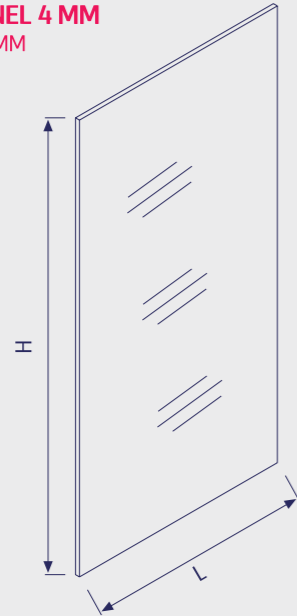

Code / Kod	P	H	L	Description / Açıklama
4S0000033T		1430	700	Can be transparent or frosted Şeffaf ya da kumlu olabilir.
4S0000002T		1430	900	
4S0000003T		1430	1000	
4S0000004T		1640	700	
4S0000005T		1640	900	
4S0000006T		1640	1000	
4S0000007T		1850	700	
4S0000008T		1850	900	
4S0000009T		1850	1000	
4S0000010T		2060	700	
4S0000011T		2060	900	
4S0000012T		2060	1000	
4S0000013T		2270	700	
4S0000014T		2270	900	
4S0000015T		2270	1000	

PLEXY BACK PANEL 4 mm PLEKSİ ARKA PANO 4 mm

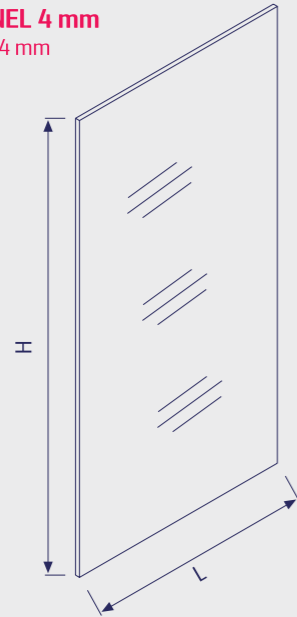

Code / Kod	P	H	L	Description / Açıklama
4T0000002T		1430	700	Colour alternatives are possible Renk alternatifleri mevcuttur.
4T0000004T		1430	900	
4T0000005T		1430	1000	
4T0000012T		1640	700	
4T0000014T		1640	900	
4T0000015T		1640	1000	
4T0000017T		1850	700	
4T0000019T		1850	900	
4T0000020T		1850	1000	
4T0000022T		2060	700	
4T0000024T		2060	900	
4T0000025T		2060	1000	
4T0000007T		2270	700	
4T0000009T		2270	900	
4T0000010T		2270	1000	

DECORATIVE WOODEN HEAD UNIT FOR COSMETICS KOZMETİK AHŞAP GONDOLBAŞI

Code / Kod	P	H	L	Description / Açıklama
20A0000007U	200	1430	1100	

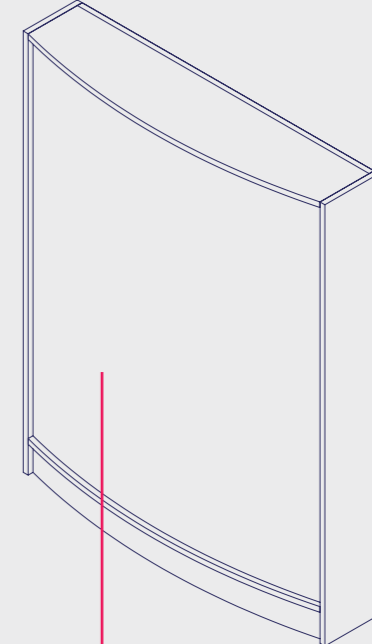
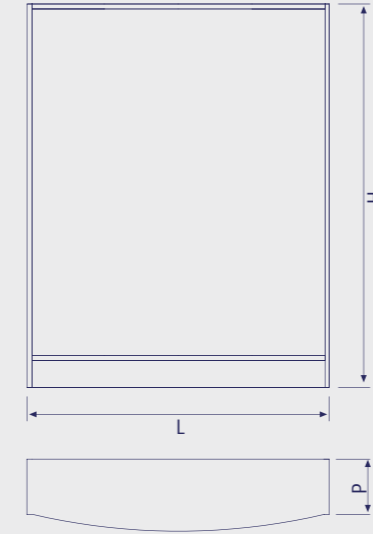

Advertisement
Dijital Görsel

DECORATIVE SIDE WALL METAL WITH LIGHTING DEKORATİF YAN DUVAR

Code / Kod	P	H	L	Description / Açıklama
20A0000003U	150	1640	400	
20A0000005U	150	1850	400	

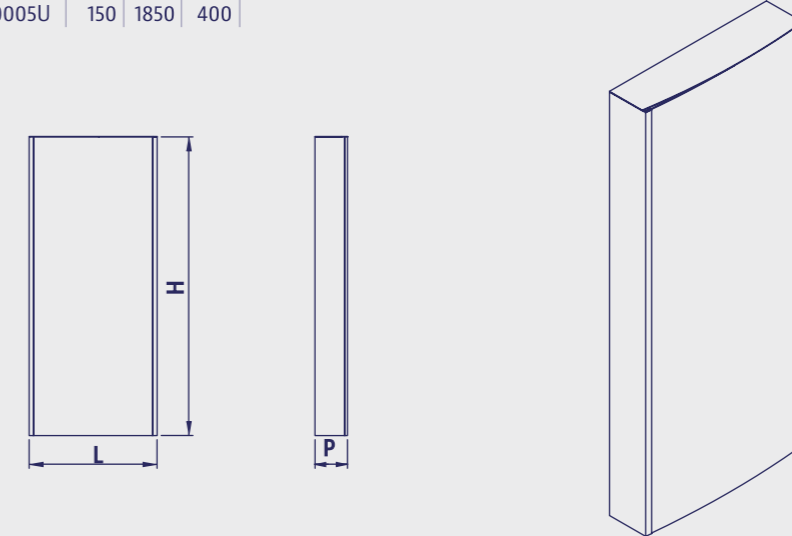

COSMETICS
PARFÜMERİ



COSMETICS
PARFÜMERİ

PATİNA GONDOLA UNIT FOR COSMETICS
PATİNA KOZMETİK ORTA REYON

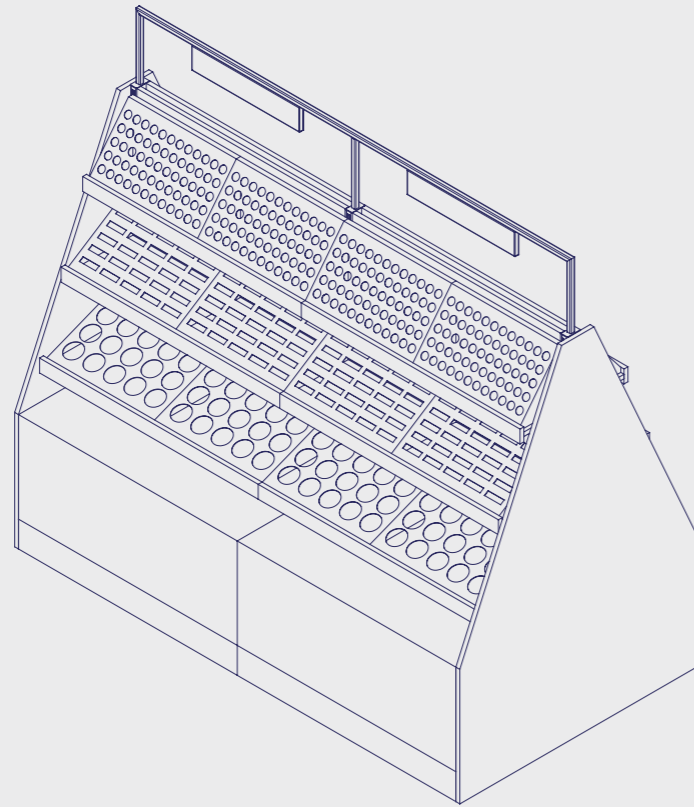
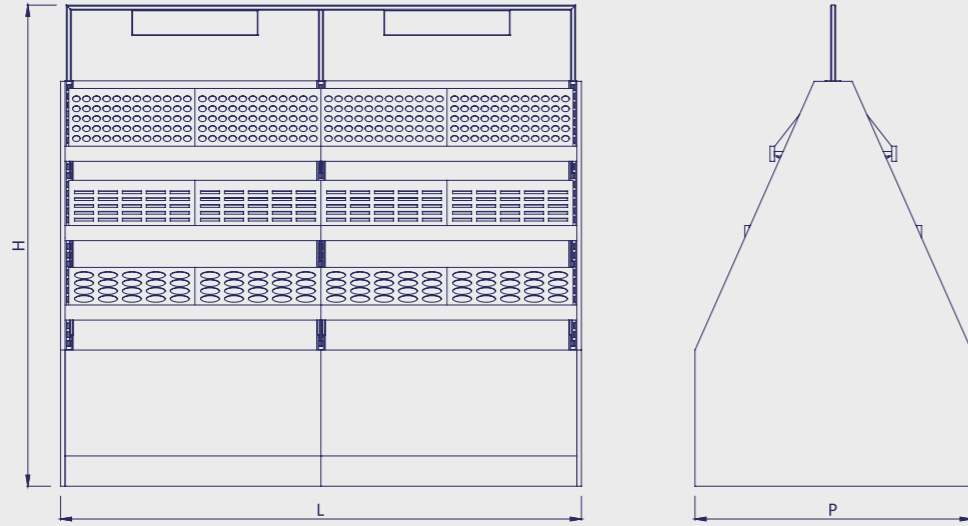

Code / Kod	P	H	L	Description / Açıklama
20A0000008U	1096	1905	2066	



COSMETICS
PARFÜMERİ

COSMETICS "C" STAND
KOZMETİK C STAND

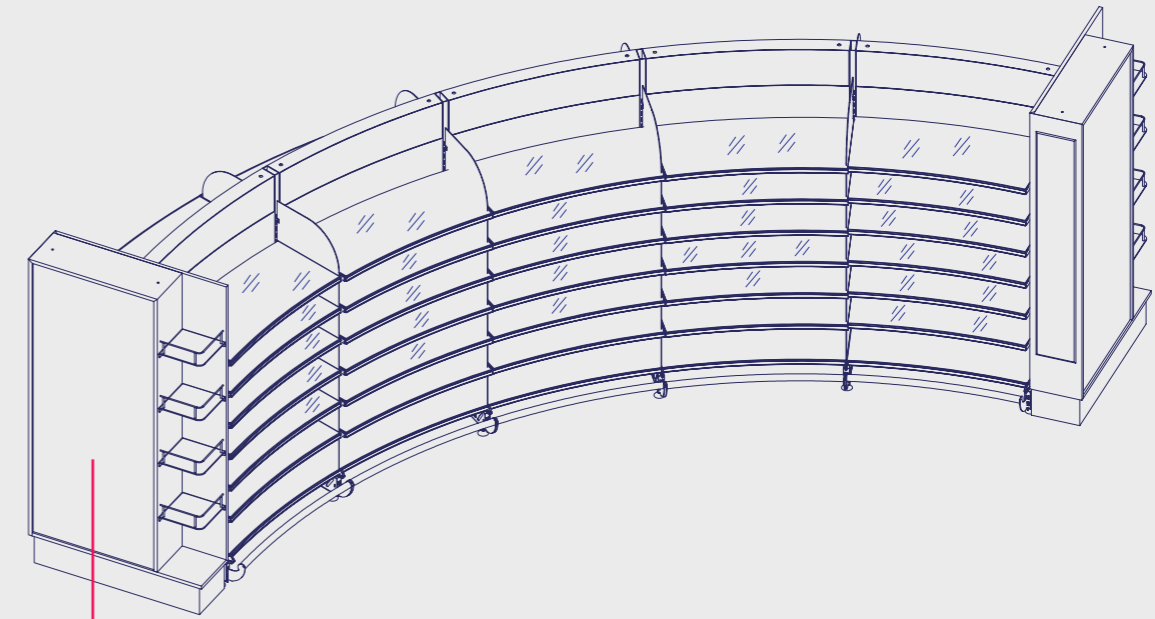
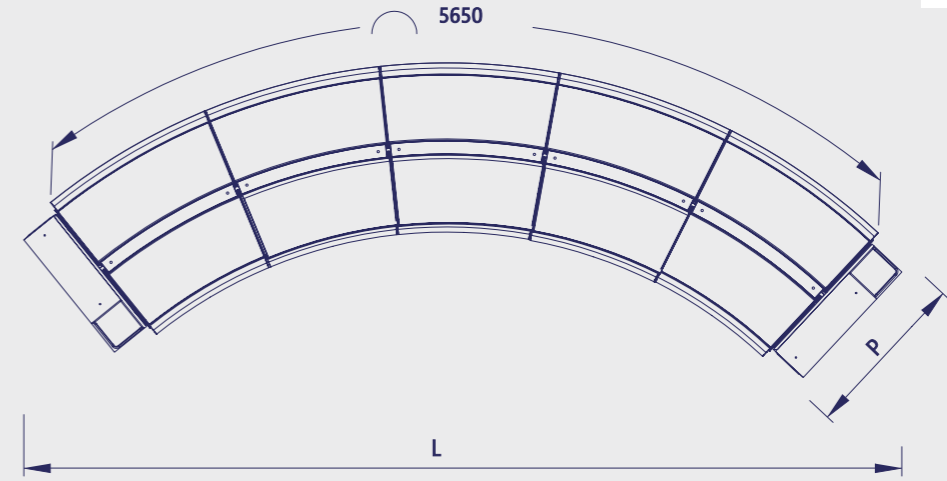

Wooden Gondola Head
Ahşap Gondolbaşı Ünitesi

Code / Kod	P	H	L	Description / Açıklama
20B0000001U	400	1640		Kozmetik C Stand
20B0000002U	400	1640		Kozmetik C stand Bitiş
20B0000003U	255	1640		Kozmetik C stand Gondolbaşı

Plexy back panel with
illumination, glass shelves
Aydınlatmalı pleksi,
arka pano, cam raf



COSMETICS
PARFÜMERİ

AZUR WOODEN WALL UNIT
AZUR AĖŞAP DUVAR REYONU

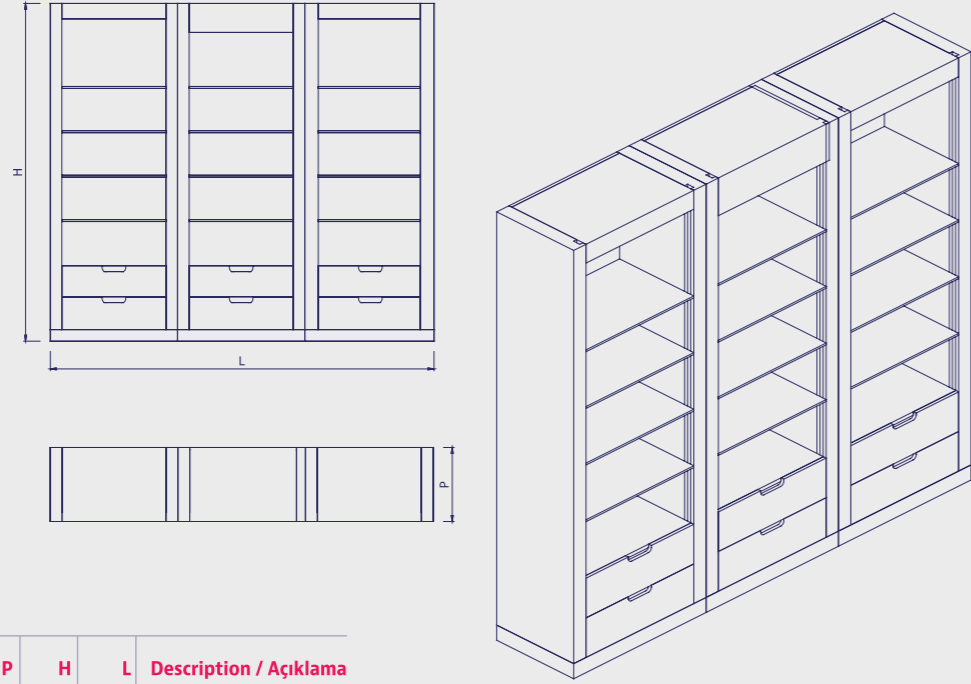

Code / Kod	P	H	L	Description / Açıklama
20A0000010U	500	2270	2700	

HIMMEL METAL WALL UNIT FOR COSMETICS
HİMMEL KOZMETİK DUVAR REYONU

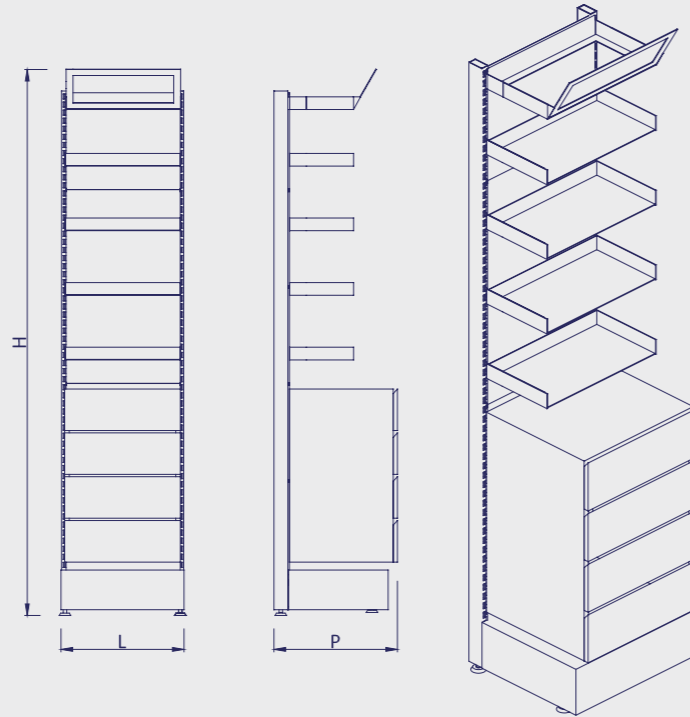

Code / Kod	P	H	L	Description / Açıklama
20A0000011U	550	2400	500	

RUBİN WALL UNIT
RUBİN DUVAR REYONU

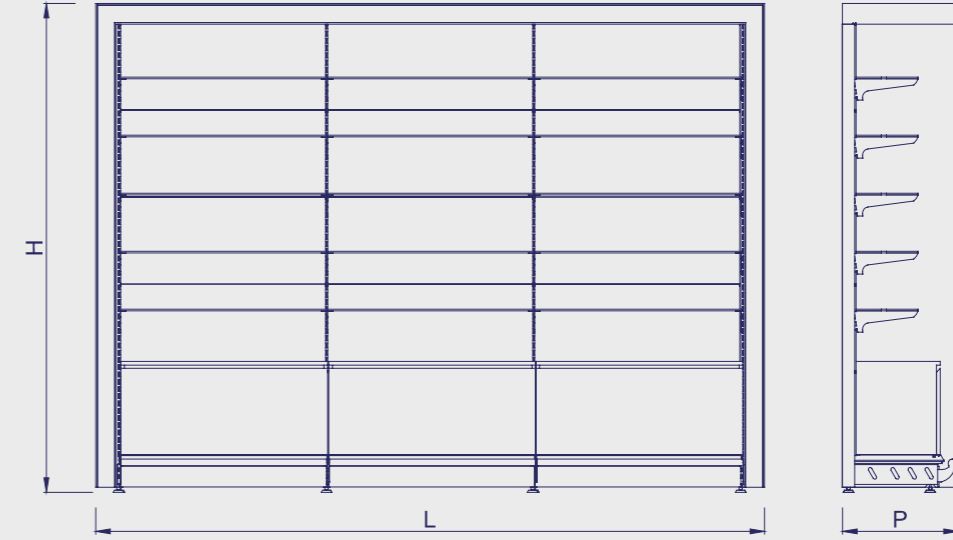

Code / Kod	P	H	L	Description / Açıklama
20A0000012U	560	2270	3230	

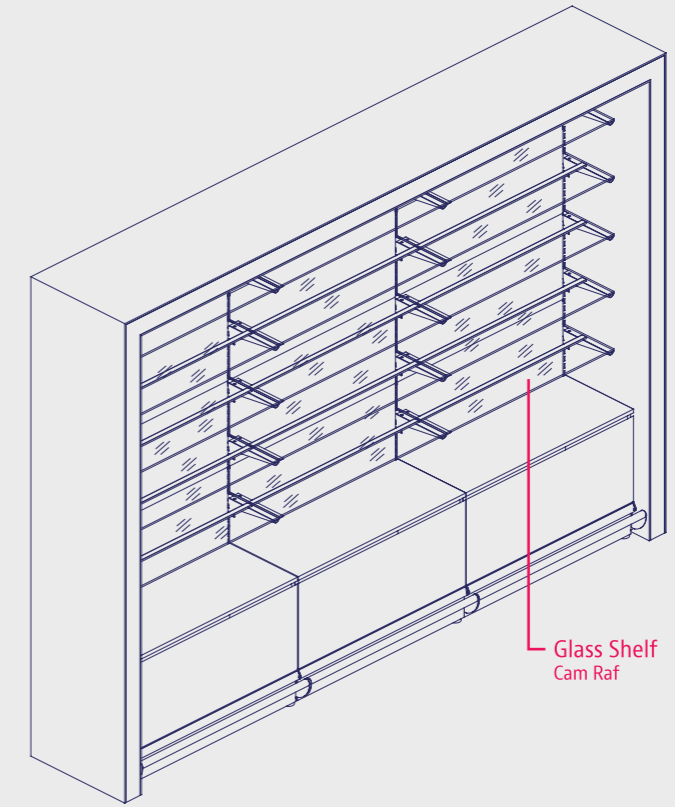

Glass Shelf
Cam Raf



COSMETICS
PARFÜMERİ



COSMETICS
PARFÜMERİ

KORAL WOODEN WALL UNIT
KORAL AHŞAP DUVAR REYONU

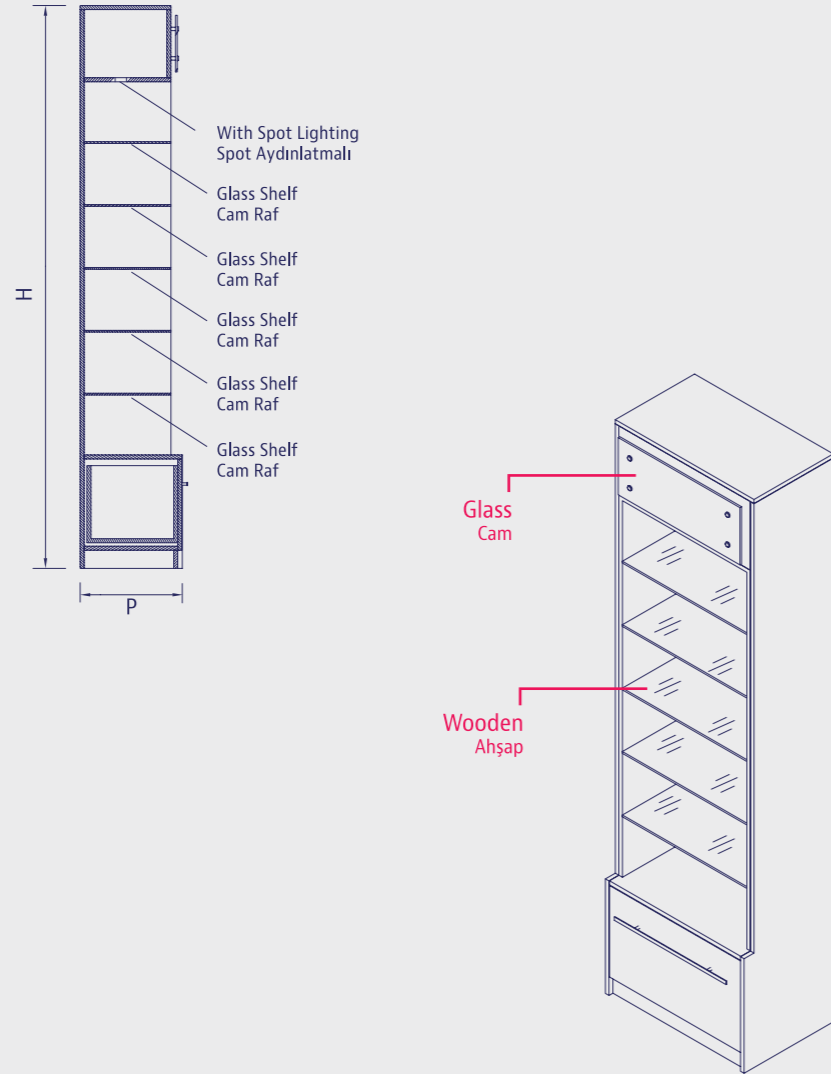

Code / Kod	P	H	L	Description / Açıklama
20A0000013U	450	2270	700	
20A0000014U	450	2270	900	



COSMETICS
PARFÜMERİ

MELON WOODEN WALL UNIT
MELON AHŞAP DUVAR REYONU

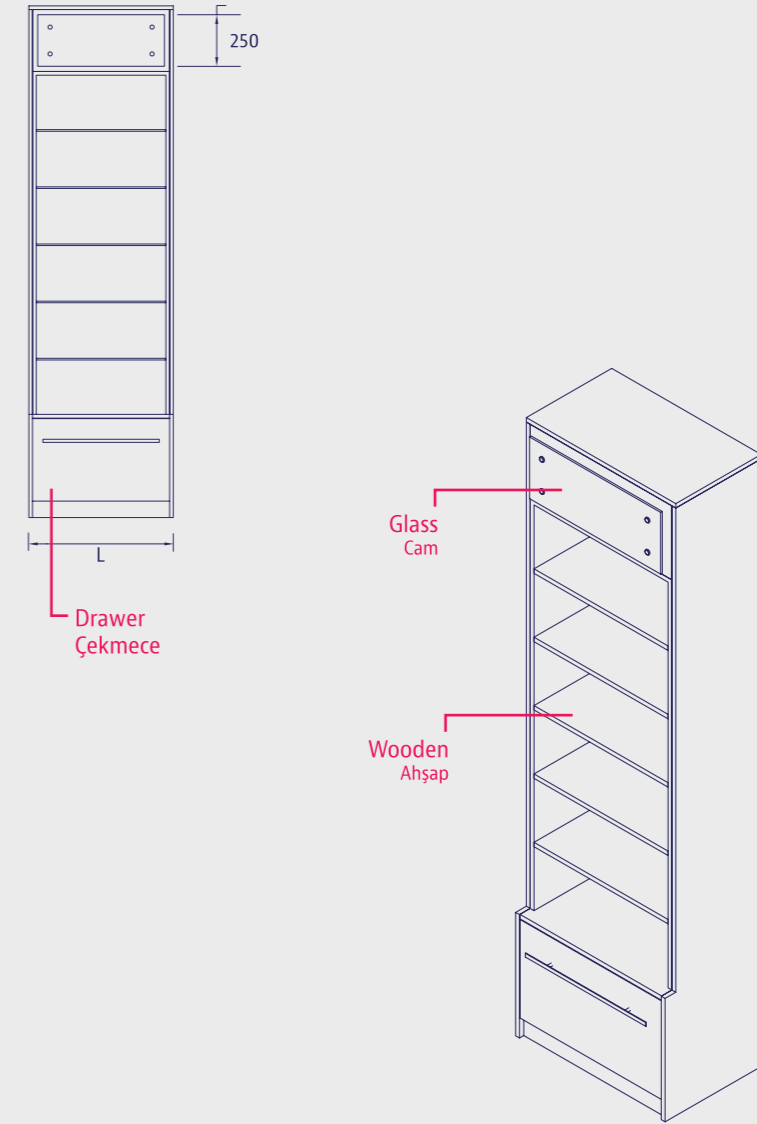

Code / Kod	P	H	L	Description / Açıklama
20A0000015U	450	2270	700	
20A0000016U	450	2270	900	



COSMETICS
PARFÜMERİ

PATİNA WALL UNIT
PATİNA DUVAR REYONU

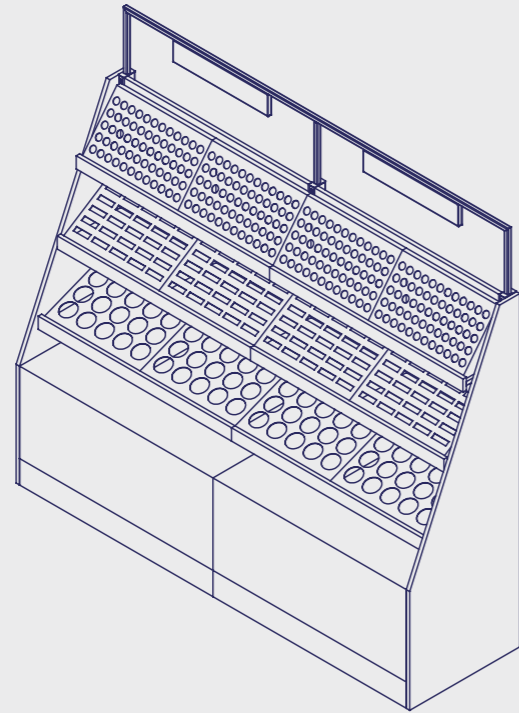
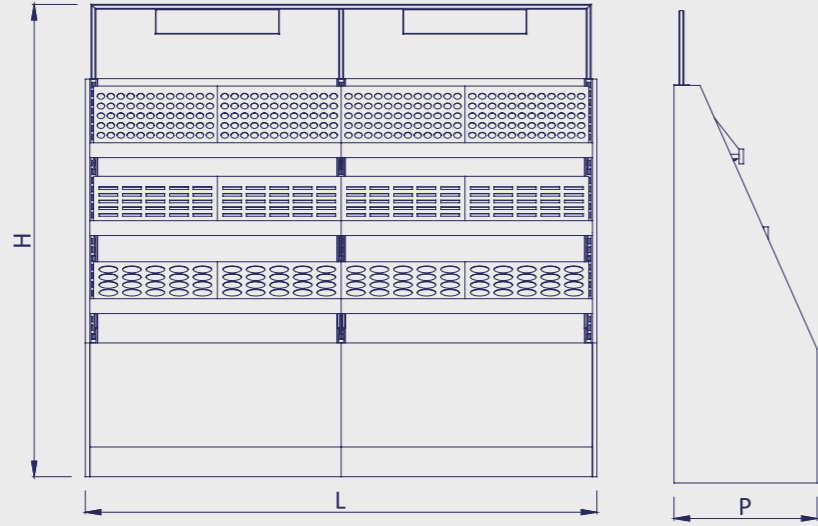

Code / Kod	P	H	L	Description / Açıklama
20A0000009U	578	1905	2066	

COSMETICS WALL UNIT
KOZMETİK DUVAR REYONU

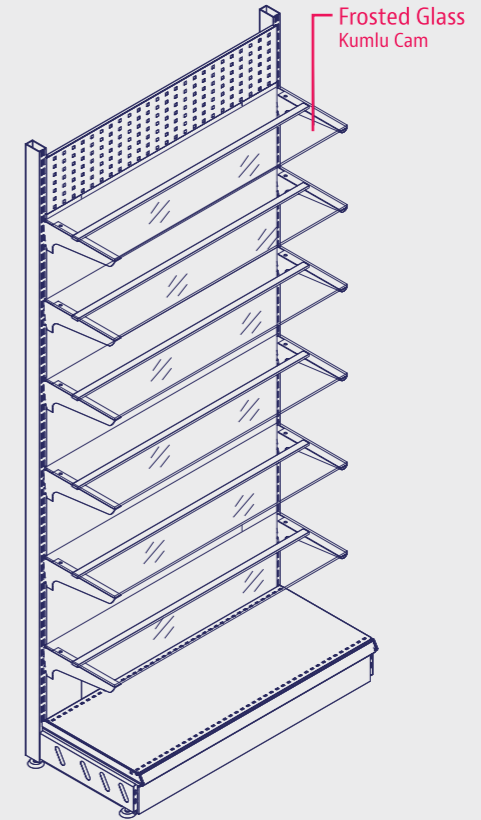
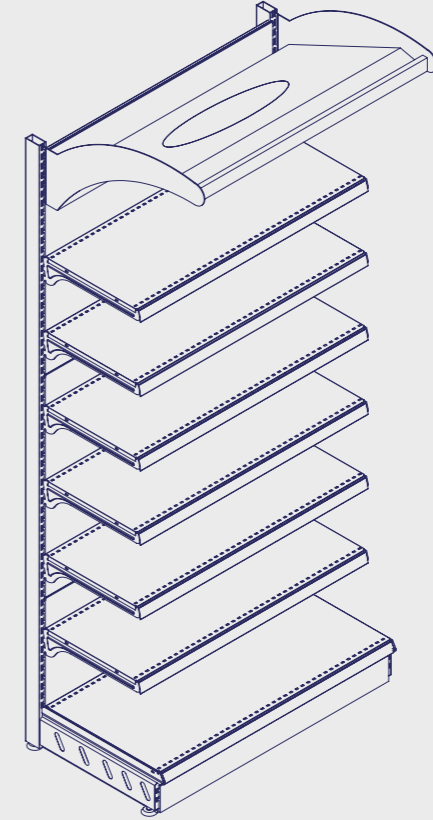

COSMETICS
PARFÜMERİ



COSMETICS
PARFÜMERİ

■ GONDOLA UNIT FOR COSMETICS
KOZMETİK ORTA REYON

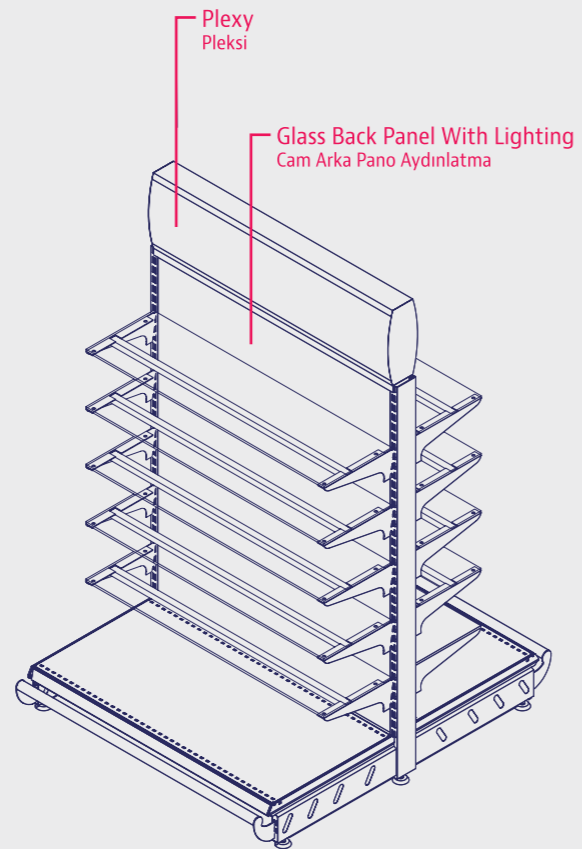
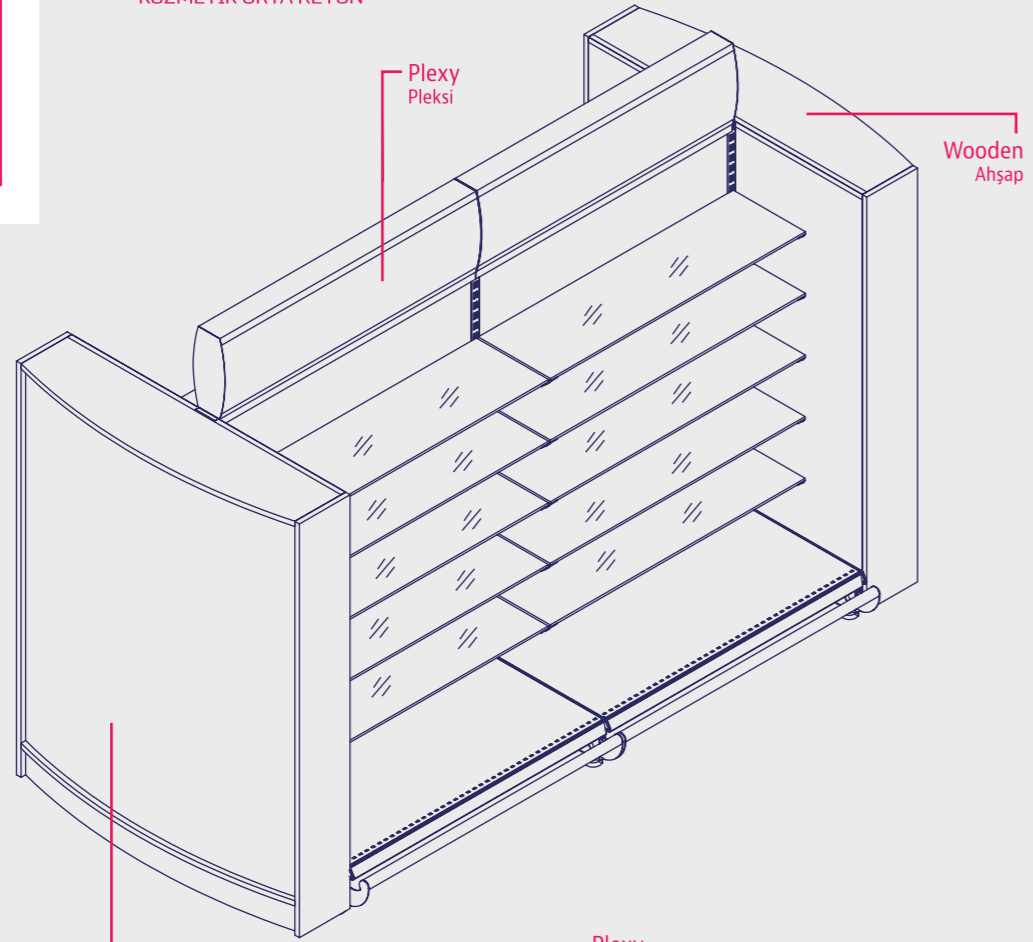

■ GONDOLA UNIT FOR COSMETICS
KOZMETİK ORTA REYON

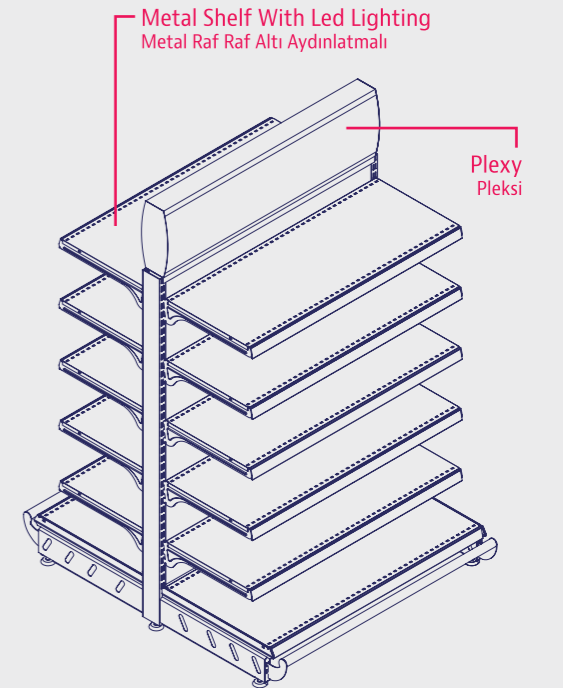
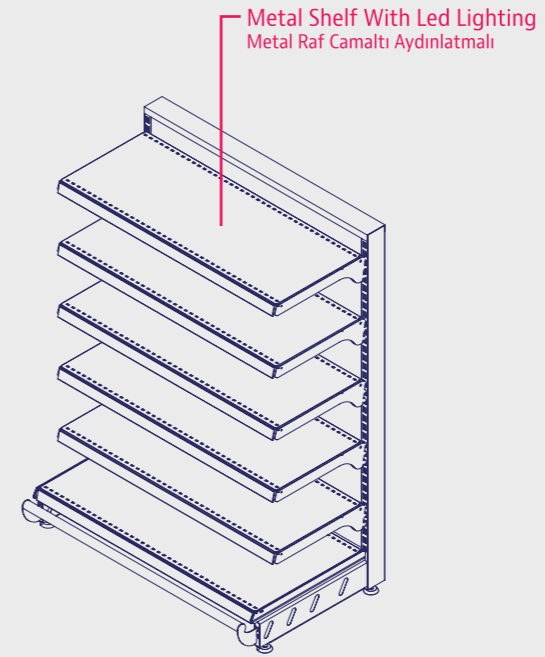
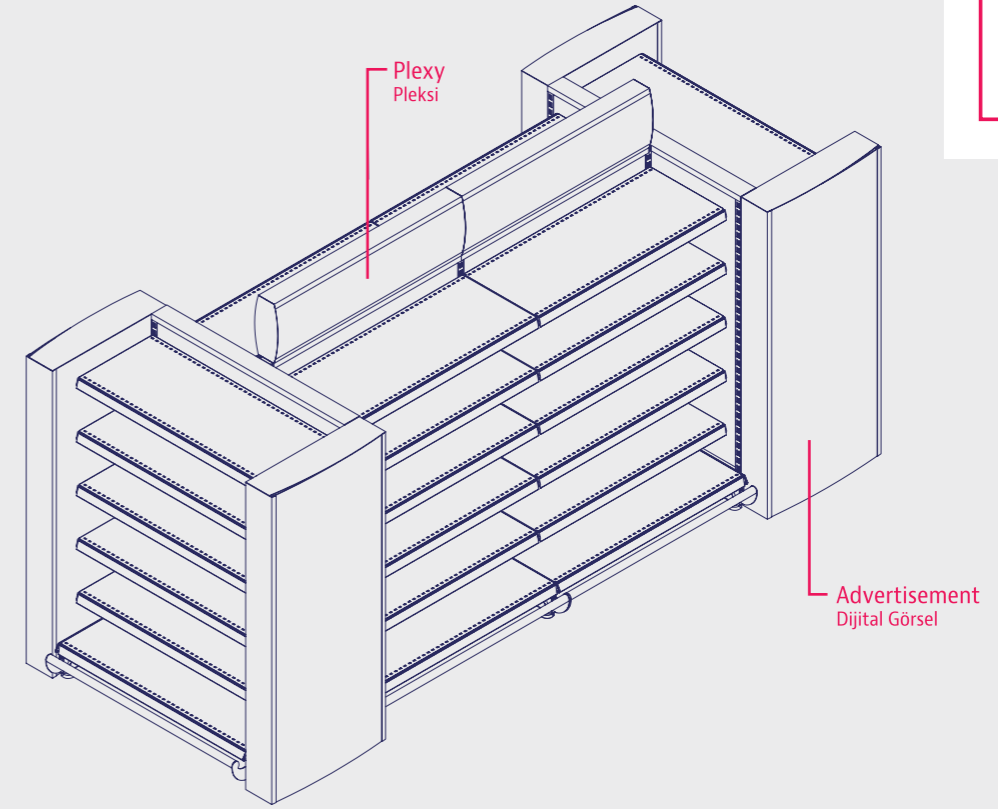

COSMETICS
PARFÜMERİ

C

TEXTILE &
SHOES

TEKSTİL &
AYAKKABI

09

WOODEN UNIT
AĖAP DUVAR ÜNİTESİ

500B L: 1000

Code / Kod	Qnt	P	H	L	Description / Açıklama
3R00000060B	1	450	2270		Welded upright 30x60
4R00000209M					Wooden Back Panel With Inner Aluminum
	1		2270	970	
19D0000007G	6		630		Back Panel Holder Bracket
5G00000046M	1	500	160	900	Wooden Base Shelf
5G00000005M	1	400		900	Wooden Shelf
5G00000201M	2	400		500	Wooden Shelf
6B00000028B	6	350			Bracket For Wooden Shelf
11D0000020N	1			495	"U" Shape Holder

Code / Kod	Qnt	P	H	L	Description / Açıklama
3R00000060B	1	450	2270		Welded upright 30x60

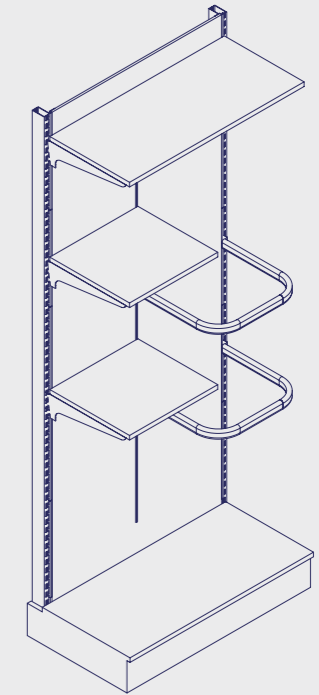
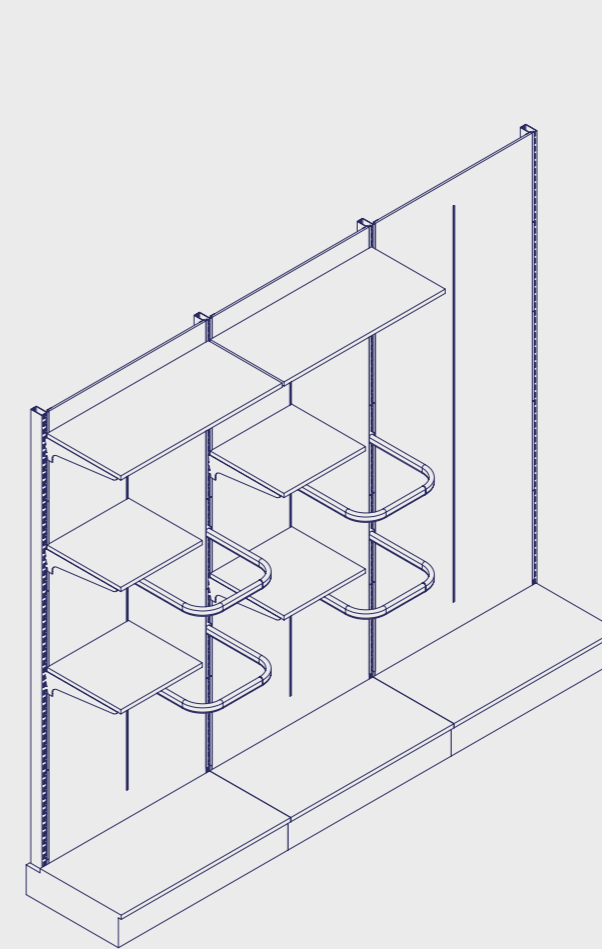

TEXTILE &
SHOES
TEKSTİL &
AYAKKABI



TEXTILE &
SHOES
TEKSTİL &
AYAKKABI

WALL FIXING SYSTEMS
DUVARA MONTE SİSTEMLERİ

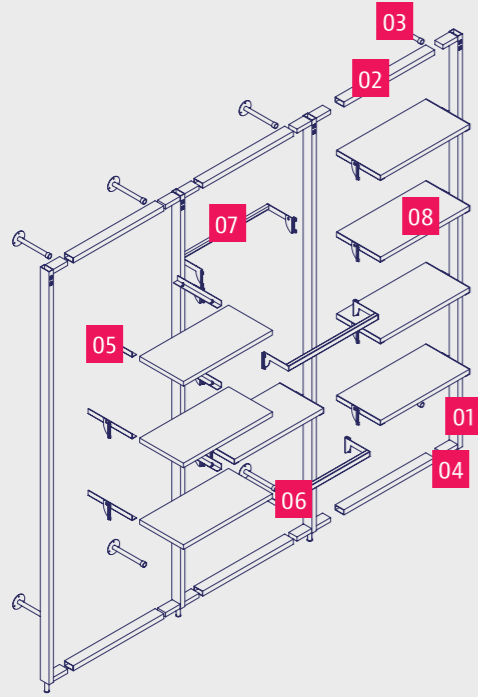

01
Wall Fixing System Upright Right / Left
Dikme 30x60 mm Sağ / Sol

02
Wall Fixing System Fixing Beam
Ara Bağlantı Profili

03
Wall Fixing Beam
Duvara Bağlantı Aparatı

04
Adjustable Screw
Ayar Vidası

05
Wall Fixing System Wooden Shelf Holder
Ahşap Raf Yanağı

06
Wall Fixing System "U" Shape Holder
Duvara Monte Sistem "U" Askı Tutucu

07
Wall Fixing System Rear Bar 20x40 Profile
Duvara Monte Sistem Askı Tutucu Profili 20x40

08
Wall Fixing System Wooden Shelf
Ahşap Raf

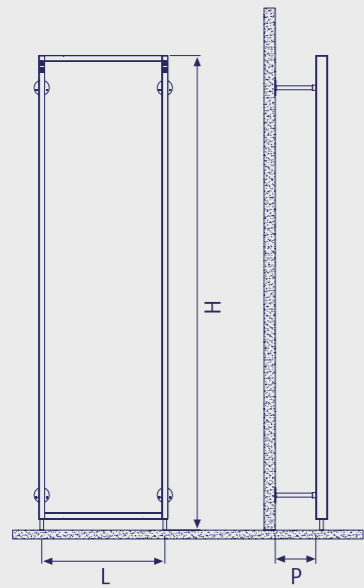

TEXTILE &
SHOES
TEKSTİL &
AYAKKABI

WALL FIXING SYSTEMS
DUVARA MONTE SİSTEMLERİ

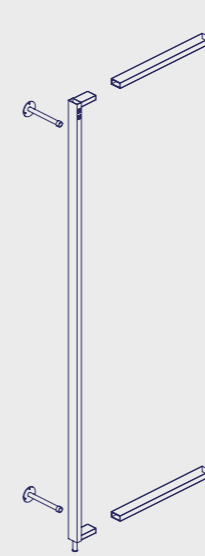

Wall Fixing Systems (Left)
Duvar Monte Sistem (Sol)

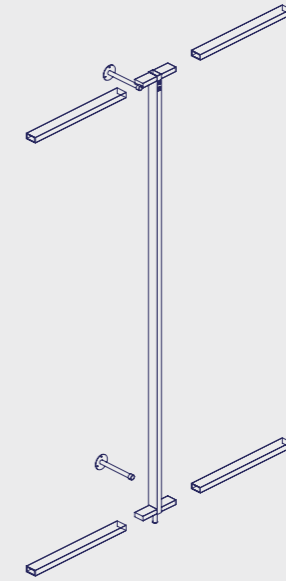

Wall Fixing Systems (Middle)
Duvara Monte Sistem (Orta)



Wall Fixing Systems (Right)
Duvara Monte Sistem (Sağ)

Code / Kod	P	H	L	Description / Açıklama
22A0000001B	210	2500		Left
22A0000002B	210	2500		Middle
22A0000003B	210	2500		Right



**TEXTILE &
SHOES**
TEKSTİL &
AYAKKABI

WALL FIXING SYSTEMS "U" SHAPE HOLDER DUVARA MONTE SİSTEM U ASKI

Code / Kod	P	H	L	Description / Açıklama
22A0000004B	170		650	Chrome coated / Nikel kaplama Zinc Coated / Çinko kaplama

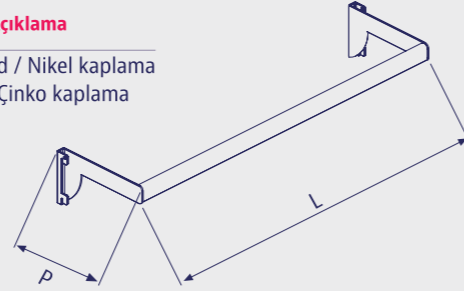

WALL FIXING SYSTEMS REAR BAR 20x40 PROFILE DUVARA MONTE SİSTEM U ASKI PROFİL (20X40)

Code / Kod	P	H	L	Description / Açıklama
22A0000005B	150		650	Chrome coated / Nikel kaplama Zinc Coated / Çinko kaplama

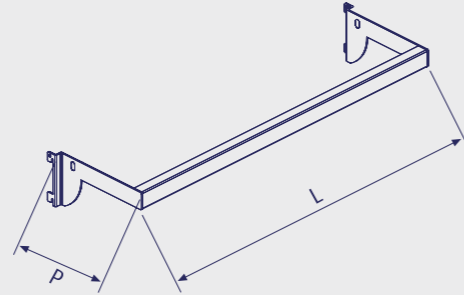

WALL FIXING SYSTEMS WOODEN SHELF HOLDER DUVARA MONTE AHŞAP RAF KONSOL

Code / Kod	P	H	L	Description / Açıklama
6B00000034B	300			Sağ / Right
6B00000036B	300			Sol / Left

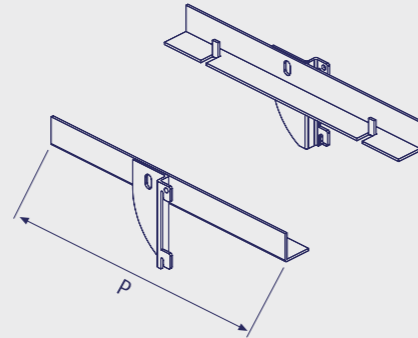

WALL FIXING SYSTEMS WOODEN SHELF DUVARA MONTE SİSTEM AHŞAP RAF

Code / Kod	P	H	L	Description / Açıklama
22A0000006M	400		615	Thickness 30 mm / Kalınlık 30 mm

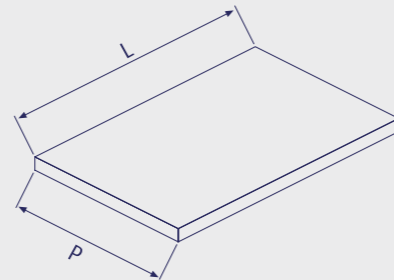

BOUTIQUE SYSTEM UPRIGHT BUTİK SİSTEM PROFİL

Code / Kod	P	H	L	Description / Açıklama
22A0000007B	150	1430		40x40 Box Profile / 40x40
22A0000008B	150	1640		Profil Painted / Boyalı
22A0000009B	150	1850		Chrome / Nikel
22A0000010B	150	2060		
22A0000011B	150	2270		
22A0000012B	150	2480		

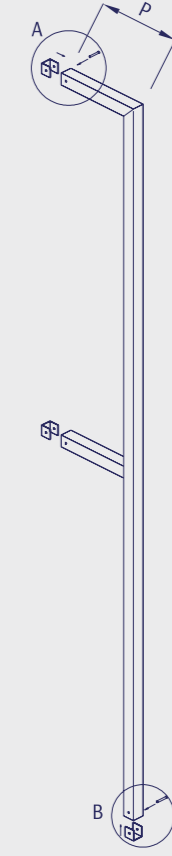
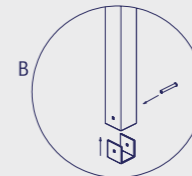
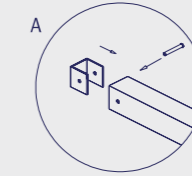

**TEXTILE &
SHOES**
TEKSTİL &
AYAKKABI

BOUTIQUE SYSTEM WOODEN SHELF BUTİK SİSTEM AHŞAP RAF

Code / Kod	P	H	L	Description / Açıklama
22A0000013U	300		540	Will be used to gether with
22A0000014U	300		840	"Boutique system upright".
22A0000015U	400		540	Butik sistem" duvara bağlantı
22A0000016U	400		840	dikme" ile kullanılır.
22A0000017U	500		540	
22A0000018U	500		840	

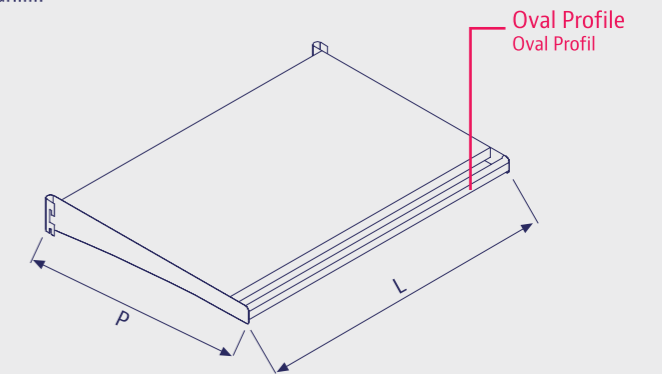



TEXTILE &
SHOES
TEKSTİL &
AYAKKABI

BOUTIQUE SYSTEM REAR BAR BUTİK SİSTEM ASKI (20X40)

Code / Kod	P	H	L	Description / Açıklama
22A0000019B	60		540	The accessories for standard rear bar can be to gether with boutique system rear bar. Standart askı tutucu ile kullanılan aksesuarlar, butik sistem askı tutucu ile de kullanılabilir.
22A0000020B	60		840	

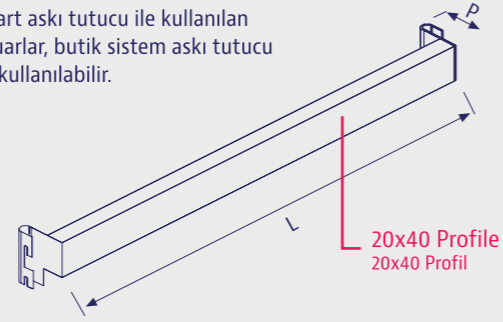

BOUTIQUE SYSTEM OVAL REAR BAR BUTİK SİSTEM ASKI (15X30)

Code / Kod	P	H	L	Description / Açıklama
22A0000021B	60		540	The accessories for standard rear bar can be to gether with boutique system rear bar. Standart askı tutucu ile kullanılan aksesuarlar, butik sistem oval askı tutucu ile de kullanılabilir.
22A0000022B	60		840	

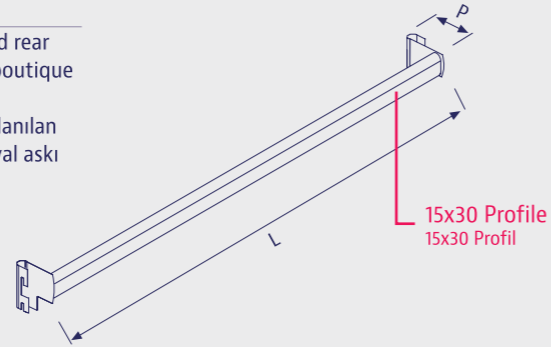

BOUTIQUE SYSTEM SLATTED BACK PANEL HOLDER BUTİK SİSTEM KANALLI ARKA PANO TUTUCU

Code / Kod	P	H	L	Description / Açıklama
22A0000023B	22		540	For 18 mm slatted back panel
22A0000024B	22		840	18 mm kanallı arka pano için

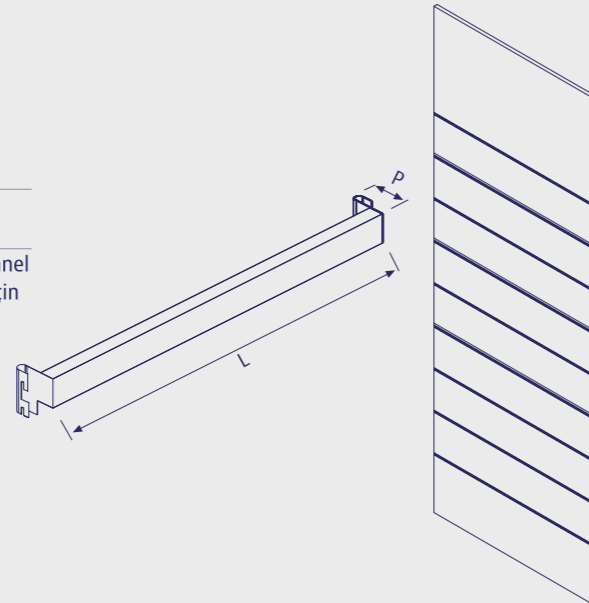

OHAIN PROFILE SYSTEM OHAIN PROFİL SİSTEM

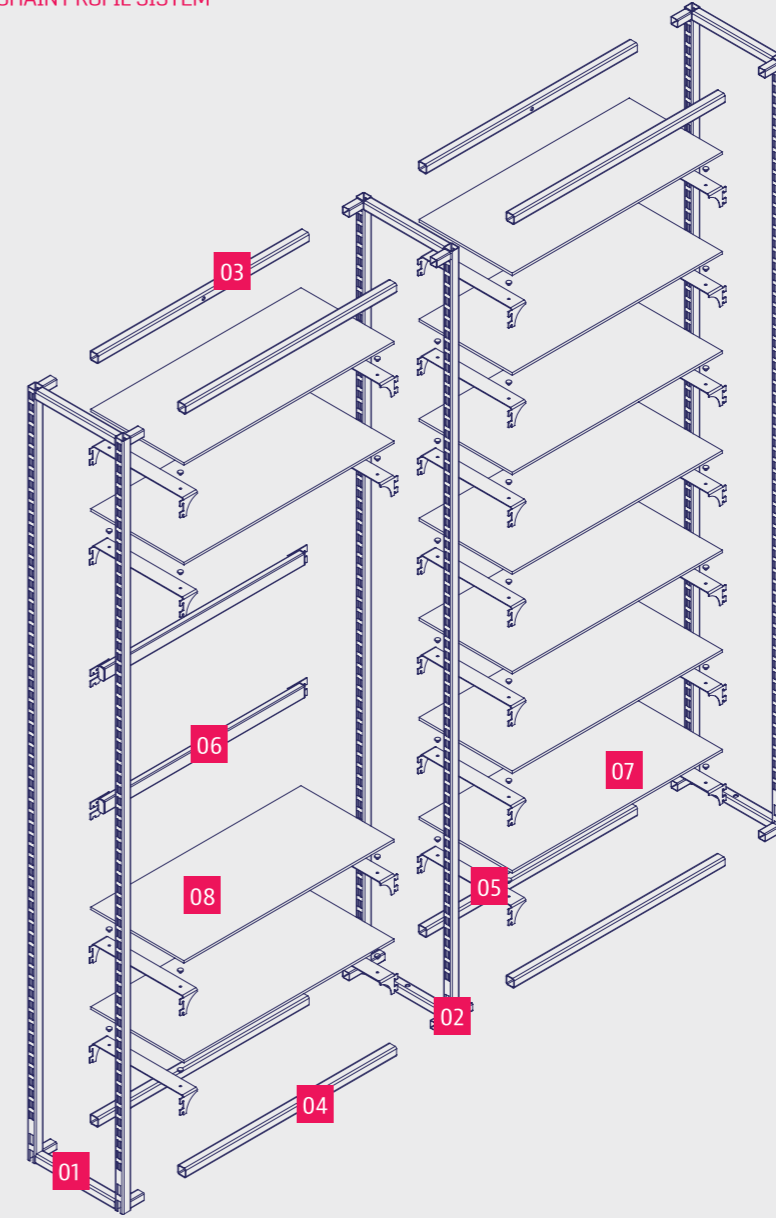

01
OHAIN Duvar Reyonu Ayak Bitiş
OHAIN Upright Sistem

02
OHAIN Duvar Reyonu Ayak Orta
OHAIN Upright Sistem Middle

03
OHAIN Atkı Profili Duvara Bağlantı Delikli
OHAIN Fixing Beam

04
OHAIN Atkı Profili
OHAIN Fixing Profile

05
OHAIN Ünite Konsolu
OHAIN Bracket

06
OHAIN Askı Tutucu
OHAIN Rear Bar

07
Cam Raf 6 mm
Glass Shelf 6 mm

08
Ahşap Raf 18 mm
Wooden Shelf 18 mm



TEXTILE &
SHOES
TEKSTİL &
AYAKKABI



TEXTILE &
SHOES
TEKSTİL &
AYAKKABI

OHAIN GONDOLA PROFILE SYSTEM OHAIN SİSTEM ORTA REYON

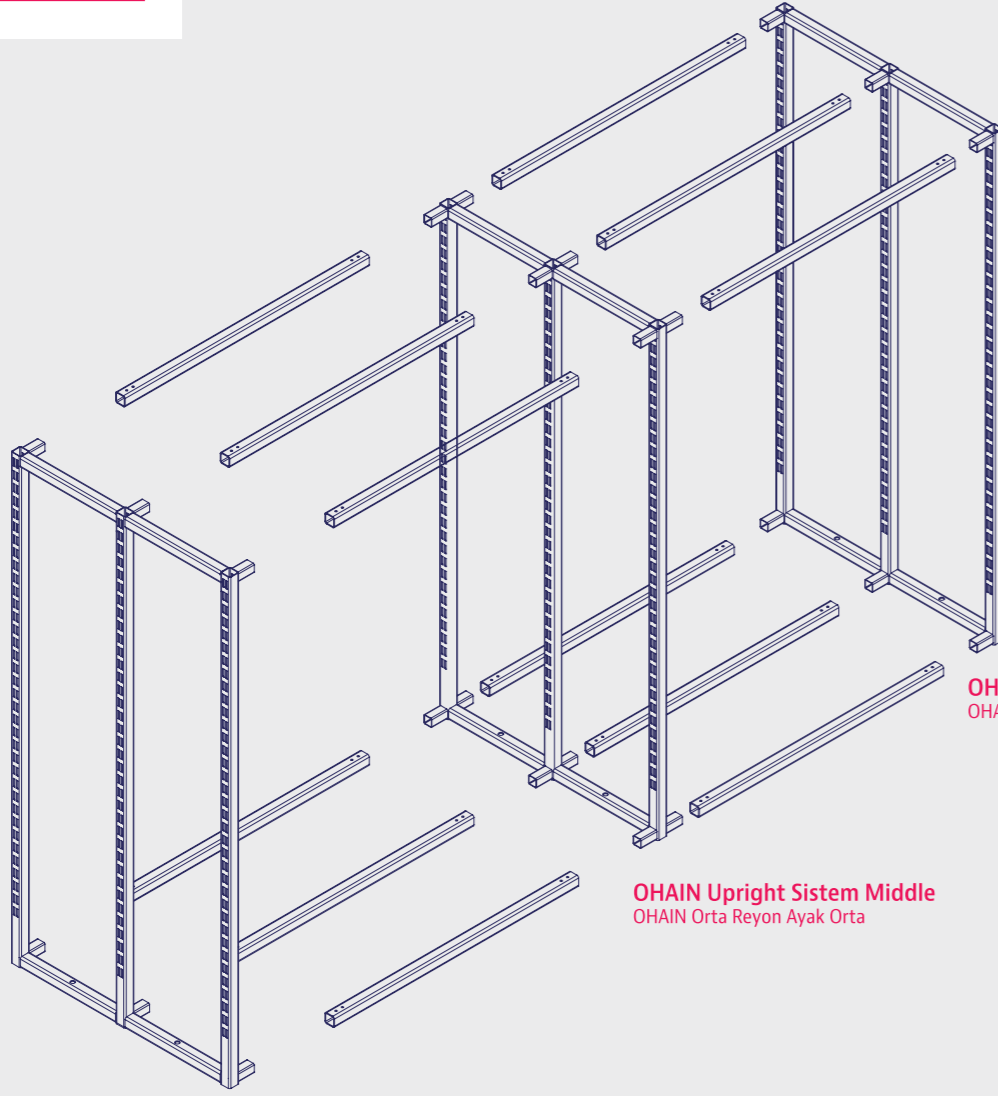

OHAIN Upright System
OHAIN Orta Reyon Ayak Bitiş

OHAIN Upright Sistem Middle
OHAIN Orta Reyon Ayak Orta

OHAIN Upright System
OHAIN Orta Reyon Ayak Bitiş

Code / Kod	P	H	L	Description / Açıklama
9A00000015.5B	690	1395		Ohain Orta Reyon Ayak Bitiş / OHAIN Upright System
9A00000015.6B	690	1395		Ohain Orta Reyon Ayak Orta / OHAIN Upright Sistem Middle



TEXTILE &
SHOES
TEKSTİL &
AYAKKABI

OHAIN WALL UNIT PROFILE SYSTEM OHAIN SİSTEM DUVAR REYONU

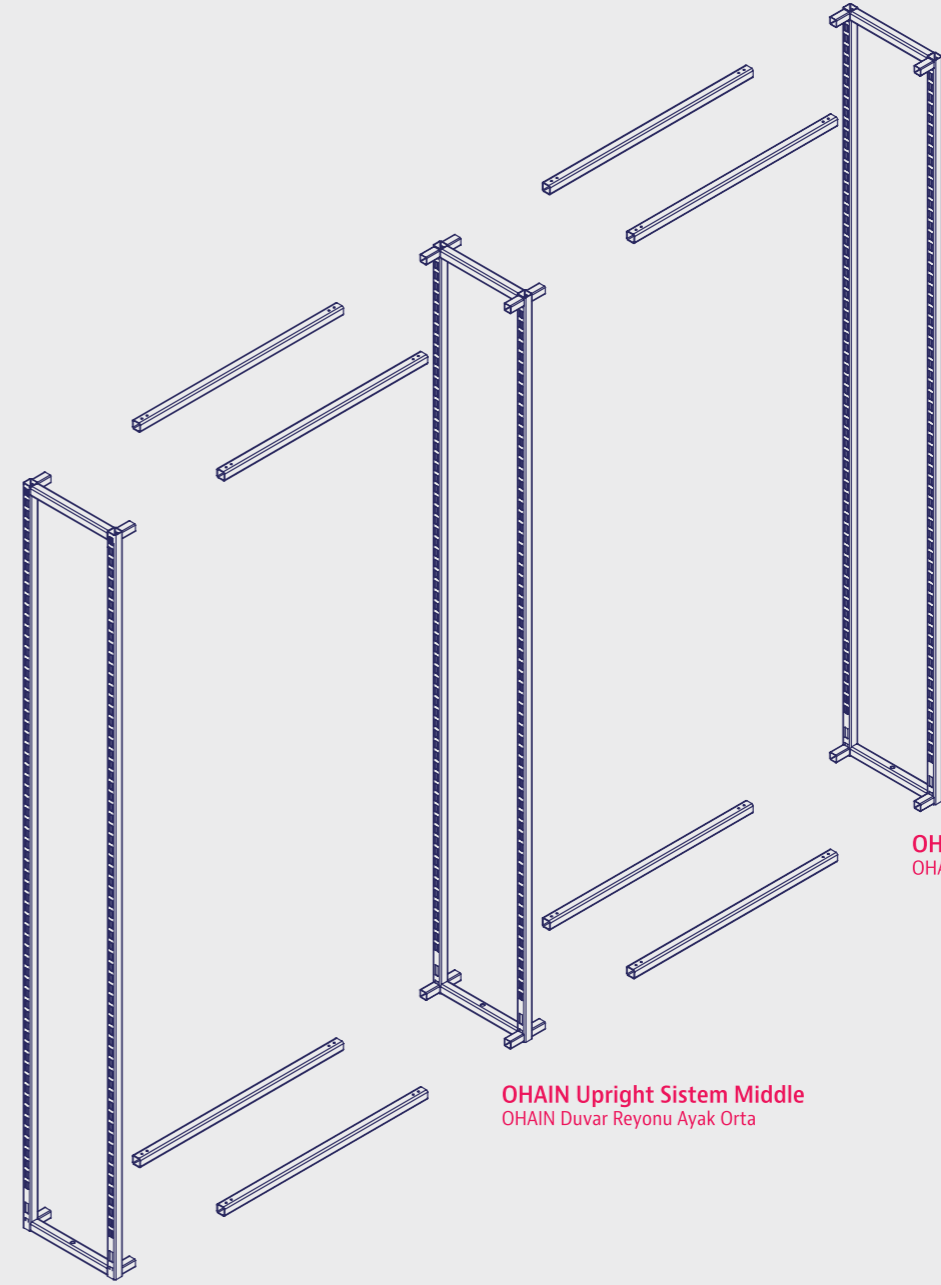

OHAIN Upright System
OHAIN Duvar Reyonu Ayak Bitiş

OHAIN Upright Sistem Middle
OHAIN Duvar Reyonu Ayak Orta

OHAIN Upright System
OHAIN Duvar Reyonu Ayak Bitiş

Code / Kod	P	H	L	Description / Açıklama
9A00000015.1B	350	2245		Profil Sistem Duvar Ayak Bitiş OHAIN Upright System
9A00000015.2B	350	2245		Profil Sistem Duvar Orta Ayak / OHAIN Upright Sistem Middle



TEXTILE &
SHOES
TEKSTİL &
AYAKKABI

OHAIN BRACKET OHAIN ÜNİTE KONSOL

Code / Kod	P	H	L	Description / Açıklama
9A00000015.7B	62		330	

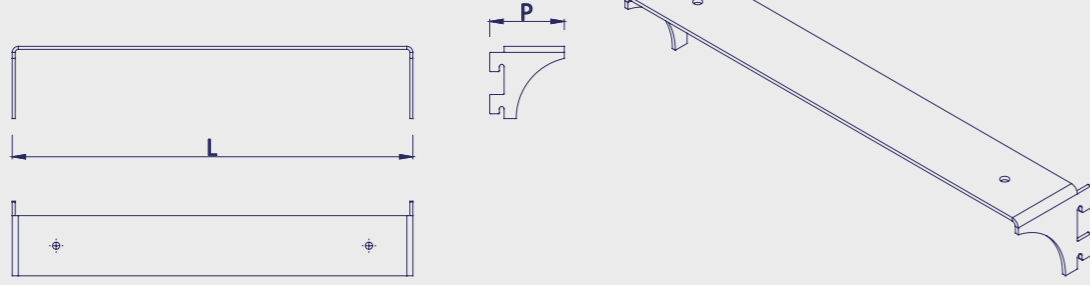

OHAIN GONDOLA HEAD BRACKET OHAIN GONDOLBAŞI KONSOL

Code / Kod	P	H	L	Description / Açıklama
6B00000039B	200			Sağ
6B00000040B	200			Sol

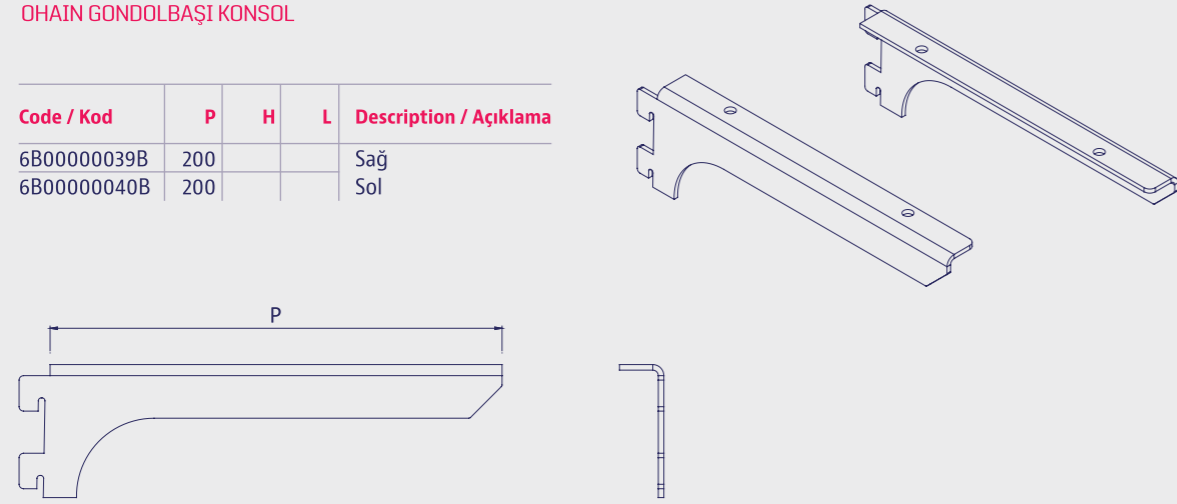

OHAIN HEADER OHAIN DUVAR ŞAPKA

Code / Kod	P	H	L	Description / Açıklama
7A00000118B		130	600	

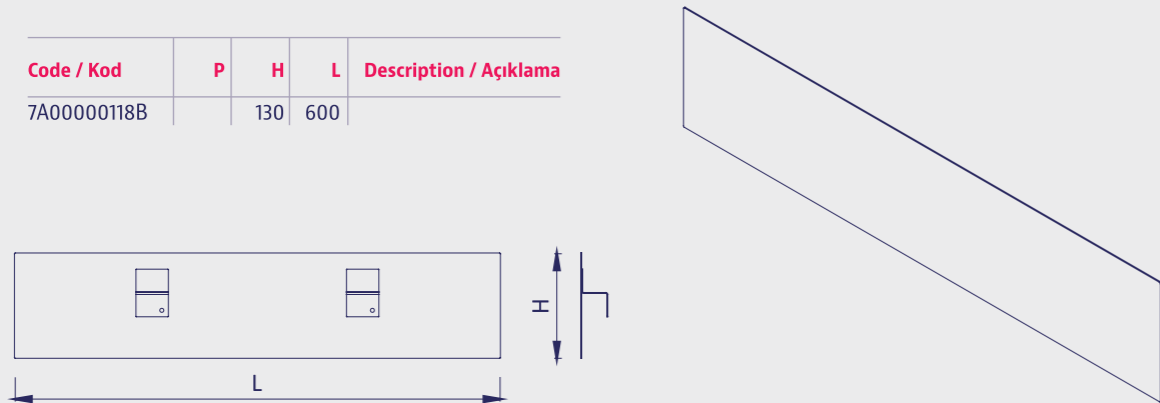

TEXTILE &
SHOES
TEKSTİL &
AYAKKABI

OHAIN FIXING BEAM OHAIN ATKI PROFİLİ DUV BAĞ DELİKLİ

Code / Kod	P	H	L	Description / Açıklama
9A00000015.8B			770	
9A00000015.10B			970	

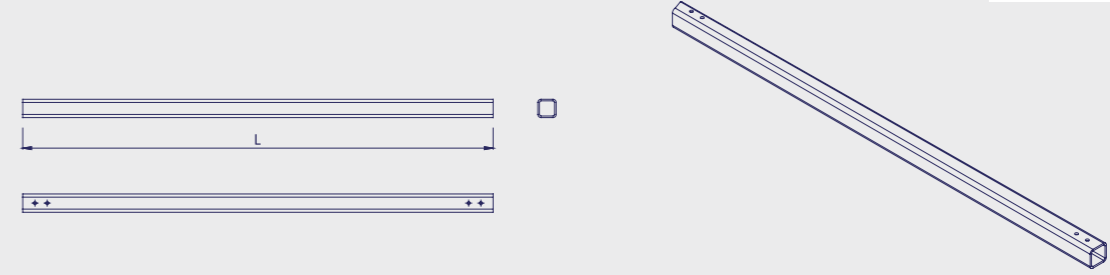

OHAIN FIXING PROFILE OHAIN ATKI PROFİLİ

Code / Kod	P	H	L	Description / Açıklama
9A00000015.9B			770	
9A00000015.11B			970	

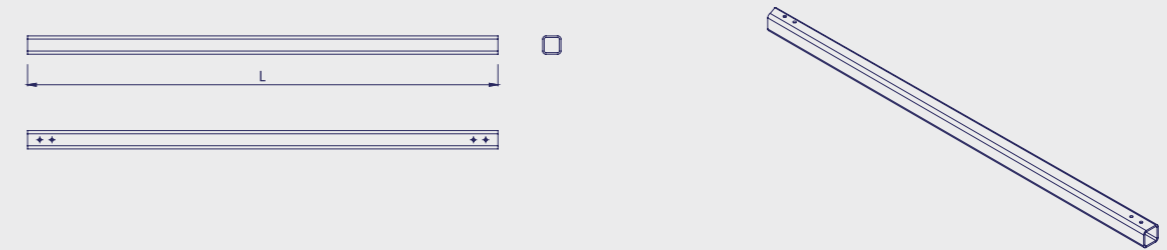

OHAIN REAR BAR OHAIN ASKU TUTUCU

Code / Kod	P	H	L	Description / Açıklama
9A00000015.12B		800		
9A00000015.13B		1000		

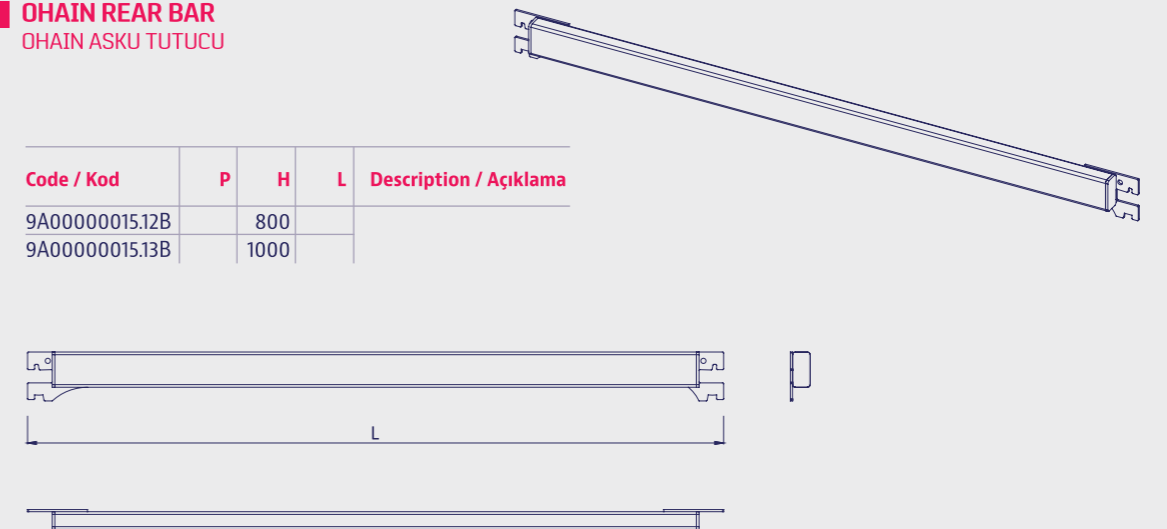



**TEXTILE &
SHOES**
TEKSTİL &
AYAKKABI

OHAIN GONDOLA HEADER
OHAIN ORTA REYON ŞAPKA

Code / Kod	P	H	L	Description / Açıklama
10B0000117B		130	600	

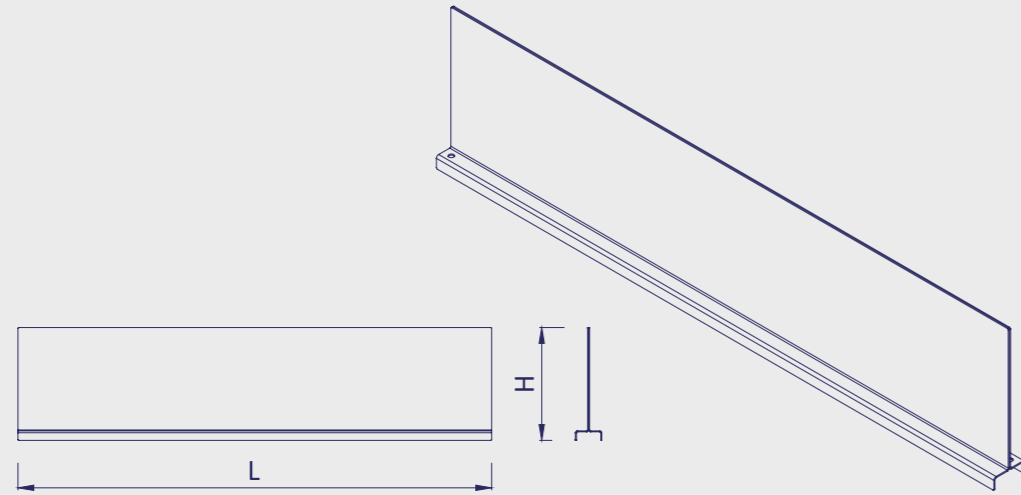

SAMPLE UNIT FOR OHAIN SYSTEM
OHAIN SİSTEM ÖRNEK ÜNİTELER

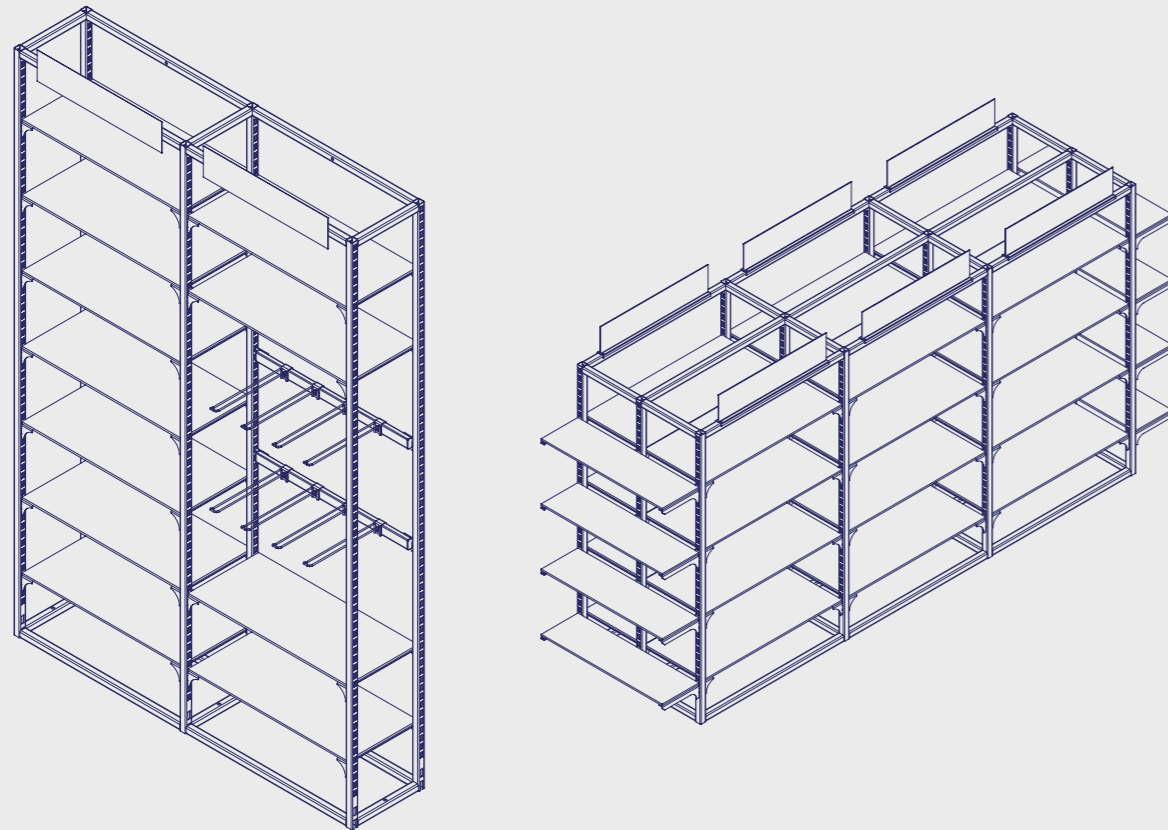

SALMON WALL UNIT
SALMON DUVAR REYONU

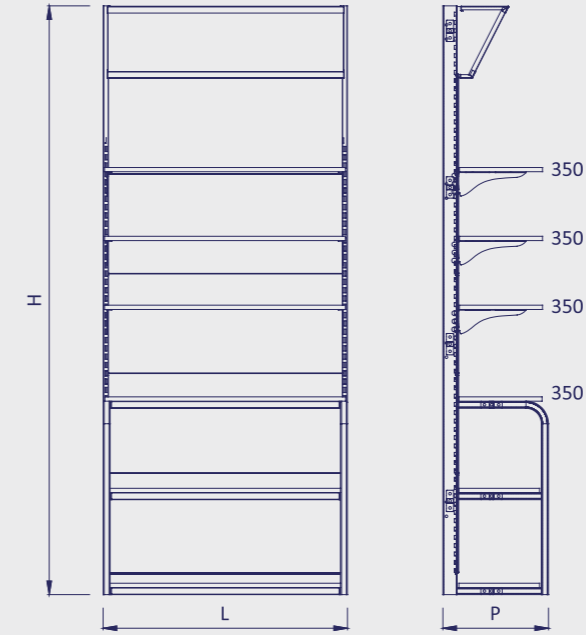

**TEXTILE &
SHOES**
TEKSTİL &
AYAKKABI

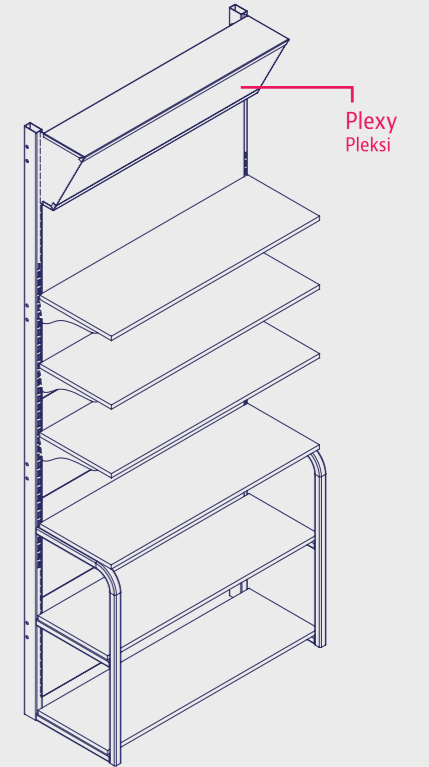

Code / Kod	P	H	L	Description / Açıklama
22A0000028U	445	2480	1000	



**TEXTILE &
SHOES**
TEKSTİL &
AYAKKABI

GAYA WARDROBE FOR CUSTOMER 12 POSSESSION
GAYA 12 GÖZLÜ AHŞAP EMANET DOLABI

Code / Kod	P	H	L	Description / Açıklama
8D00000006M	400	1500	1050	Electronic / Elektronik
8D00000007M	400	1500	1050	Anahtarlı

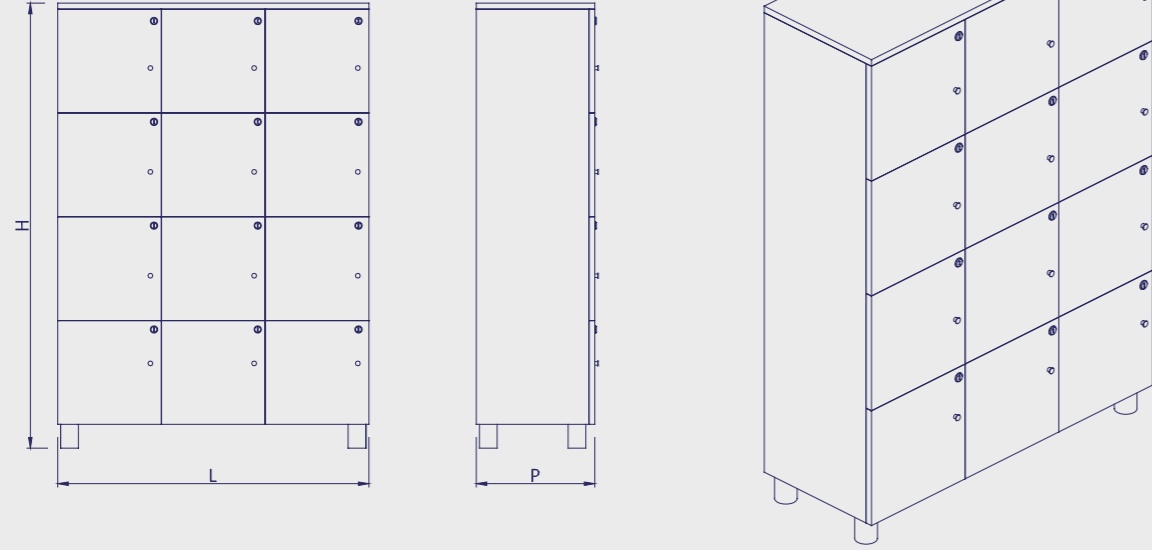

SEPIA WOODEN CUPBOARD
SEPİA AHŞAP DOLAP

Code / Kod	P	H	L	Description / Açıklama
22A0000029M	500	2000	500	Electronic / Elektronik

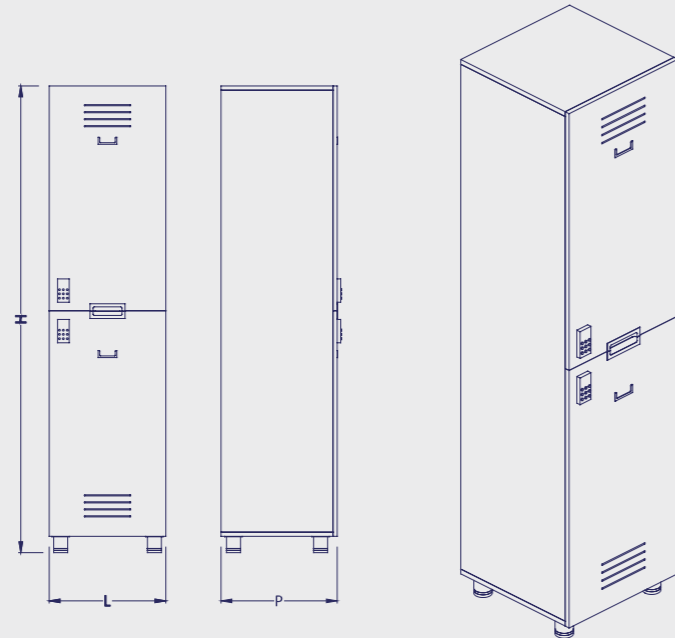

**TEXTILE &
SHOES**
TEKSTİL &
AYAKKABI

FRAME WALL UNIT
FRAME DUVAR REYONU

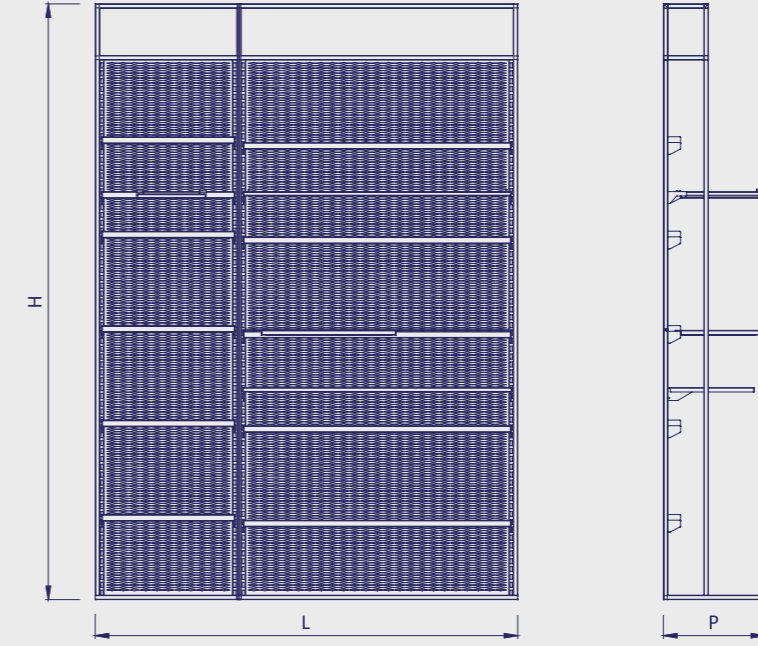

Code / Kod	P	H	L	Description / Açıklama
22A0000030U	450	2650	1880	Aksesuar detayları ile ilgili bilgi isteyiniz.

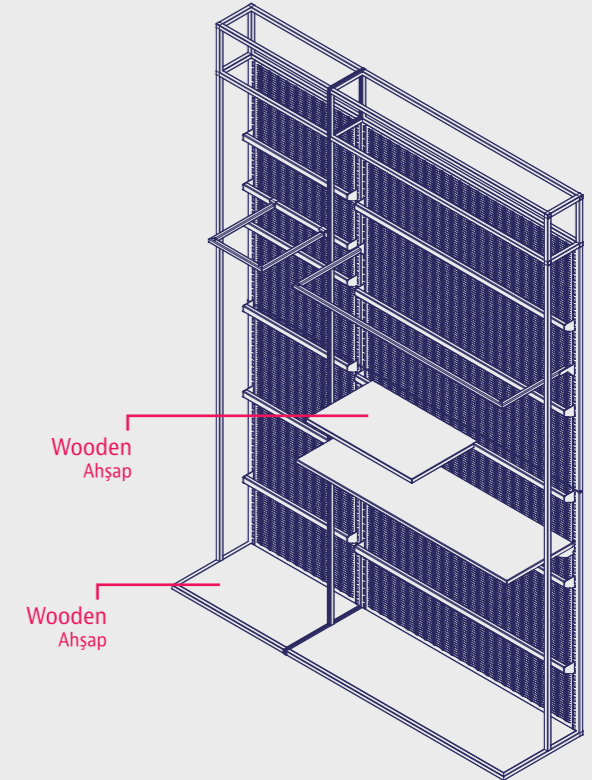



TEXTILE &
SHOES
TEKSTİL &
AYAKKABI

CAPRİ PROFILE UNIT
CAPRİ ŞAPKA REYONU

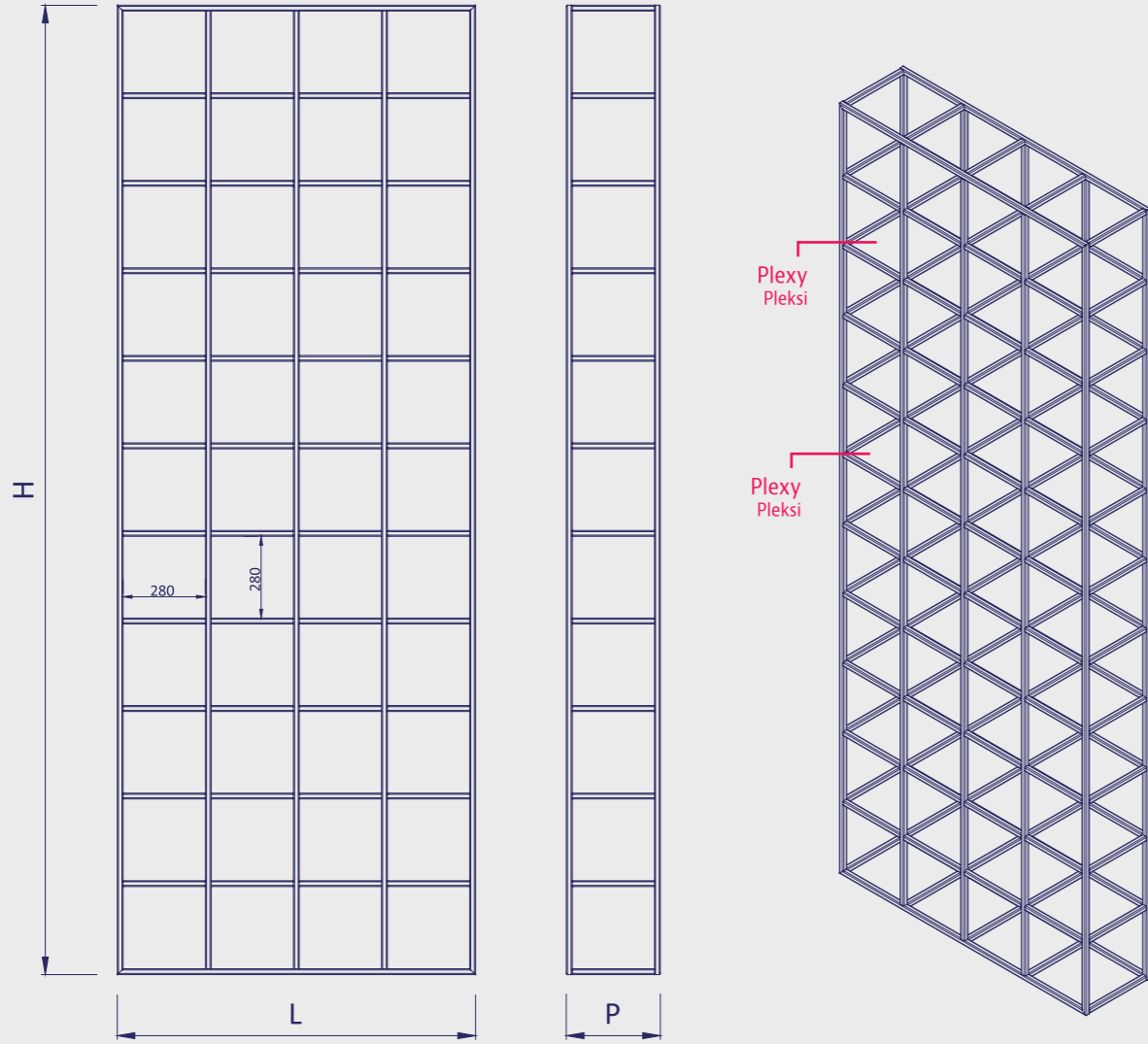

Code / Kod	P	H	L	Description / Açıklama
22A0000031U	320	3300	1220	Pleksi olan zemin ahşap olarak uygulanabilmektedir.



TEXTILE &
SHOES
TEKSTİL &
AYAKKABI

RESEDA STAND
RESEDA STAND

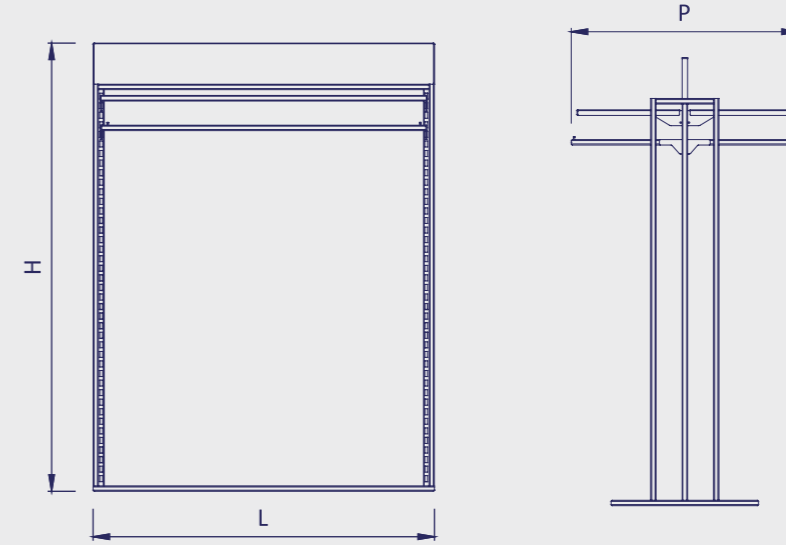

Code / Kod	P	H	L	Description / Açıklama
22A0000032U	830	1640	1250	

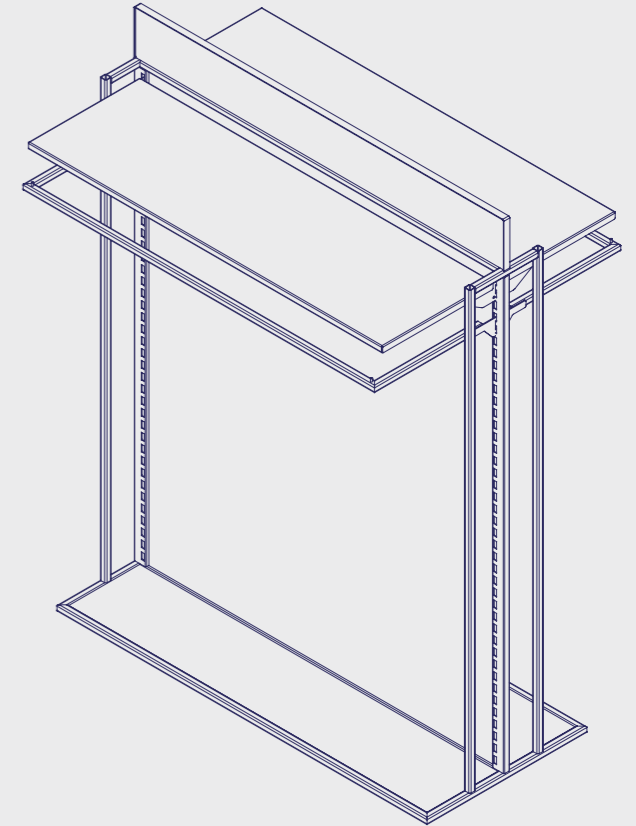



TEXTILE &
SHOES
TEKSTİL &
AYAKKABI

MOSS STAND
MOSS STAND

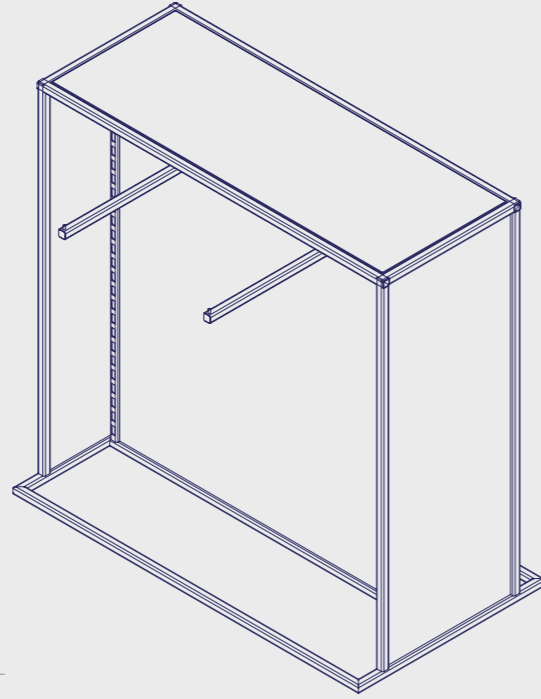
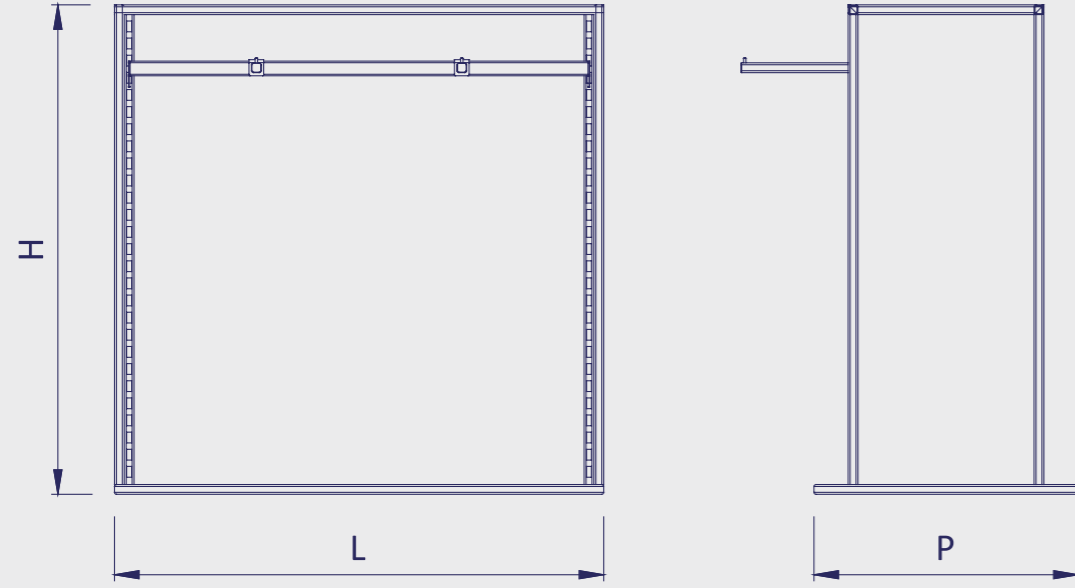

Code / Kod	P	H	L	Description / Açıklama
22A0000033U	540	1000	1000	



TEXTILE &
SHOES
TEKSTİL &
AYAKKABI

PODOS WOODEN GONDOLA STAND
PODOS AHŞAP ORTA STAND

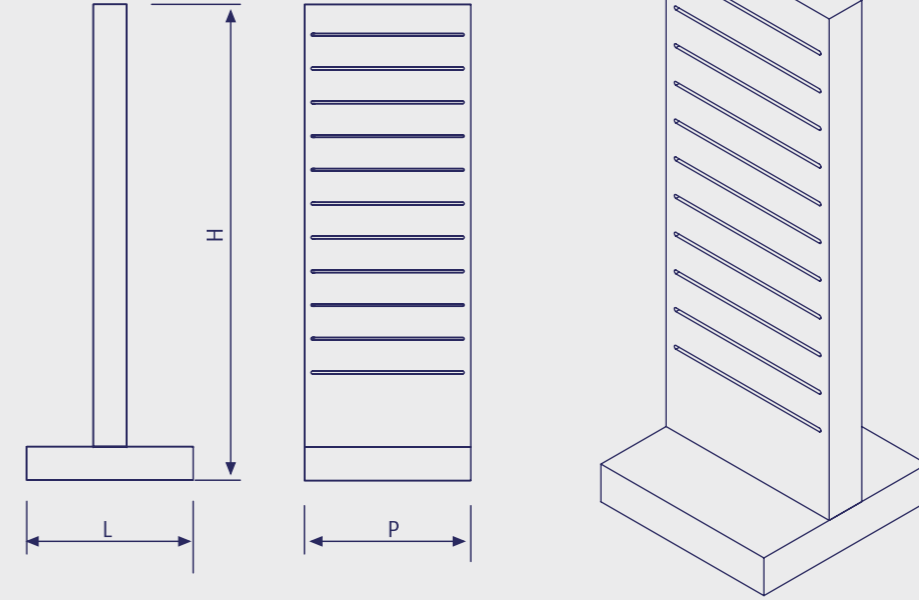

Code / Kod	P	H	L	Description / Açıklama
8D00000010U	500	1430	500	Accessories will be added seperately Aksesuarlar ayrıca eklenecektir.

NIKS GONDOLA UNIT WITH WHEELS
NIKS TEKERLEKLİ ORTA REYON

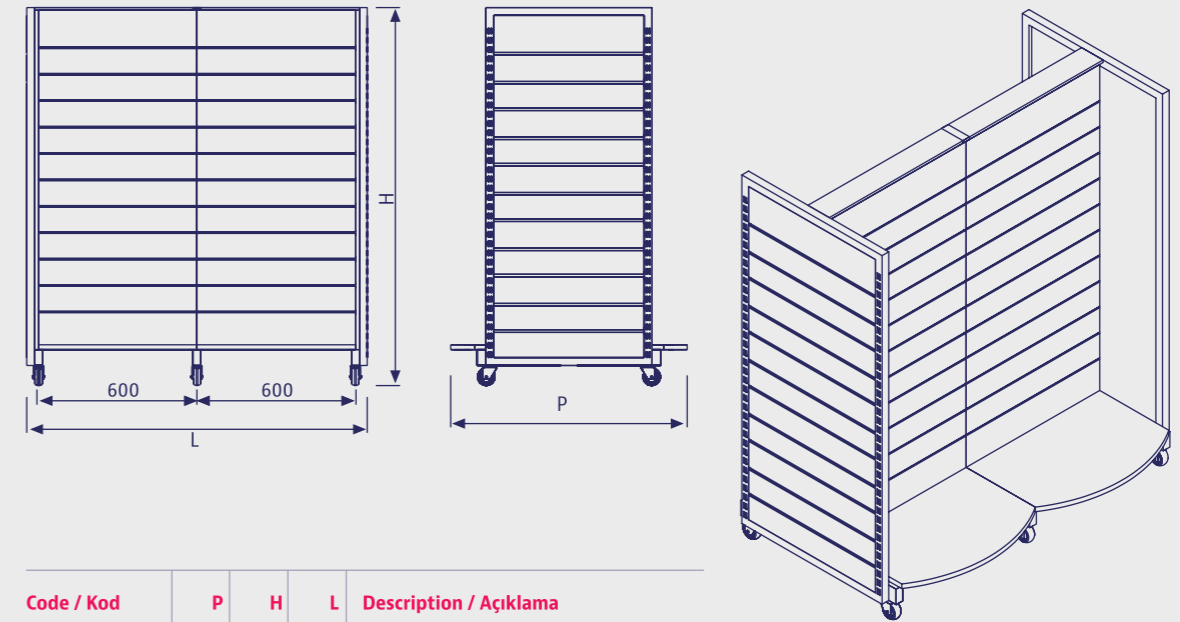

Code / Kod	P	H	L	Description / Açıklama
8D00000004U	900	1430	1300	Accessories will be added seperately Aksesuarlar ayrıca eklenecektir.



**TEXTILE &
SHOES**
TEKSTİL &
AYAKKABI

IMERA GONDOLA UNIT WITH WHEELS
IMERA TEKERLEKLİ ORTA REYON

Code / Kod	P	H	L	Description / Açıklama
8D90050005U	400	1550	1200	

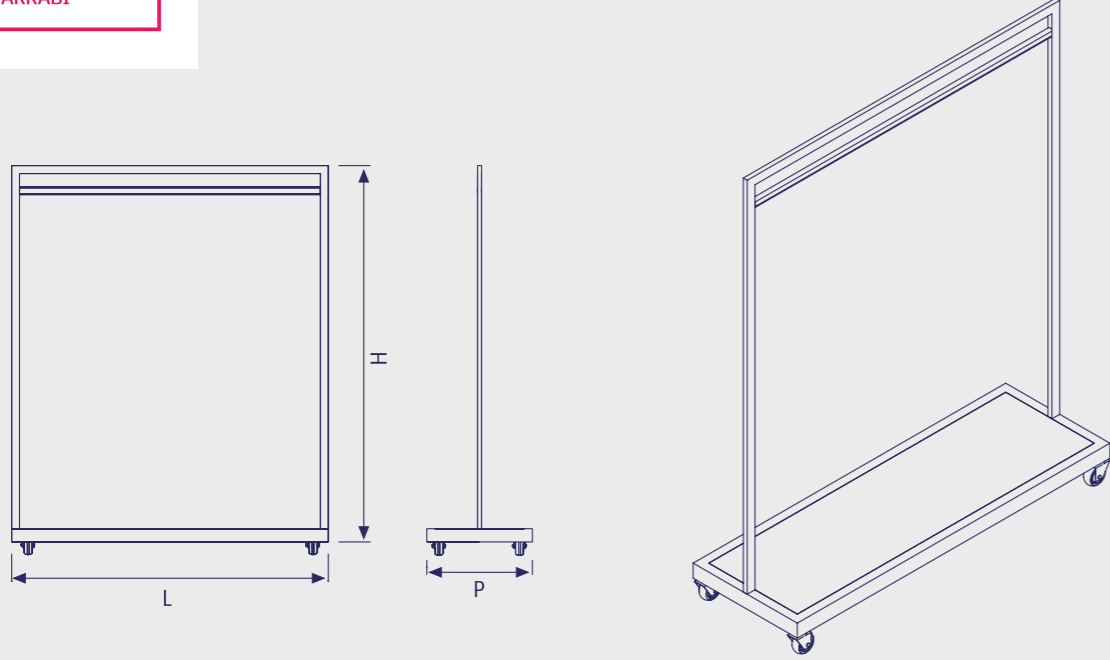

ARGOS ACROBAT
ARGOS AKROBAT

Code / Kod	P	H	L	Description / Açıklama
8D00000040U	600	1370	1200	Görseldeki aksesuarlar için bilgi isteyiniz.

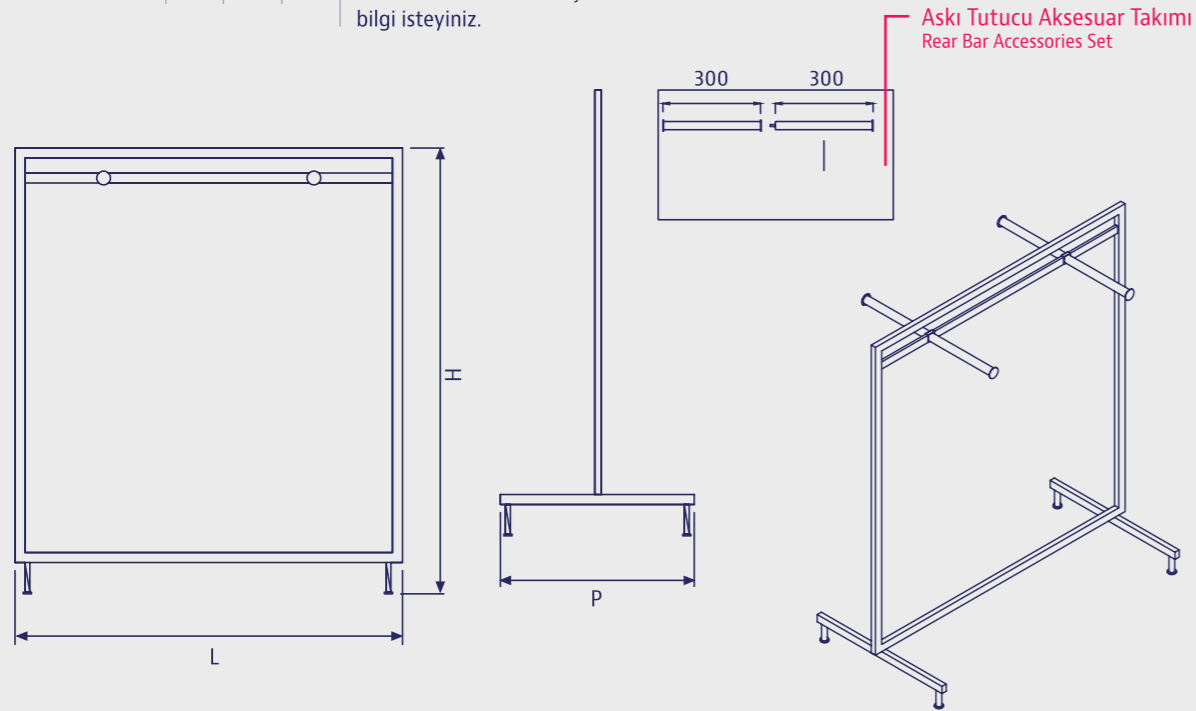

URANUS ACROBAT
URANUS 4 KOLLU AKROBAT

Code / Kod	P	H	H1	L	Description / Açıklama
8D00000008U	500	940	1200	1000	

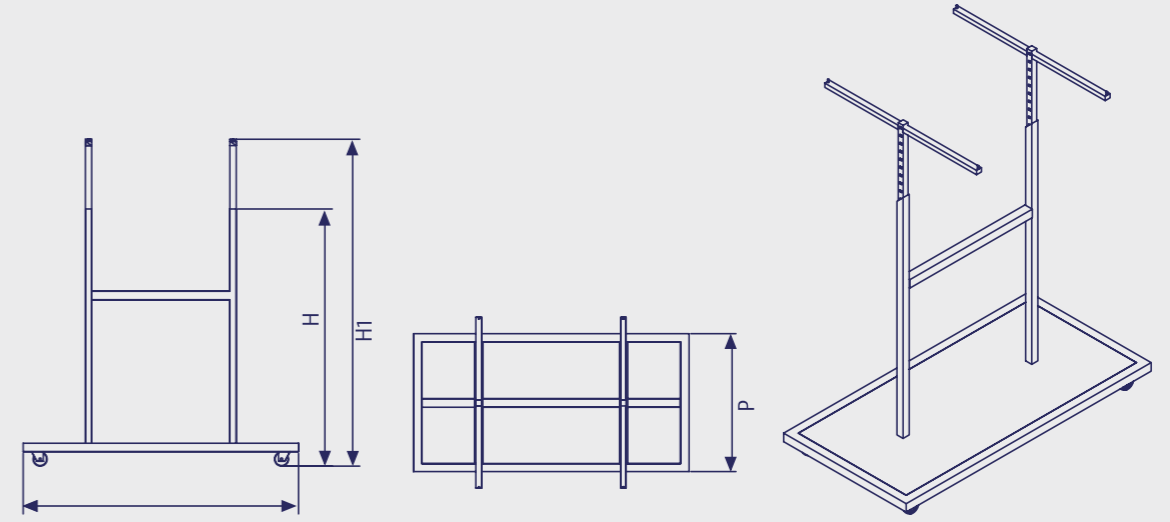

UREA ACROBAT
UREA KOLLU AKROBAT

Code / Kod	P	H	L	Description / Açıklama
8D00000009U	500	935	1000	

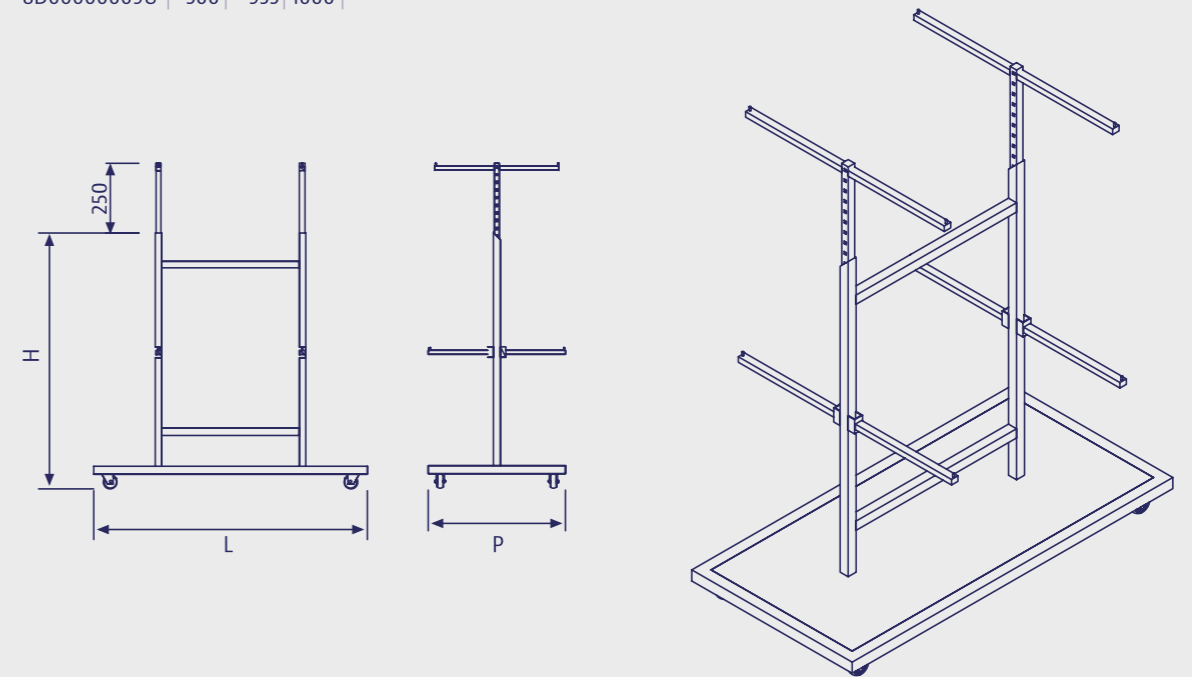

**TEXTILE &
SHOES**
TEKSTİL &
AYAKKABI



**TEXTILE &
SHOES**
TEKSTİL &
AYAKKABI

VIDAR GONDOLA STAND
VİDAR ORTA STAND

Code / Kod	P	H	L	Description / Açıklama
8D00000046U	650	1400	650	

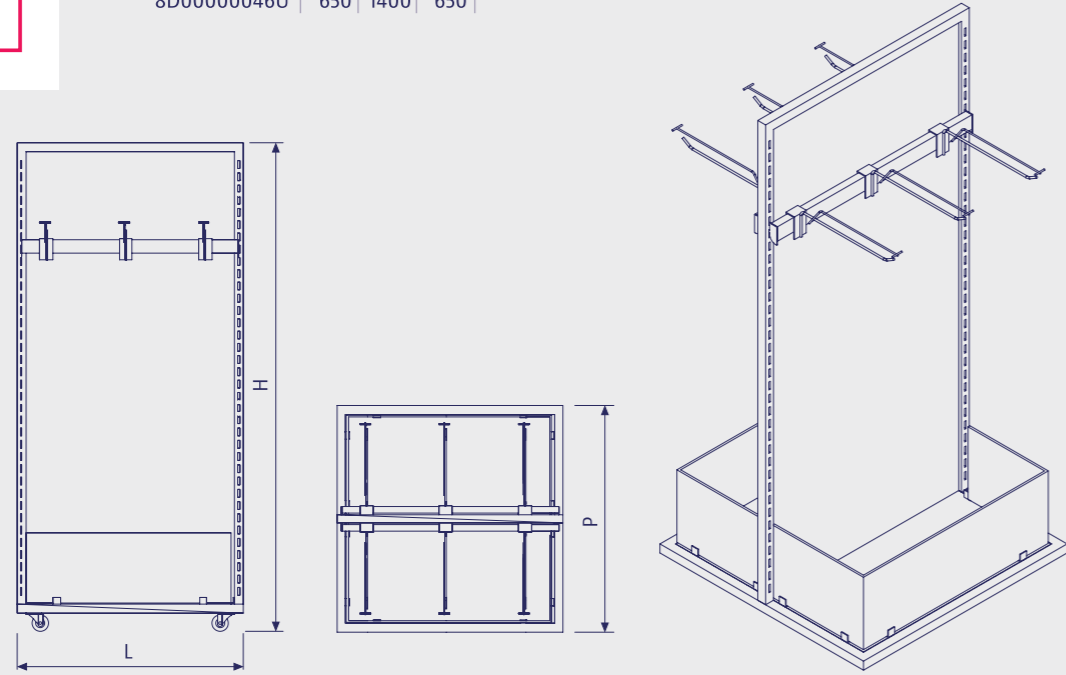

**TEXTILE &
SHOES**
TEKSTİL &
AYAKKABI

TITHIS WALL UNIT FOR SHOES
TİTHİS AHŞAP AYAKKABI STANDI

Code / Kod	P	H	L	Description / Açıklama
8D00000015U	400	2500	1440	

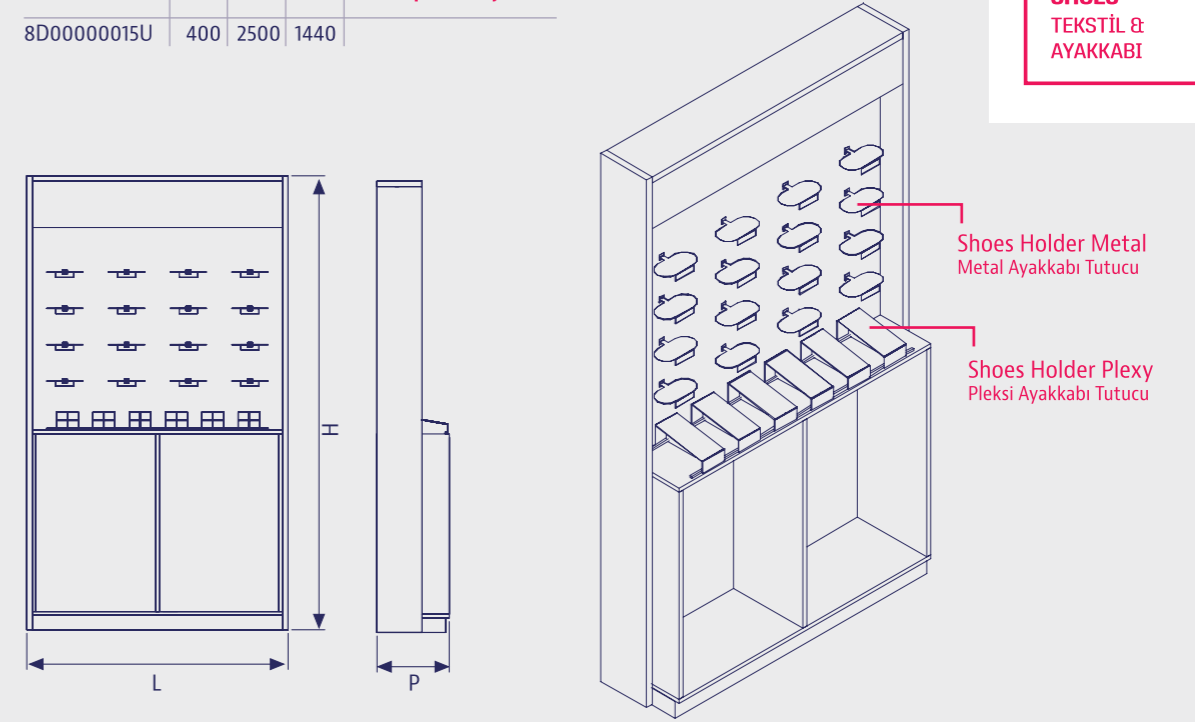

TARTAROS MULTI LAYERED TABLE
TARTAROS KATLI ORTA SEHPA

Code / Kod	P	H	L	Description / Açıklama
8D00000011U	1700	1100	1220	

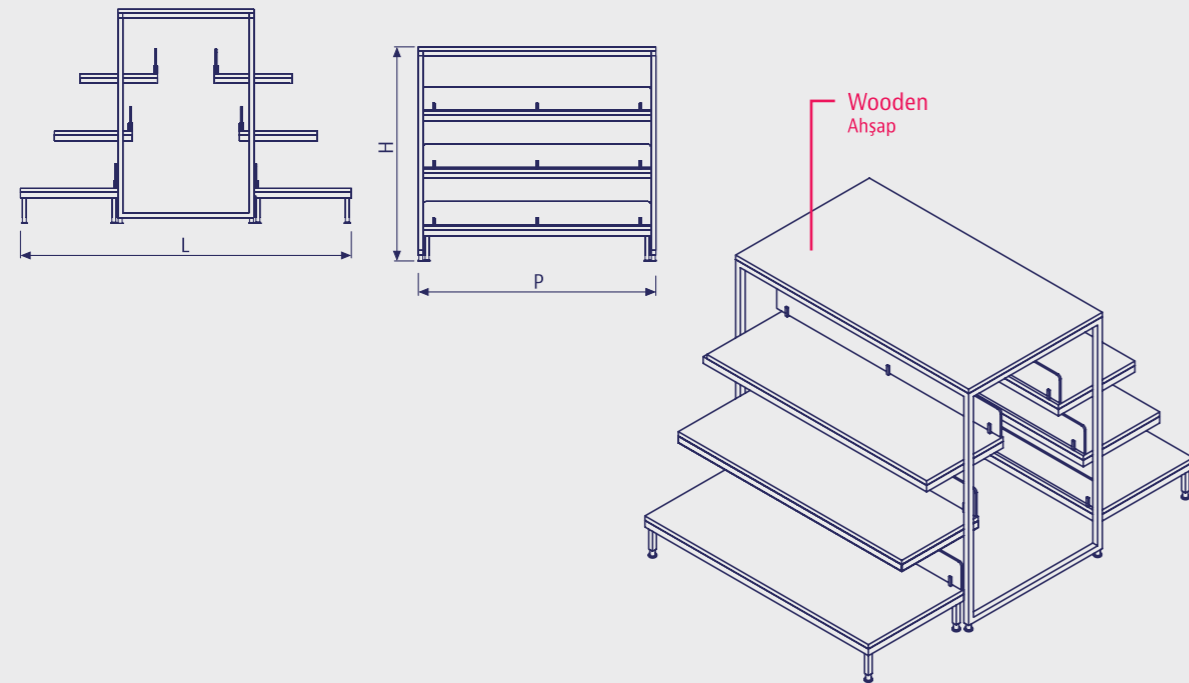

FIVI WALL UNIT FOR SHOES WITH SLIDING STAND
FİVİ SÜRGÜLÜ KAPAKLI AYAKKABI STANDI

Code / Kod	P	H	L	Description / Açıklama
8D00000016U	500	2270	3600	Each module 900 mm Her modül 900 mm

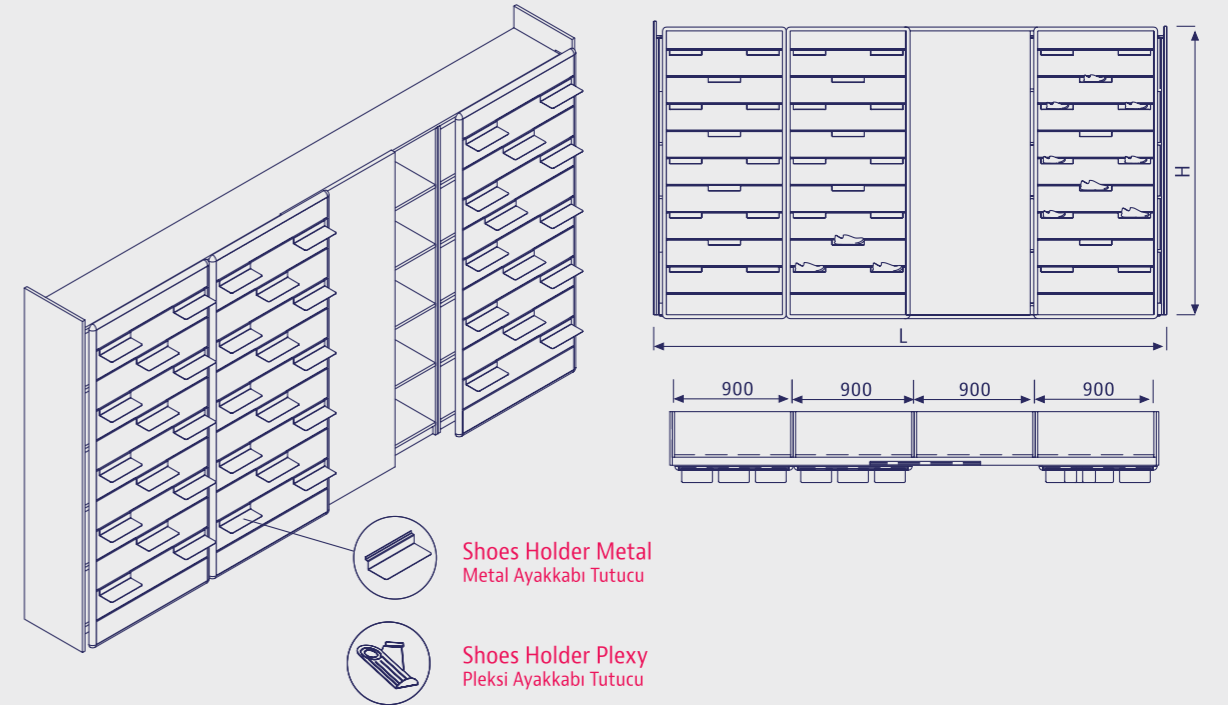



TEXTILE &
SHOES
TEKSTİL &
AYAKKABI

THEMIS SHOES STAND
THEMİS AYAKKABI STANDI

Code / Kod	P	H	L	Description / Açıklama
8D00000017U	830	1400	900	Gondola Ahşap Çerçeve Takım
8D00000039U	100	1400	830	Each module L: 90 cm Her modül 90 cm

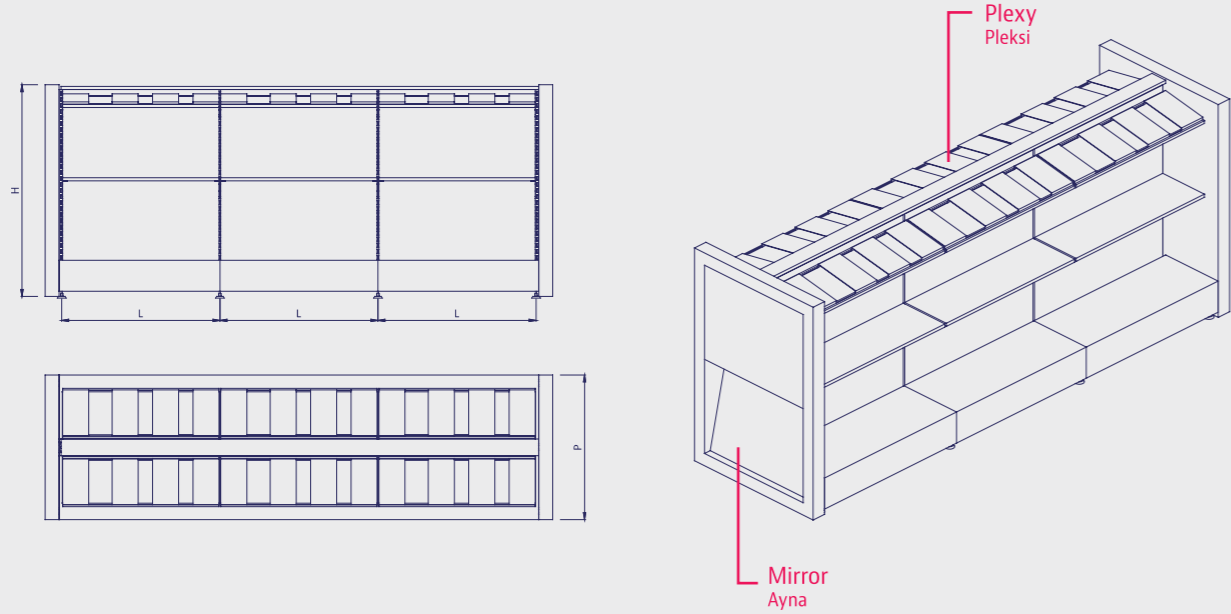

KRONOS ACROBAT
KRONOS AKROBAT

Code / Kod	P	H	L	Description / Açıklama
8D00000013N	950	1400	640	

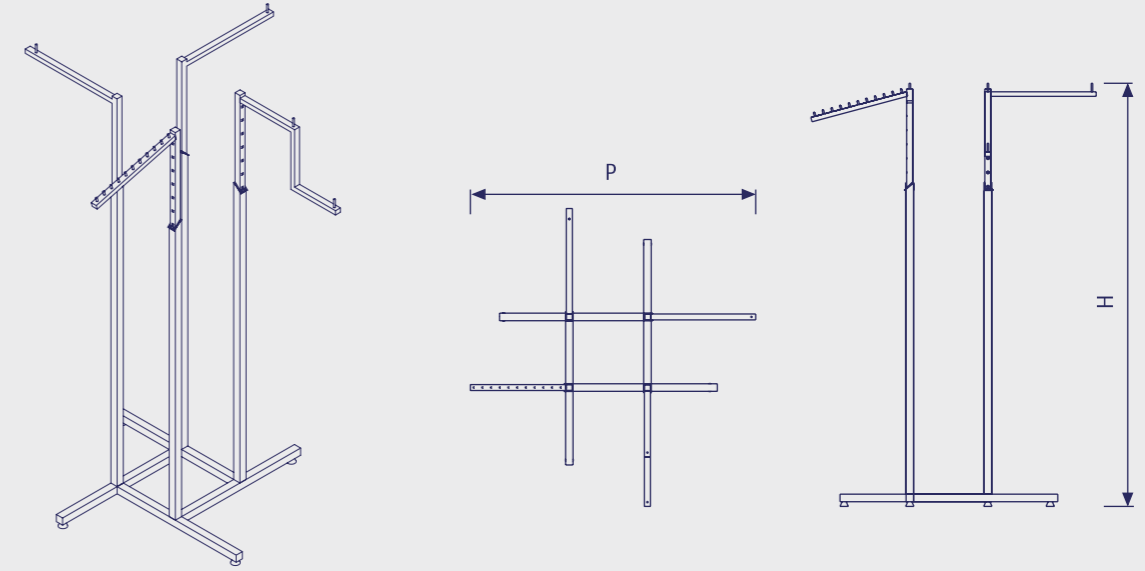

TEXTILE &
SHOES
TEKSTİL &
AYAKKABI

VESTA SHOES STAND
VESTA AYAKKABI STANDI

Code / Kod	P	H	L	Description / Açıklama
8D00000047U	750	1100	1660	

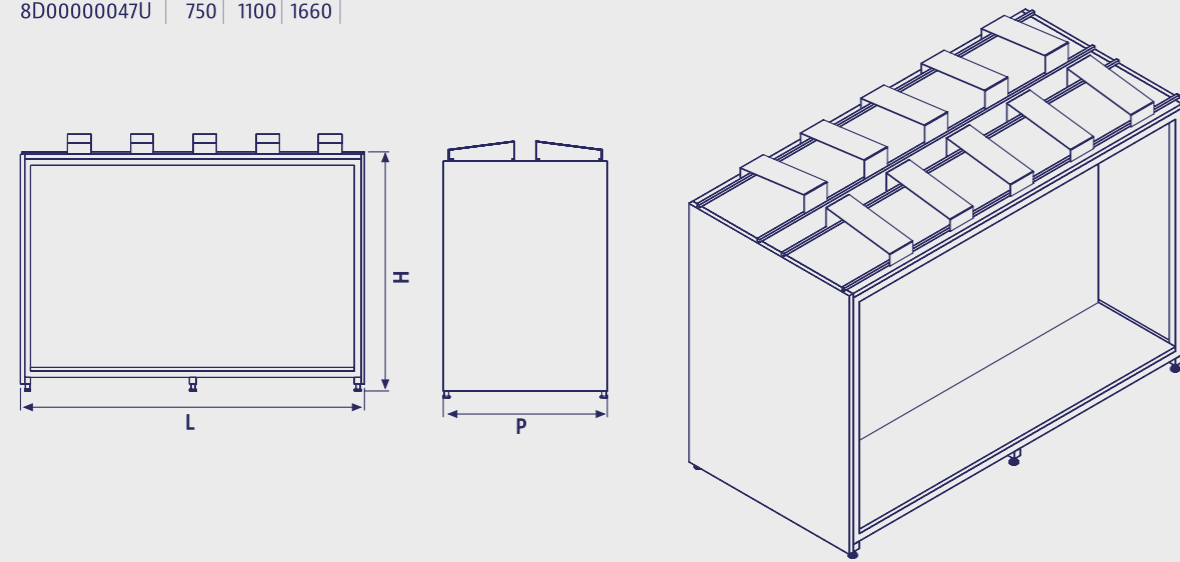

KRIYOS ACROBAT
KRIYOS AKROBAT

Code / Kod	P	H	L	Description / Açıklama
8D00000014N	480	1075	850	

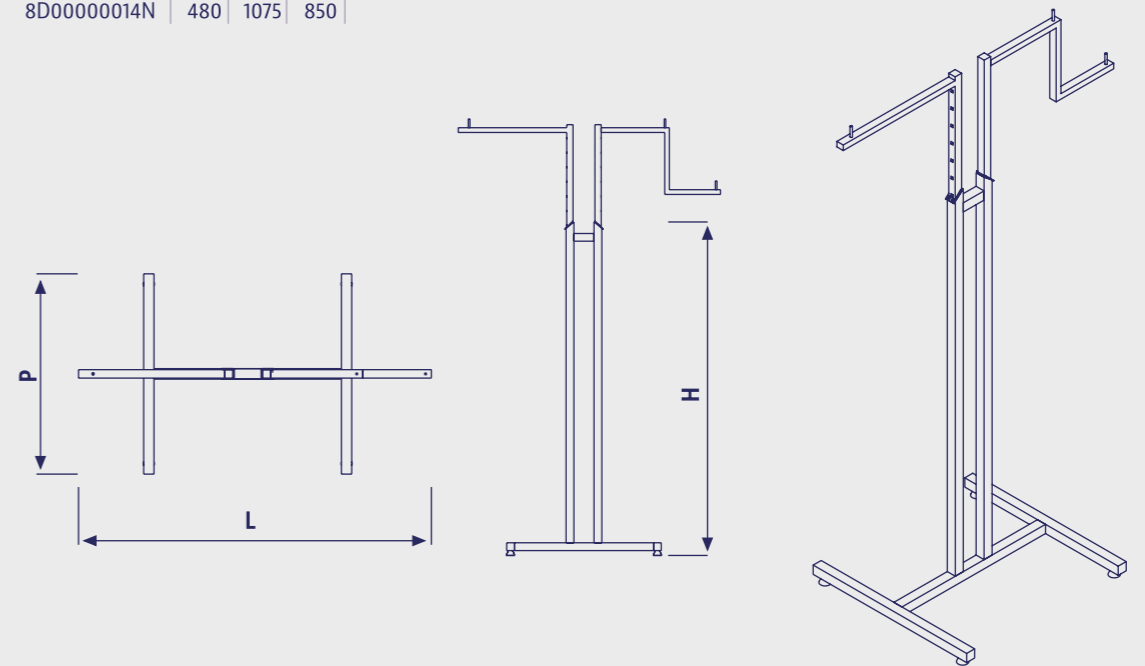



TEXTILE &
SHOES
TEKSTİL &
AYAKKABI

OKYANUS MULTI LAYERED TABLE
OKYANUS KATLI ORTA SEHPA

Code / Kod	P	H	L	Description / Açıklama
8D00000012U	500	1500	1500	With wooden / Ahşap Glass shelf / Cam Rafli Metal legs can be painted / Metal ayaklar boyalı Stainless steel / Paslanmaz olabilir

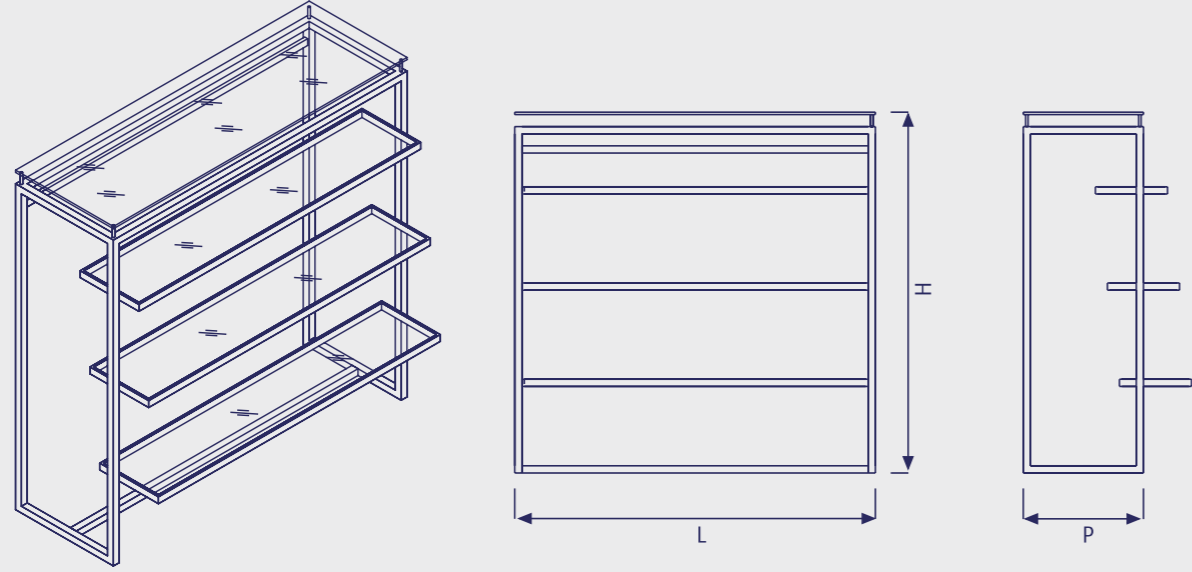

ASTERIA SHOE STAND
ASTERİA AYAKKABI STANDI

Code / Kod	P	H	L	Description / Açıklama
8D00000018M	1200	1370	1200	

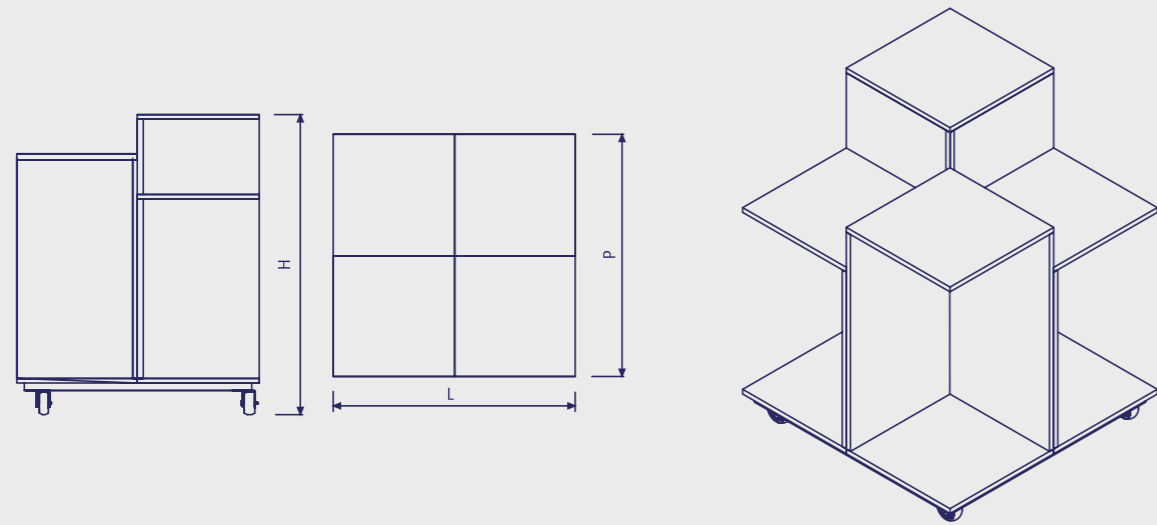

TEXTILE &
SHOES
TEKSTİL &
AYAKKABI

EVENOS ACROBAT
EVENOS AKROBAT

Code / Kod	P	H	L	Description / Açıklama
8D00000034U	1200	1640		

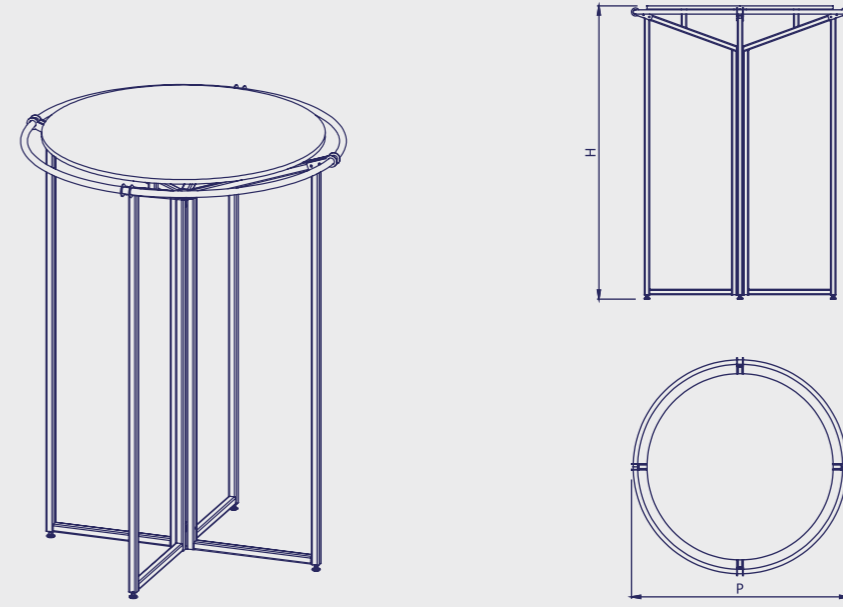

KELMİS ACROBAT
KELMİS AKROBAT

Code / Kod	P	H	L	Description / Açıklama
8D00000035U	550	1295	1200	

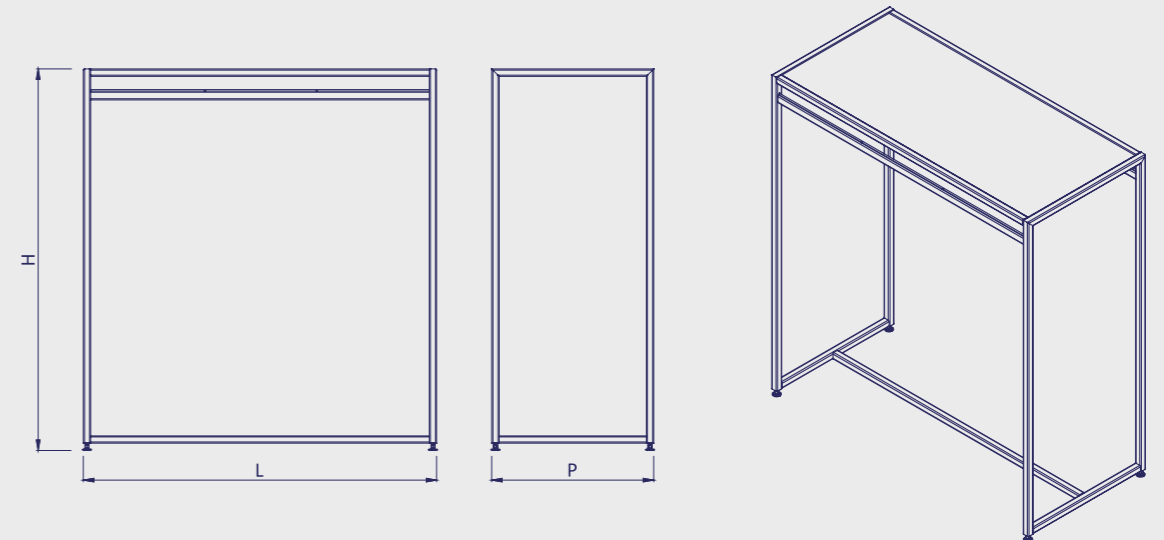



TEXTILE &
SHOES
TEKSTİL &
AYAKKABI

ABARIS ACROBAT
ABARİS AKROBAT

Code / Kod	P	H	L	Description / Açıklama
8D00000036U	550	1650	1200	

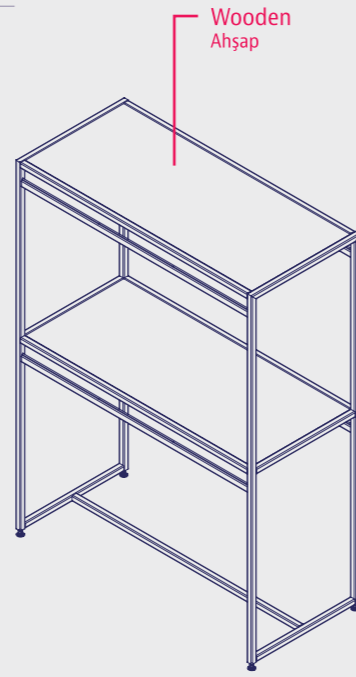
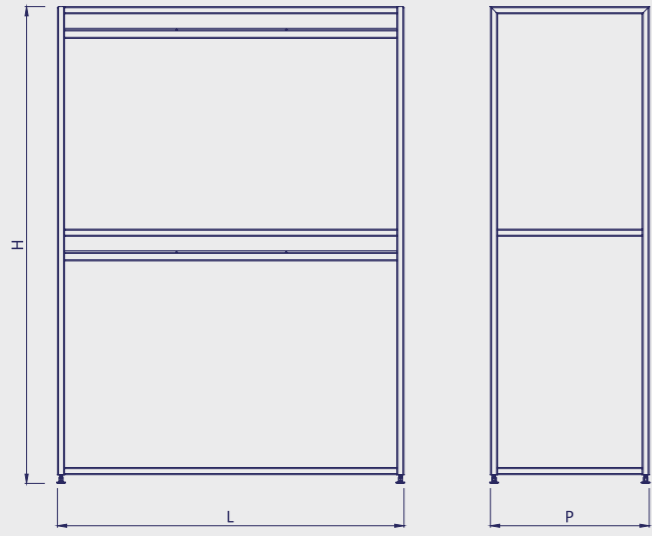

BENDİS ACROBAT
BENDİS AKROBAT

Code / Kod	P	H	L	Description / Açıklama
8D00000037U	1200	1650		

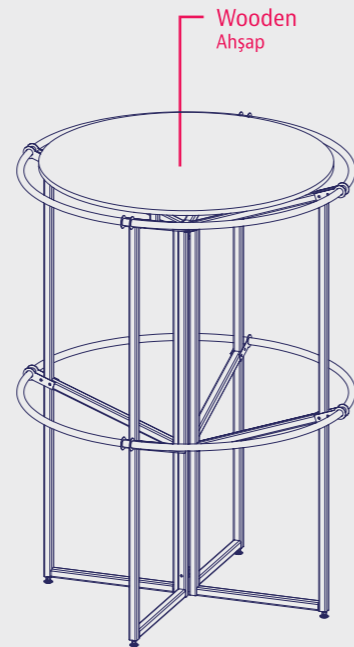
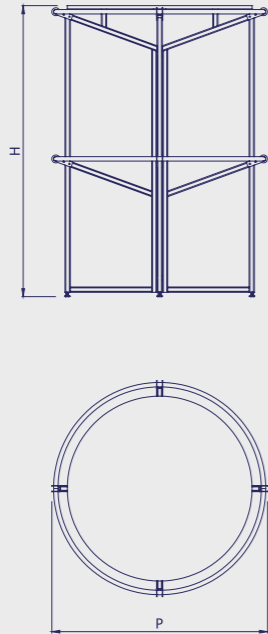

LİTO ACROBAT
LİTO AKROBAT

Code / Kod	P	H	L	Description / Açıklama
8D00000048U	900	1300		

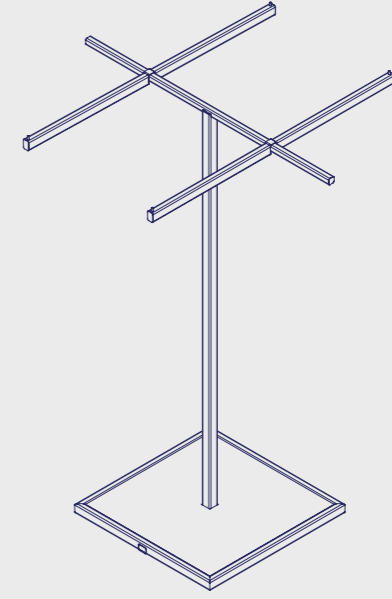
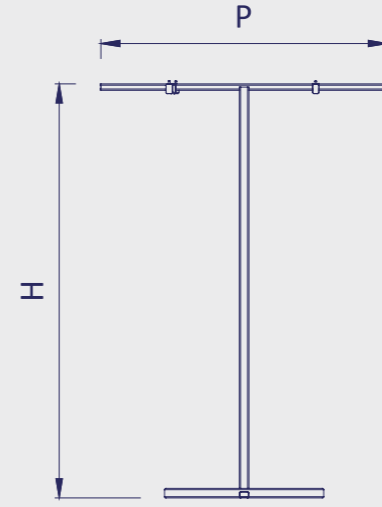

ODIN ACROBAT
ODİN AKROBAT

Code / Kod	P	H	L	Description / Açıklama
8D00000049U	500	1300	1200	

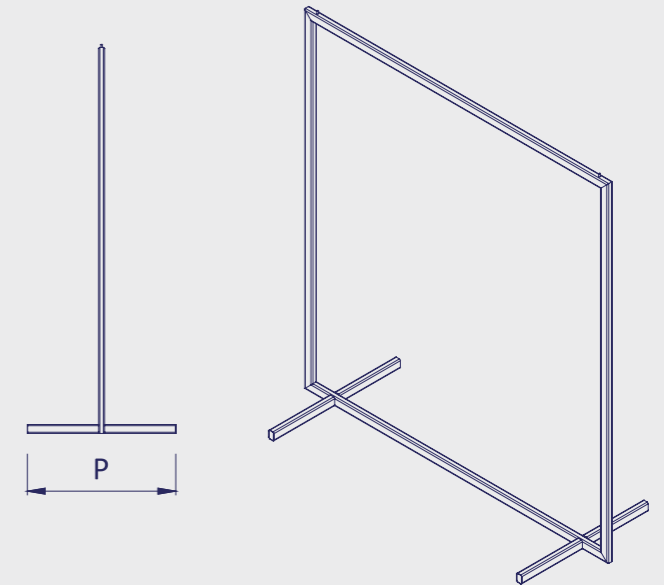
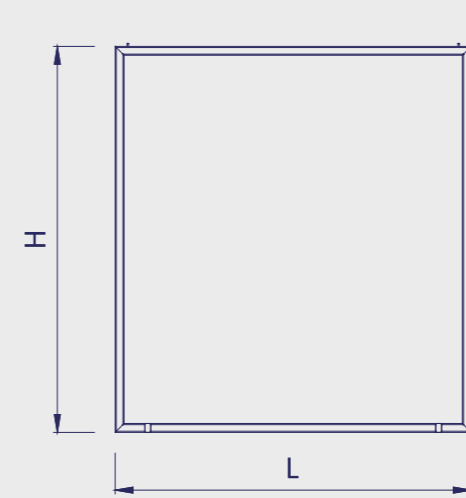

TEXTILE &
SHOES
TEKSTİL &
AYAKKABI



TEXTILE &
SHOES
TEKSTİL &
AYAKKABI

HERMOD MULTILAYERED TABLE
HERMOD KATLI ORTA SEHPA

Code / Kod	P	H	L	Description / Açıklama
8D00000050U	1450	1450	1220	

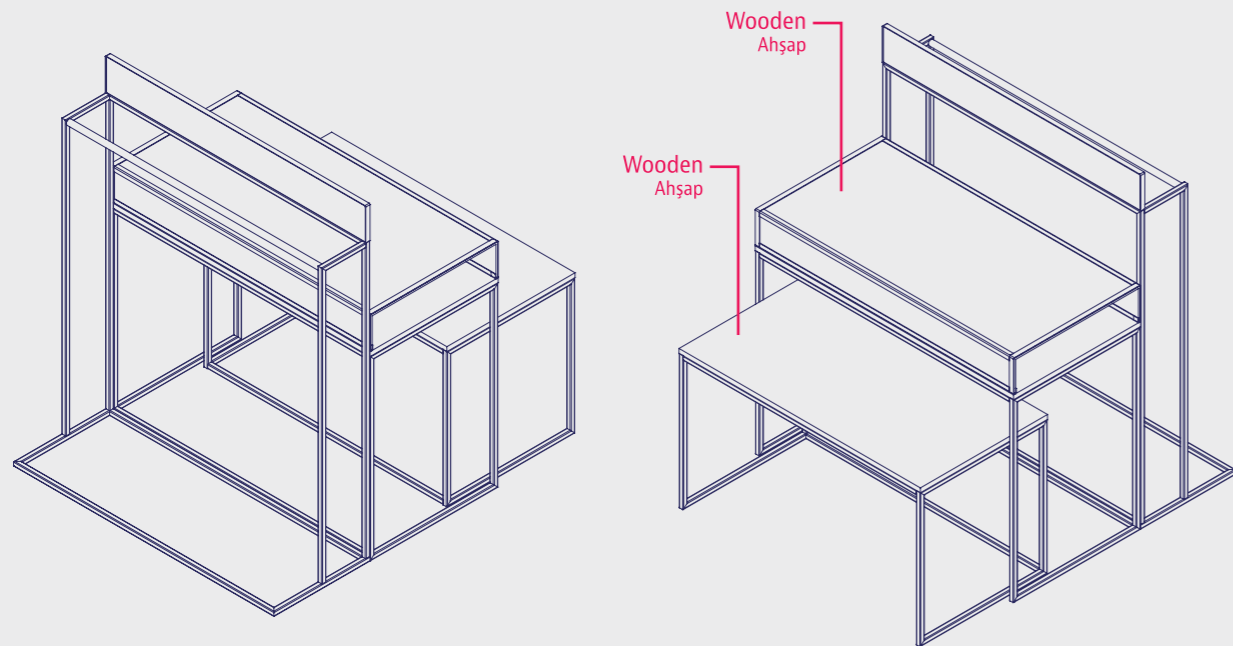
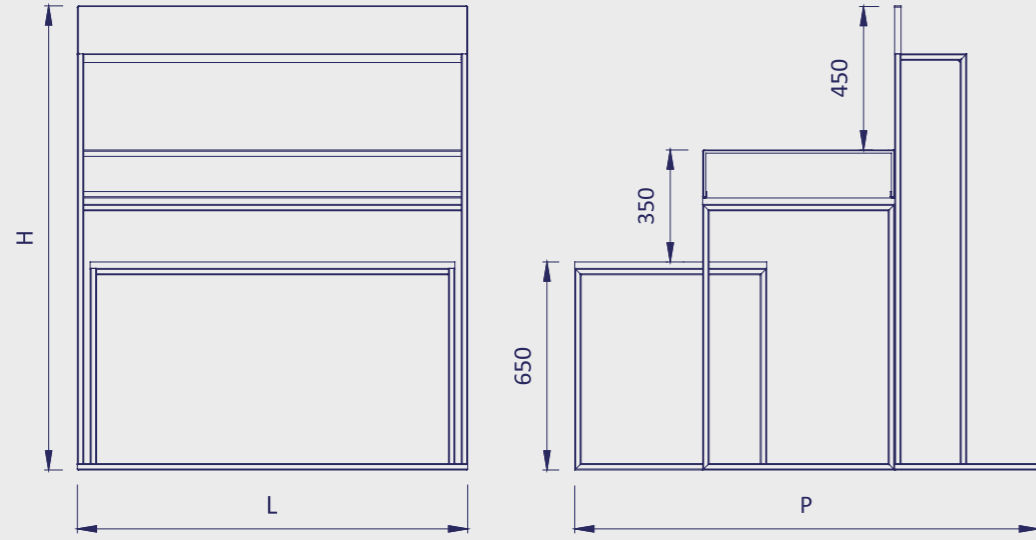

TEXTILE &
SHOES
TEKSTİL &
AYAKKABI

SKADI KİOKS
SKADI KİOKS SEHPA

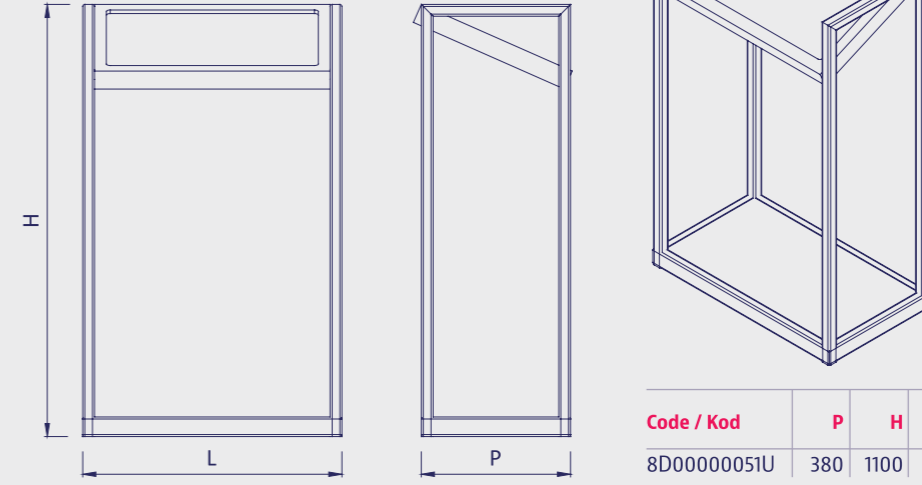

Code / Kod	P	H	L	Description / Açıklama
8D00000051U	380	1100	660	

KRATOS ACROBAT
KRATOS AKROBAT

Code / Kod	P	H	L	Description / Açıklama
8D00000031U	462	1255	1145	Akrobatın boyu isteğe göre değişebilmektedir.

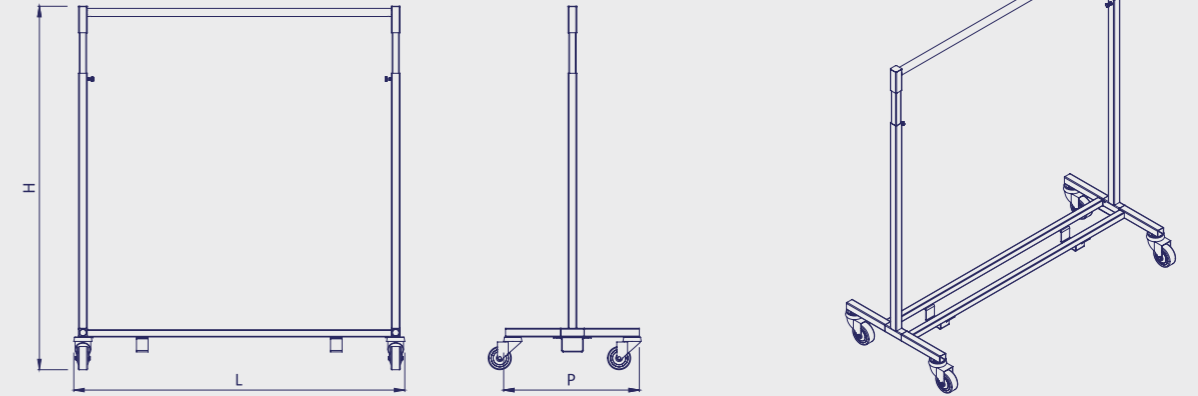

KİBELE ACROBAT
KİBELE 1 KOLLU
AKROBAT

Code / Kod	P	H	L	Description / Açıklama
8D00000052U	1458	1790	1458	

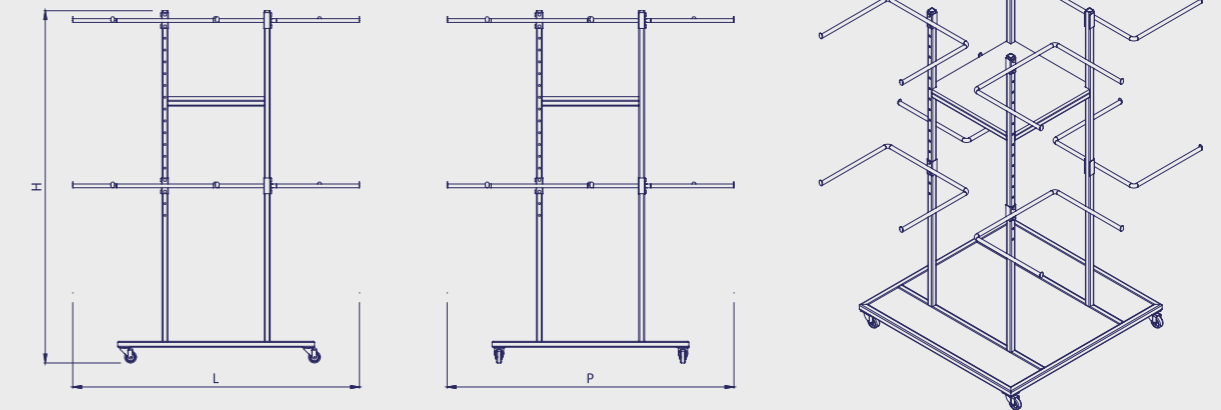

D

09

**GLASSWARE &
HOME TEXTILE**

**ZÜCCACIYE &
EV TEKSTİLİ**

ATLAS MULTILAYERED TABLE
ATLAS KATLI ORTA SEHPA

Code / Kod	P	H	L	Description / Açıklama
8D00000019U	1300	900	1300	

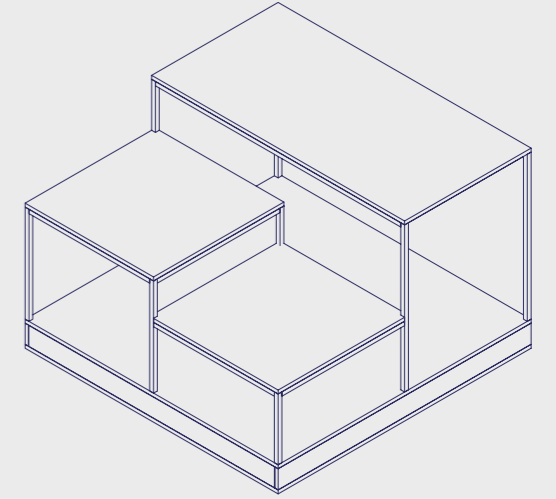
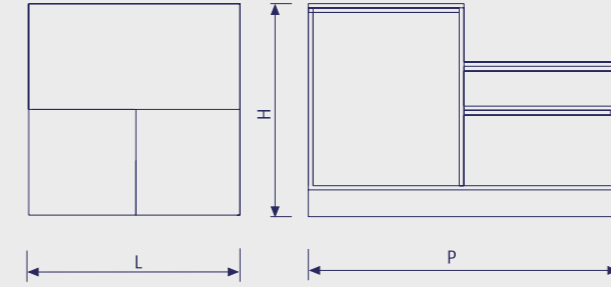

**GLASSWARE &
HOME TEXTILE**
ZÜCCACIYE &
EV TEKSTİLİ

MITIS MULTI LAYERED TABLE
MİTİS KATLI ORTA SEHPA

Code / Kod	P	H	L	Description / Açıklama
8D00000020U	665	800	1330	

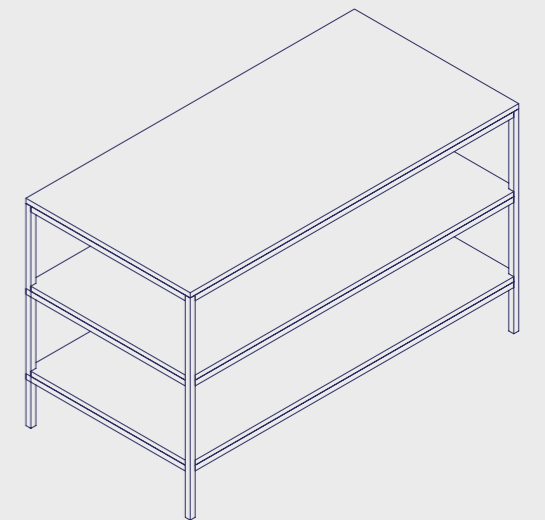
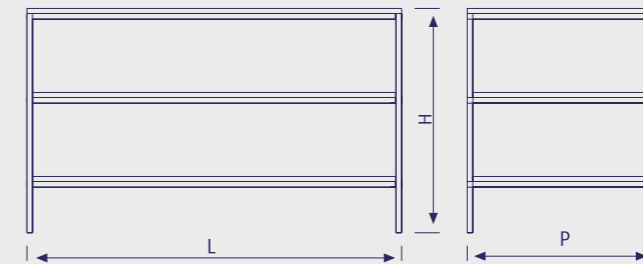



GLASSWARE &
HOME TEXTILE
ZÜCCACIYE &
EV TEKSTİLİ

PALLAS MULTI LAYERED TABLE
PALLAS KATLI ORTA SEHPA

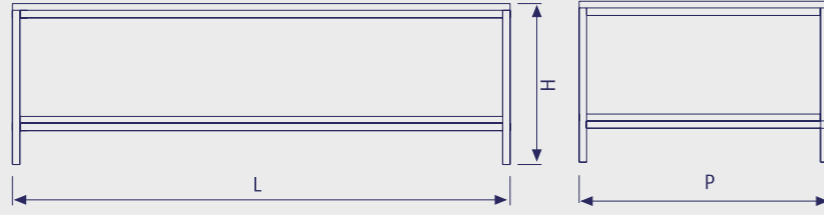

Code / Kod	P	H	L	Description / Açıklama
8D00000021U	665	450	1330	

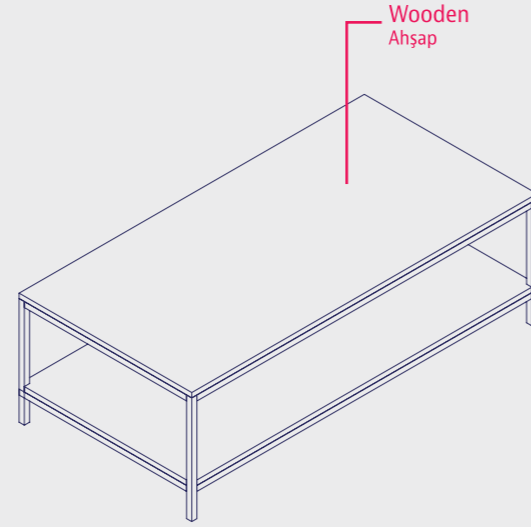

AHURA MULTILAYERED TABLE
AHURA KATLI ORTA SEHPA

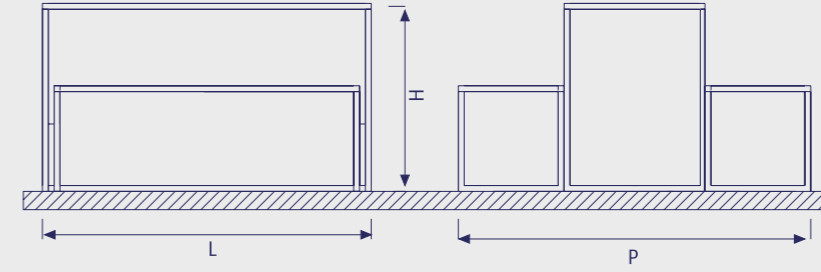

Code / Kod	P	H	L	Description / Açıklama
8D00000041U	1500	800	1400	With wooden shelf / Ahşap Rafı Metal legs can be painted - chrome - stainless steel Metal ayaklar boyalı - nikel - paslanmaz olabilir

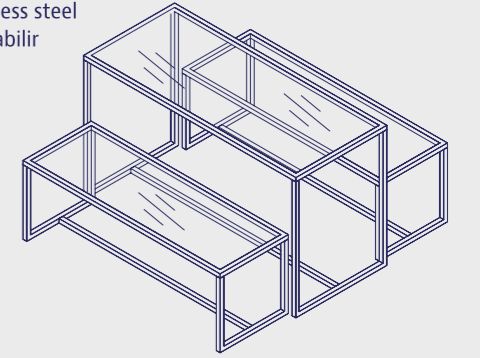

GLASSWARE &
HOME TEXTILE
ZÜCCACIYE &
EV TEKSTİLİ

PERSES MULTILAYERED TABLE
PERSES KATLI ORTA SEHPA

Code / Kod	P	H	L	Description / Açıklama
8D00000022U	1050	800	1400	With wooden shelf / Ahşap Rafı Metal legs can be painted - chrome - stainless steel Metal ayaklar boyalı - nikel - paslanmaz olabilir

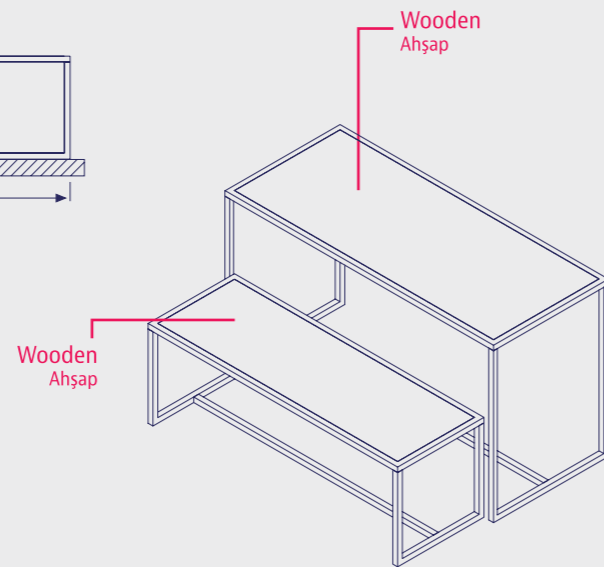
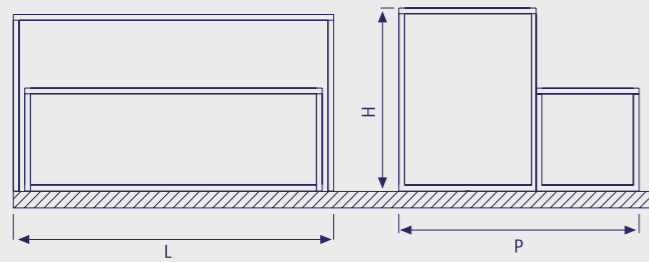

MAZDA MULTILAYERED TABLE
MAZDA KATLI ORTA SEHPA

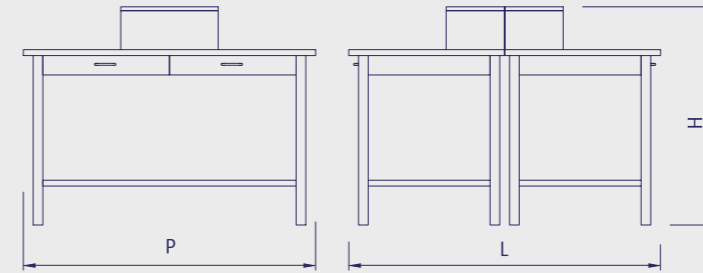

Code / Kod	P	H	L	Description / Açıklama
8D00000042U	1500	1120	1600	

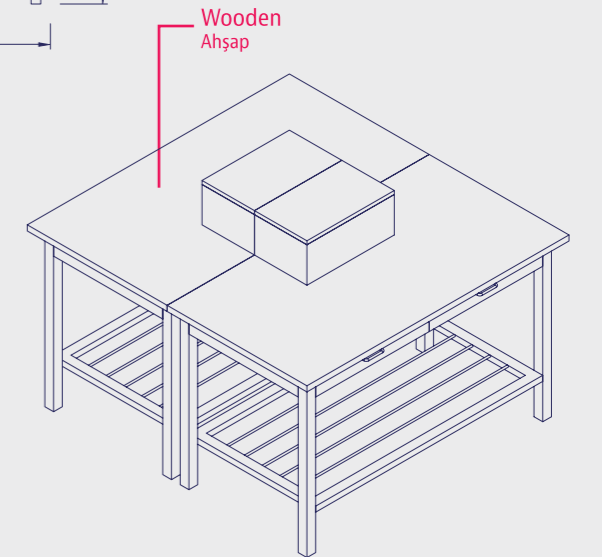



GLASSWARE &
HOME TEXTILE
ZÜCCACIYE &
EV TEKSTİLİ

DAMASK WOODEN WALL UNIT DAMASK AHŞAP DUVAR REYONU

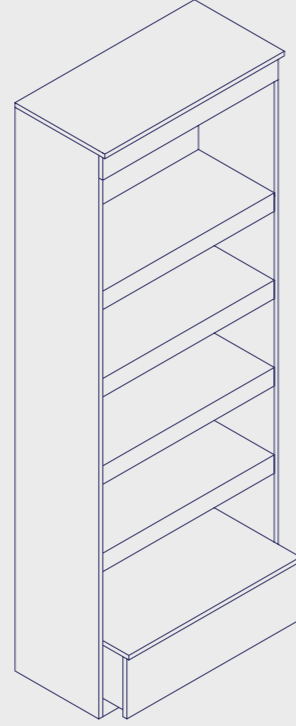
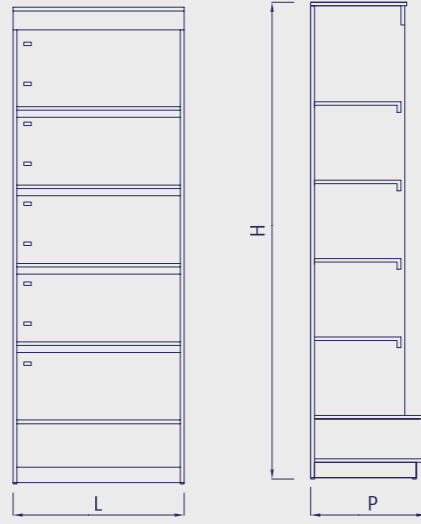

Code / Kod	P	H	L	Description / Açıklama
23A0000001U	600	2270	700	
23A0000008U	600	2270	900	

JERSEY WOODEN WALL UNIT JERSEY AHŞAP DUVAR REYONU

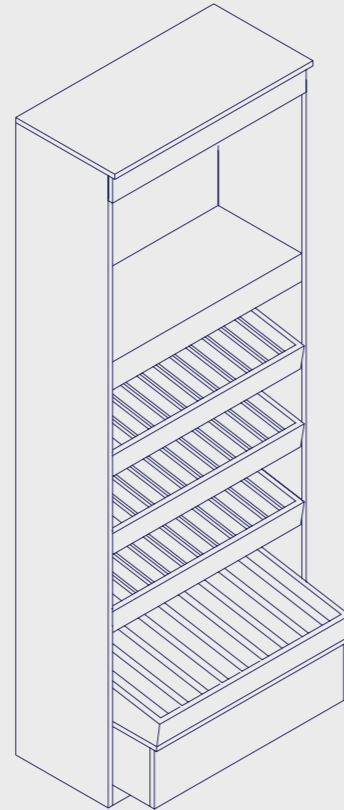
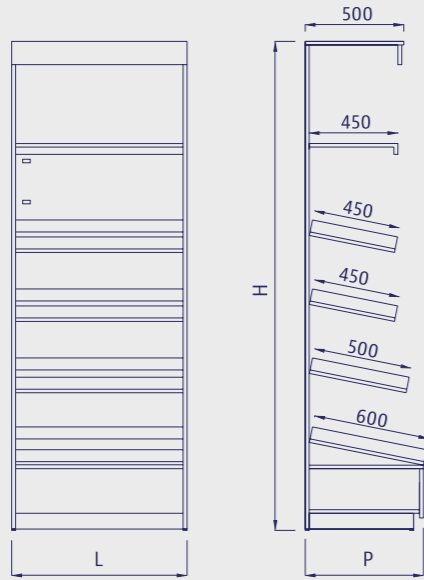

Code / Kod	P	H	L	Description / Açıklama
23A0000002U	600	2270	700	
23A0000009U	600	2270	900	

MULTILAYERED TABLE KATLI SEHPA

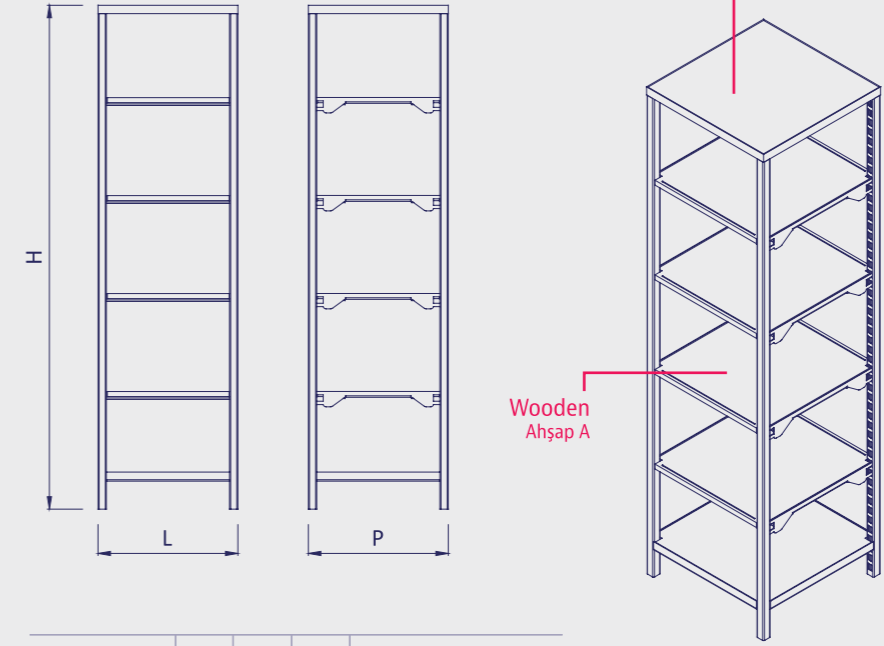

Code / Kod	P	H	L	Description / Açıklama
8F00000003U	500	1800	1500	

METIS MULTILAYERED TABLE DOUBLE METİS İKİLİ ORTA SEHPA

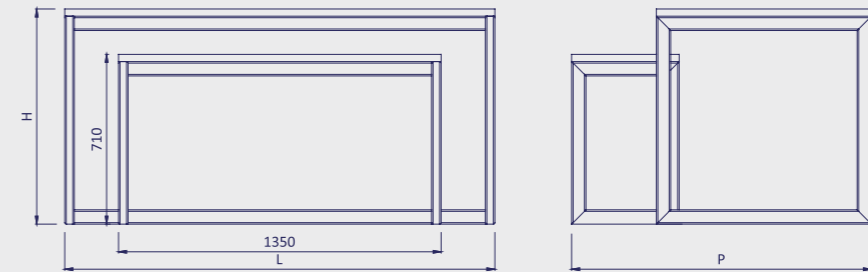

Code / Kod	P	H	L	Description / Açıklama
8D000000043U	900	900	1800	



GLASSWARE &
HOME TEXTILE
ZÜCCACIYE &
EV TEKSTİLİ



GLASSWARE &
HOME TEXTILE
ZÜCCACIYE &
EV TEKSTİLİ

VELVET WOODEN WALL UNIT VELVET AĖŞAP DUVAR REYONU

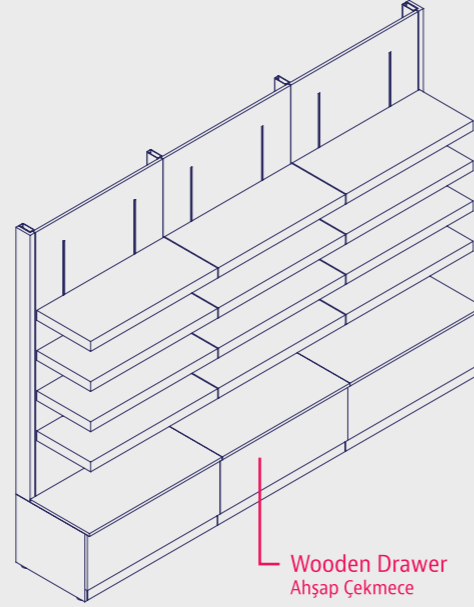
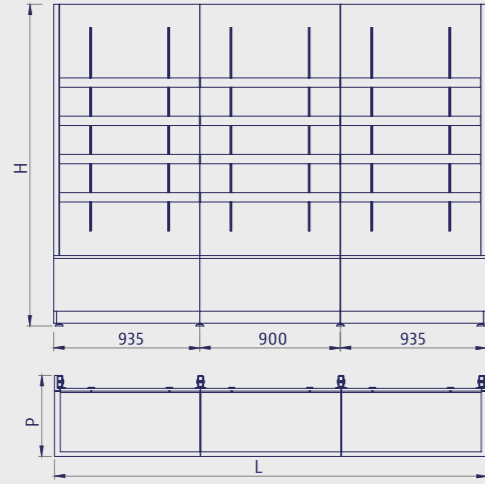

Code / Kod	P	H	L	Description / Açıklama
23A0000003U	518	2270	2270	

SATIN WOODEN WALL UNIT SATIN AĖŞAP DUVAR REYONU

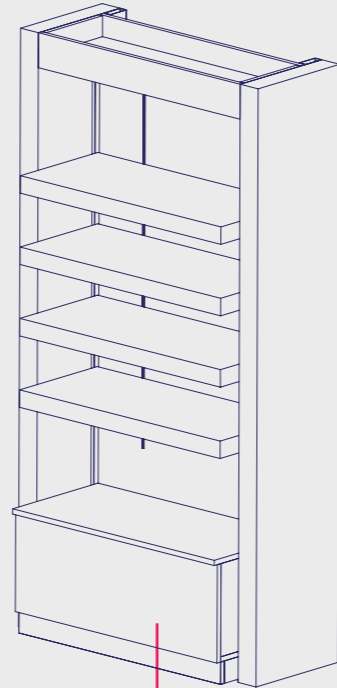
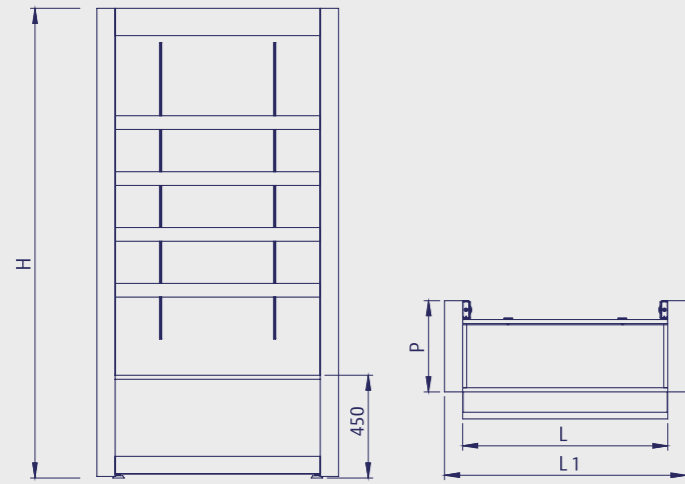

Code / Kod	P	H	L	L1	Description / Açıklama
23A0000004U	518	2270	900	1060	

PANNE WALL UNIT PANNE DUVAR REYONU

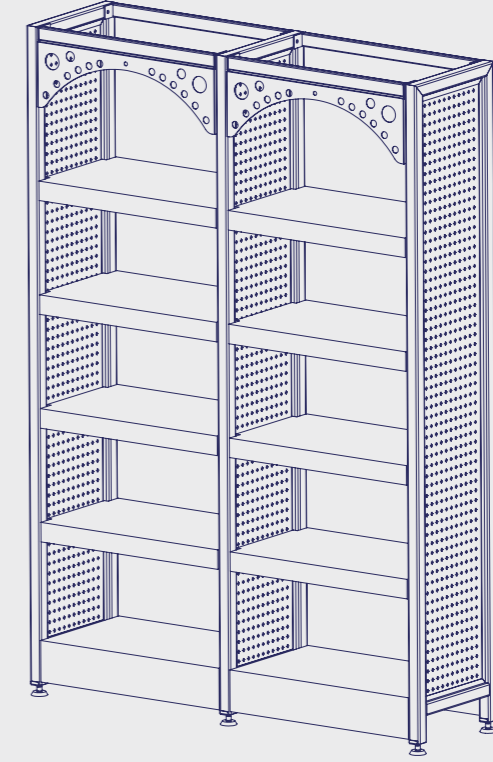
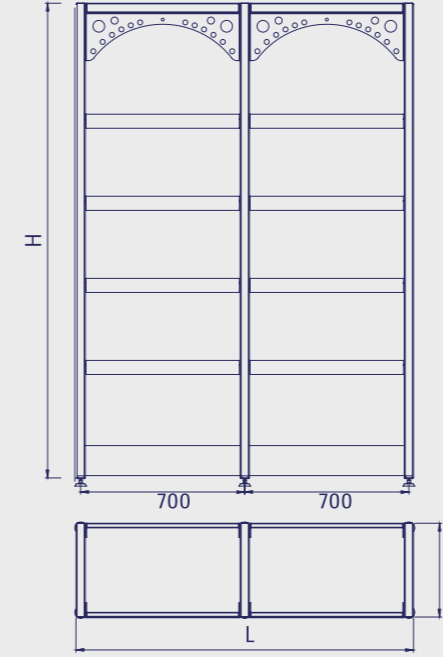

Code / Kod	P	H	L	Description / Açıklama
23A0000005U	400	2025	1440	

PANNE WALL UNIT PANNE DUVAR REYONU

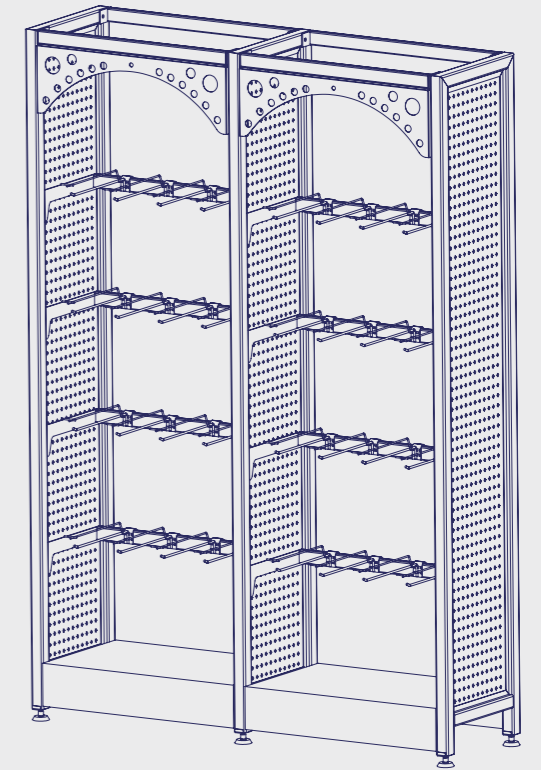
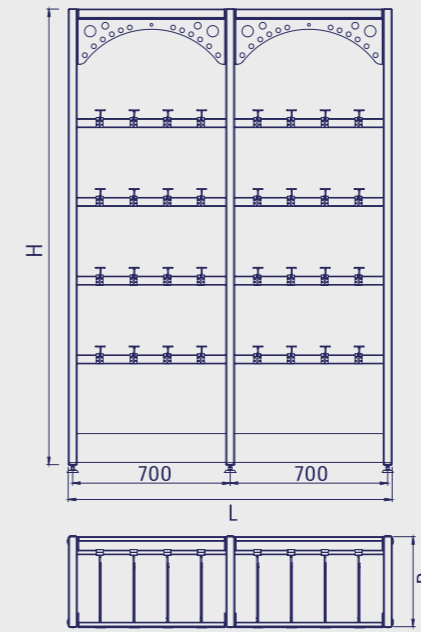

Code / Kod	P	H	L	Description / Açıklama
23A0000006U	400	2025	1440	



GLASSWARE &
HOME TEXTILE
ZÜCCACIYE &
EV TEKSTİLİ



GLASSWARE &
HOME TEXTILE
ZÜCCACIYE &
EV TEKSTİLİ

MINEVRA MULTILAYERED TABLE
MİNEVRA KATLI ORTA SEHPA

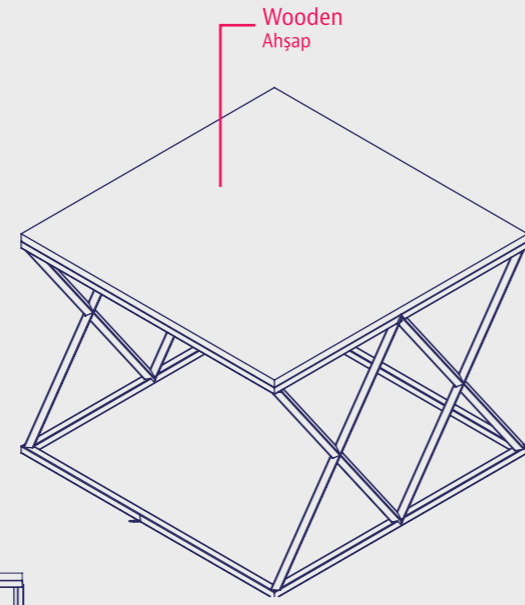

Code / Kod	P	H	L	Description / Açıklama
8D00000044U	1200	900	1200	

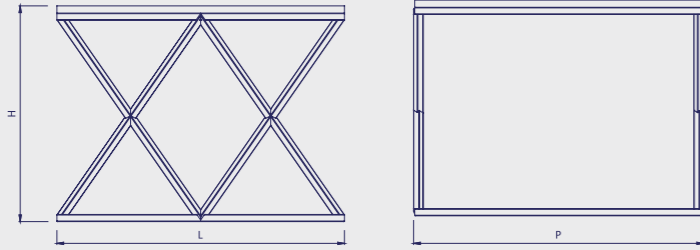

CHINO MULTILAYERED TABLE
CHİNO KATLI ORTA SEHPA

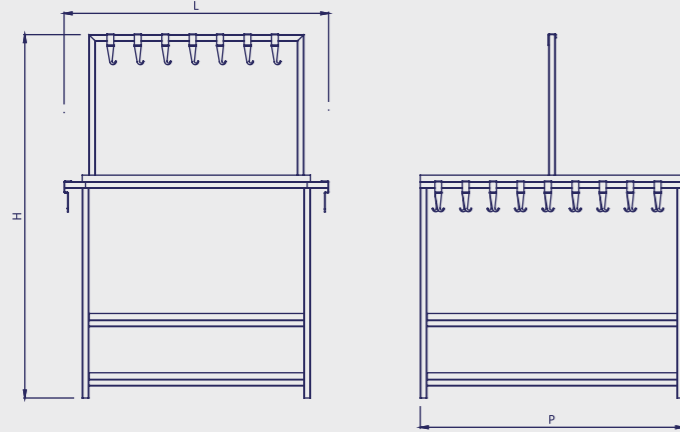

Code / Kod	P	H	L	Description / Açıklama
23A0000007U	1200	1655	1200	



GLASSWARE &
HOME TEXTILE
ZÜCCACIYE &
EV TEKSTİLİ

DEMETER MULTILAYERED STAND
DEMETER KATLI ORTA STAND

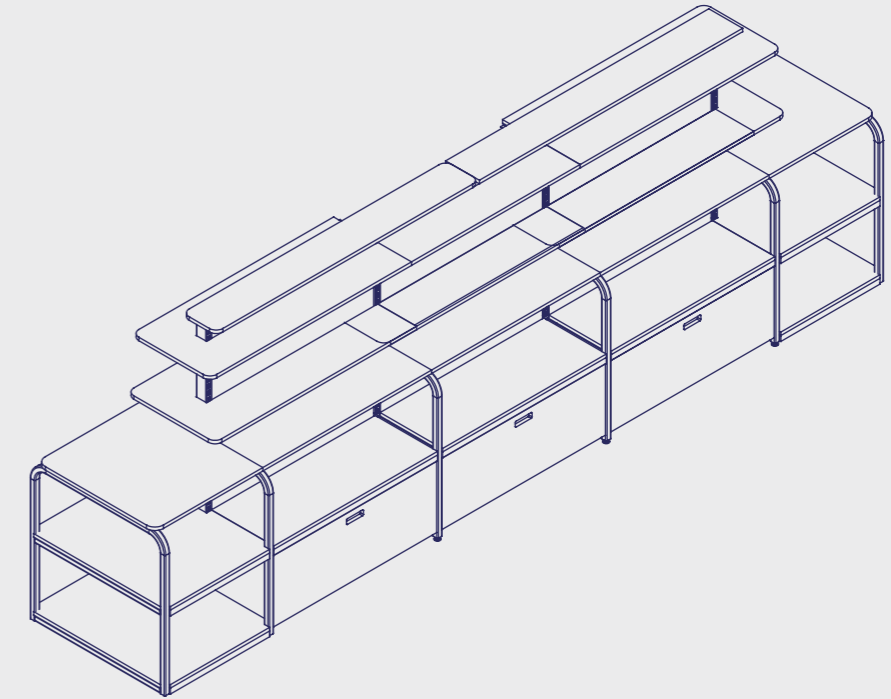
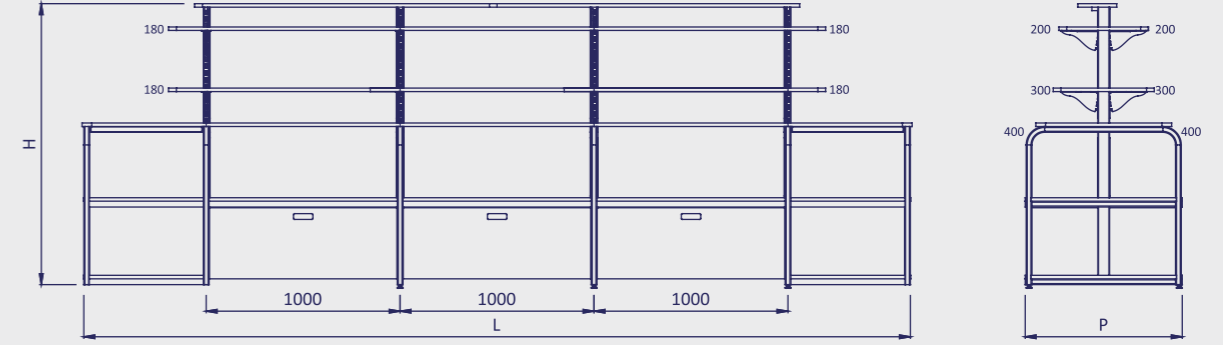

Code / Kod	P	H	L	Description / Açıklama
8D00000045U	800	1450	4262	L uzunluğu projeye göre değişiklik göstermektedir.

GÖKÇELİK